

ASUS[®] Terminator P4

Barebone System

User's Guide



Disclaimer/Copyrights

Copyright © 2002 ASUSTeK COMPUTER INC. All Rights Reserved.

No part of this manual, including the products and software described in it, may be reproduced, transmitted, transcribed, stored in a retrieval system, or translated into any language in any form or by any means, except documentation kept by the purchaser for backup purposes, without the express written permission of ASUSTeK COMPUTER INC. ("ASUS").

Product warranty or service will not be extended if: (1) the product is repaired, modified or altered, unless such repair, modification or alteration is authorized in writing by ASUS; or (2) the serial number of the product is defaced or missing.

ASUS PROVIDES THIS MANUAL "AS IS" WITHOUT WARRANTY OF ANY KIND, EITHER EXPRESS OR IMPLIED, INCLUDING BUT NOT LIMITED TO THE IMPLIED WARRANTIES OR CONDITIONS OF MERCHANTABILITY OR FITNESS FOR A PARTICULAR PURPOSE. IN NO EVENT SHALL ASUS, ITS DIRECTORS, OFFICERS, EMPLOYEES OR AGENTS BE LIABLE FOR ANY INDIRECT, SPECIAL, INCIDENTAL, OR CONSEQUENTIAL DAMAGES (INCLUDING DAMAGES FOR LOSS OF PROFITS, LOSS OF BUSINESS, LOSS OF USE OR DATA, INTERRUPTION OF BUSINESS AND THE LIKE), EVEN IF ASUS HAS BEEN ADVISED OF THE POSSIBILITY OF SUCH DAMAGES ARISING FROM ANY DEFECT OR ERROR IN THIS MANUAL OR PRODUCT.

SPECIFICATIONS AND INFORMATION CONTAINED IN THIS MANUAL ARE FURNISHED FOR INFORMATIONAL USE ONLY, AND ARE SUBJECT TO CHANGE AT ANY TIME WITHOUT NOTICE, AND SHOULD NOT BE CONSTRUED AS A COMMITMENT BY ASUS. ASUS ASSUMES NO RESPONSIBILITY OR LIABILITY FOR ANY ERRORS OR INACCURACIES THAT MAY APPEAR IN THIS MANUAL, INCLUDING THE PRODUCTS AND SOFTWARE DESCRIBED IN IT.

Products and corporate names appearing in this manual may or may not be registered trademarks or copyrights of their respective companies, and are used only for identification or explanation and to the owners' benefit, without intent to infringe.

Product Name:	ASUS Terminator P4 Barebone System
Manual Revision:	1.00 E947
Release Date:	February 2002

Table of contents

Disclaimer/Copyrights	2
FCC/CDC statements	5
Safety information	6
About this guide	7
ASUS contact information	9
System package contents	10
Chapter 1: System Introduction	11
1.1 Front Panel Features	12
1.2 Rear Panel Features	13
1.3 Internal Features	14
Chapter 2: Basic Installation	15
2.1 Remove the cover	16
2.2 Detach the drive frame	17
2.3 Install a CPU	19
2.4 Install the CPU heatsink and fan	21
2.5 Install system memory	23
2.6 Install a hard disk drive	24
2.7 Install a CD-ROM drive	26
2.8 Install a PCI expansion card	28
2.9 Re-connect cables	29
2.9.1 Front panel	29
2.9.2 UAEX extension module	29
2.9.3 Motherboard	30
2.10 Replace the cover	31
2.11 Connect External Devices	33
2.12 Power Supply Specifications	34
2.12.1 Input Characteristics	34
2.12.2 Output Characteristics	34
2.12.3 Over-Voltage Protection (OVP)	34
Chapter 3: Motherboard Information	35
3.1 Introduction	36
3.2 Motherboard components	36
3.3 Motherboard layout	39

3.4	Central Processing Unit (CPU)	40
3.5	System memory	41
3.5.1	Memory configurations	41
3.6	Expansion slots	42
3.6.1	Configuring an expansion card	42
3.6.2	Standard Interrupt Assignments	42
3.6.3	IRQ assignments for this motherboard	42
3.7	Jumpers	43
3.8	Connectors	45
Chapter 4: BIOS Information		55
4.1	Managing and updating the BIOS	56
4.1.1	Using the computer system for the first time	56
4.1.2	Updating BIOS procedures	58
4.2	BIOS Setup program	60
4.2.1	BIOS menu bar	61
4.2.2	Legend bar	61
4.3	Main Menu	63
4.3.1	Primary and Secondary Master/Slave	64
4.3.2	Keyboard Features	68
4.4	Advanced Menu	70
4.4.1	Chip Configuration	72
4.4.2	I/O Device Configuration	74
4.4.3	PCI Configuration	76
4.5	Power Menu	79
4.5.1	Power Up Control	81
4.5.2	Hardware Monitor	83
4.6	Boot Menu	84
4.7	Exit Menu	86
Chapter 5: Starting up		89
5.1	Install an operating system	90
5.2	Support CD information	90
5.2.1	Running the support CD	90
5.2.2	Installation menus	91
5.2.3	Software and drivers description	92
5.3	Software information	94
5.3.1	ASUS Update	94
5.3.2	ASUS PC Probe	96

FCC/CDC statements

Federal Communications Commission Statement

This device complies with FCC Rules Part 15. Operation is subject to the following two conditions:

- This device may not cause harmful interference, and
- This device must accept any interference received including interference that may cause undesired operation.

This equipment has been tested and found to comply with the limits for a Class B digital device, pursuant to Part 15 of the FCC Rules. These limits are designed to provide reasonable protection against harmful interference in a residential installation. This equipment generates, uses and can radiate radio frequency energy and, if not installed and used in accordance with manufacturer's instructions, may cause harmful interference to radio communications. However, there is no guarantee that interference will not occur in a particular installation. If this equipment does cause harmful interference to radio or television reception, which can be determined by turning the equipment off and on, the user is encouraged to try to correct the interference by one or more of the following measures:

- Reorient or relocate the receiving antenna.
- Increase the separation between the equipment and receiver.
- Connect the equipment to an outlet on a circuit different from that to which the receiver is connected.
- Consult the dealer or an experienced radio/TV technician for help.

WARNING!

The use of shielded cables for connection of the monitor to the graphics card is required to assure compliance with FCC regulations. Changes or modifications to this unit not expressly approved by the party responsible for compliance could void the user's authority to operate this equipment.

Canadian Department of Communications Statement

This digital apparatus does not exceed the Class B limits for radio noise emissions from digital apparatus set out in the Radio Interference Regulations of the Canadian Department of Communications.

This class B digital apparatus complies with Canadian ICES-003.

Safety information

Electrical safety

- To prevent electrical shock hazard, disconnect the power cable from the electrical outlet before relocating the system.
- When adding or removing devices to or from the system, ensure that the power cables for the devices are unplugged before the signal cables are connected.
- Before connecting or removing cables from the motherboard, ensure that all power cables are unplugged.
- Seek professional assistance before using an adapter or extension cord. These devices could interrupt the grounding circuit.
- Make sure that your power supply is set to the correct voltage in your area. If you are not sure about the voltage of the electrical outlet you are using, contact your local power company.
- If the power supply is broken, do not try to fix it by yourself. Contact a qualified service technician or your retailer.

Operation safety

- Before installing devices into the system, carefully read all the documentation that came with the package.
- Before using the product, make sure all cables are correctly connected and the power cables are not damaged. If you detect any damage, contact your dealer immediately.
- To avoid short circuits, keep paper clips, screws, and staples away from connectors, slots, sockets and circuitry.
- Avoid dust, humidity, and temperature extremes. Do not place the product in any area where it may become wet.
- Place the product on a stable surface.
- If you encounter technical problems with the product, contact a qualified service technician or your retailer.

About this guide

Audience

This guide provides general information and installation instructions about the ASUS Terminator P4 Barebone System. This guide is intended for experienced users and integrators with hardware knowledge of personal computers.

How this guide is organized

This document contains the following parts:

- 1. Chapter 1: System Introduction**
This chapter gives a general description of the ASUS Terminator P4 barebone system. It includes introduction on the front and rear panel features, and the internal features.
- 2. Chapter 2: Basic Installation**
This chapter tells how to install components into the barebone system through illustrated step-by-step instructions.
- 3. Chapter 3: Motherboard Information**
This chapter gives information about the P4SC motherboard that came with the system. This chapter includes the motherboard layout, jumper settings, and connector locations. It also includes information on the USB/audio board located on the front panel.
- 4. Chapter 4: BIOS information**
This chapter tells how to change system settings through the BIOS Setup menus. It includes detailed descriptions of the BIOS parameters.
- 5. Chapter 5: Starting up**
This chapter helps you power up your system and install drivers and utilities that came with the support CD.

About this guide

Conventions used in this guide

WARNING!	Information to prevent injury to yourself when trying to complete a task.
CAUTION!	Information to prevent damage to the components when trying to complete a task.
IMPORTANT	Information that you MUST follow to complete a task.
NOTE	Tips and additional information to aid in completing a task.

Where to find more information

Refer to the following sources for additional information and for product and software updates.

1. **ASUS Websites**

The ASUS websites worldwide provide updated information on ASUS hardware and software products. The ASUS websites are listed on page 9.

2. **Optional Documentation**

Your product package may include optional documentation, such as warranty flyers, that may have been added by your dealer. These documents are not part of the standard package.

ASUS contact information

ASUSTeK COMPUTER INC. (Asia-Pacific)

Address: 150 Li-Te Road, Peitou, Taipei, Taiwan 112
General Tel: +886-2-2894-3447
General Fax: +886-2-2894-3449
General Email: info@asus.com.tw

Technical Support

MB/Others (Tel): +886-2-2890-7121 (English)
Notebook (Tel): +886-2-2890-7122 (English)
Desktop/Server (Tel): +886-2-2890-7123 (English)
Support Fax: +886-2-2890-7698
Support Email: tsd@asus.com.tw
Web Site: www.asus.com.tw
Newsgroup: cscnews.asus.com.tw

ASUS COMPUTER INTERNATIONAL (America)

Address: 6737 Mowry Avenue, Mowry Business Center,
Building 2, Newark, CA 94560, USA
General Fax: +1-510-608-4555
General Email: tmd1@asus.com

Technical Support

Support Fax: +1-510-608-4555
Notebook (Tel): 1-877-918-ASUS (2787)
Web Site: www.asus.com
Support Email: tsd@asus.com

ASUS COMPUTER GmbH (Europe)

Address: Harkortstr. 25, 40880 Ratingen, BRD, Germany
General Fax: +49-2102-442066
General Email: sales@asuscom.de (for marketing requests only)

Technical Support

Support Hotline: MB/Others: +49-2102-9599-0
Notebook (Tel): +49-2102-9599-10
Support Fax: +49-2102-9599-11
Support (Email): www.asuscom.de/de/support (for online support)
Web Site: www.asuscom.de

System package contents

Check your ASUS Terminator P4 package for the following items:

1. Barebone system
2. Motherboard
3. Switching power supply
4. 1.44MB floppy disk drive
5. CD-ROM Drive (optional)
6. 56K PCI modem card (optional)
7. Support CD
8. User's guide

NOTE

Optional items may not be present in your package.

If any of the above items is damaged or missing, contact your dealer immediately.

IMPORTANT

If you are assembling the system by yourself, make sure to prepare all the components before starting. It saves you a lot of time not having to hunt down components when you need them.

Chapter 1

This chapter gives a general description of the ASUS Terminator P4 barebone system. It includes introduction on the front and rear panel features, and the internal features.

System Introduction

1.1 Front Panel Features

The ASUS Terminator P4 barebone system is composed of the ASUS P4SC motherboard, a power supply, and a floppy disk drive in the ASUS TriOptix form factor chassis. The chassis front bezel may vary as shown.

NOTE

The CD-ROM drive and modem card are optional items.

Chassis 1



Chassis 2



CD-ROM Drive (optional)

Floppy Drive

Power Button

Power LED

HDD LED

Microphone Jack

Headphone Jack

USB Ports



Front Panel I/O Door

Microphone Jack

Headphone Jack

Front Panel I/O Door



USB Ports

The lower part of the front panel is a door that covers accessible I/O features including two USB ports (Ports 2&3), a headphone jack, and a microphone jack.

Open chassis 1 I/O door by pressing the dotted area of the door.

Open chassis 2 I/O door by flipping up the door.

1.2 Rear Panel Features

The rear panel of the ASUS Terminator P4 barebone system includes the standard PC99 I/O connectors for external devices, power supply socket, and optional modem connectors.

The following figure shows the rear panel features.

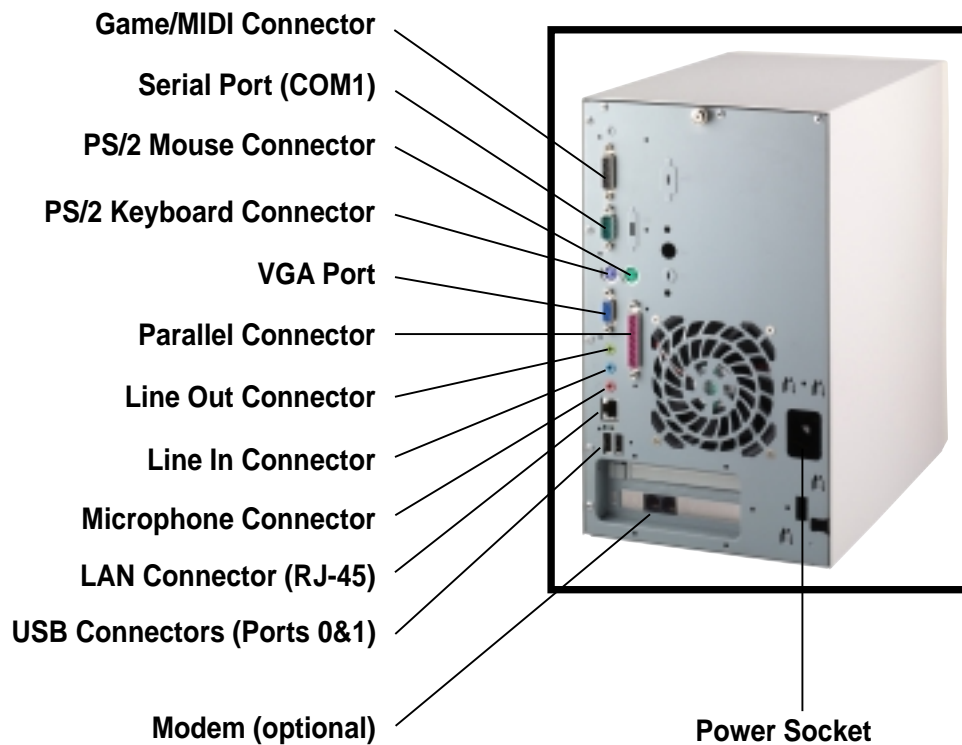

Voltage Selector

The switching power supply that came with the system has a voltage selector switch beside the power socket. Use this switch to select the appropriate voltage according to the voltage supply in your area.

If the voltage supply in your area is 100-127V, set the switch to 115V.

If the voltage supply in your area is 200-240V, set the switch to 230V.



115V/230V
Voltage Selector

CAUTION!

Setting the switch to 115V in a 230V environment will seriously damage the system!

1.3 Internal Features

The figure below shows the internal view of the system when you remove the cover and flip out the drive frame. You will see here the standard components that come already installed in the system and the places where you can install the other required components to get the system running.

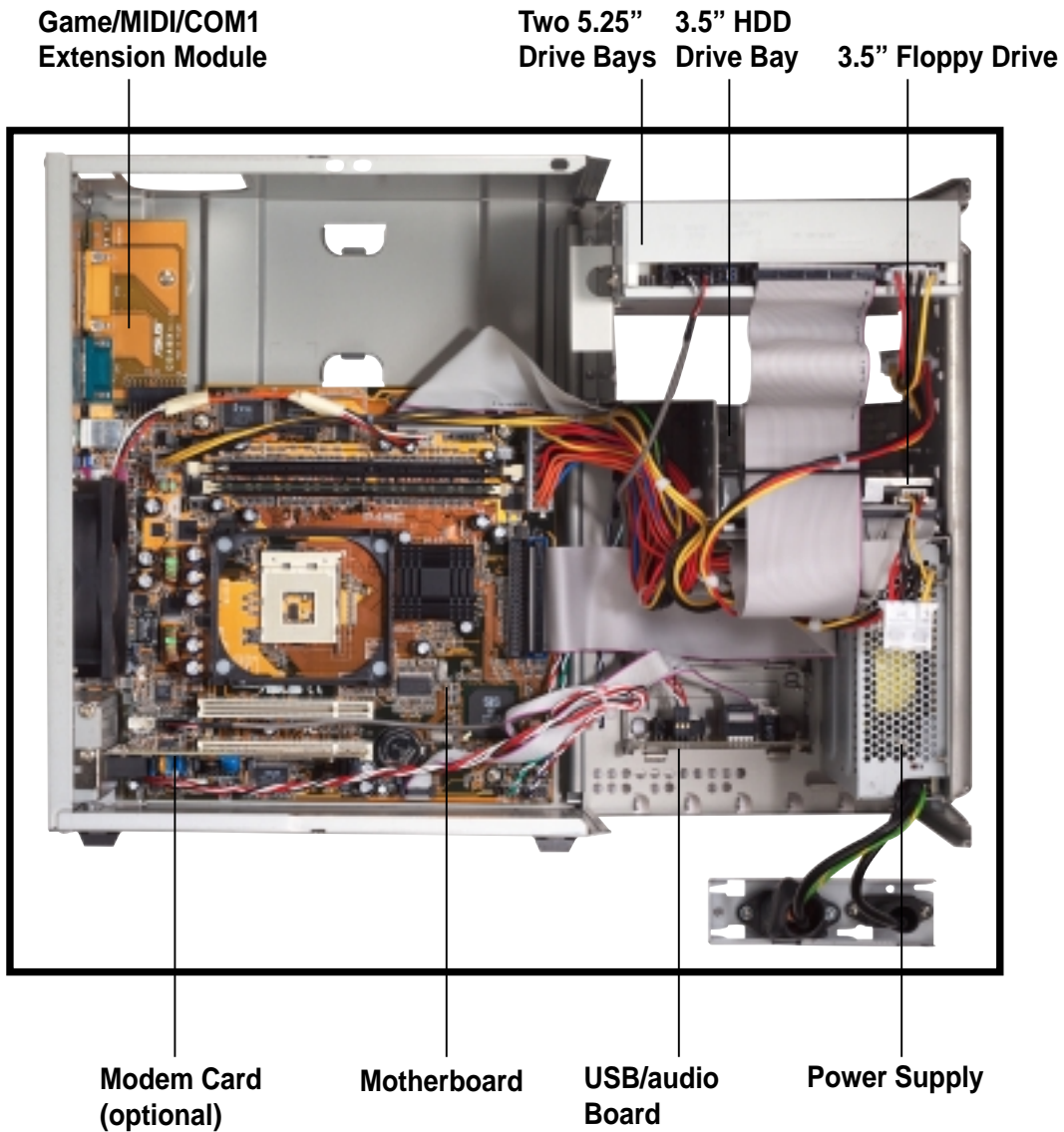

Chapter 2

This chapter tells how to install components into the barebone system through illustrated step-by-step instructions.

Basic Installation

2.1 Remove the cover

The chassis cover is secured by a thumbscrew located on the rear panel.

Follow these steps to remove the chassis cover.

1. Turn the captive thumbscrew counter-clockwise to release the cover. You don't have to remove the thumbscrew from the chassis.

Thumbscrew



2. Place your hands on both corners of the front panel, just beside the CD-ROM frame. Push on the CD-ROM area with your thumbs until the cover tilts forward.



TIP

Another way to release the cover is to place your hands underneath the front panel edge, then push the inner chassis with your thumbs while pulling the panel with your other fingers.

3. While supporting the front panel with one hand, place your other hand on the top rear edge of the cover and carefully lift the cover from the chassis.



2.2 Detach the drive frame

Follow these steps to detach the drive frame.

1. Place the chassis on a flat surface and turn it on its side.



2. The power socket and voltage selector switch are attached to a metal module secured to the rear panel by a screw. Remove the screw to release the power socket module.

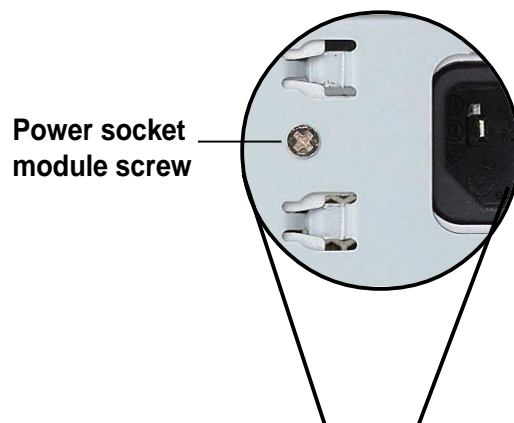

Power socket module

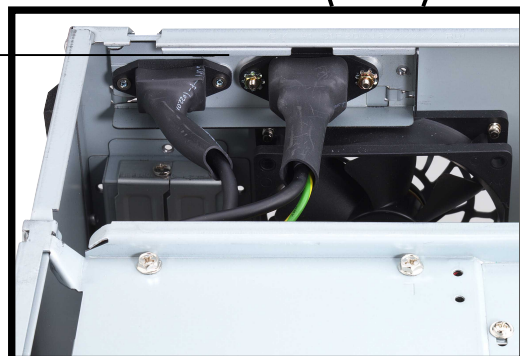

IMPORTANT

You must release the power socket module from the rear panel before detaching the drive frame to avoid breaking the power cable.

3. Place your thumb on the right edge of the power socket module, then slide the module to the right until it is completely detached from the rear panel.



4. Unlatch the drive frame by pulling it outward.

Drive frame

Swivel edge

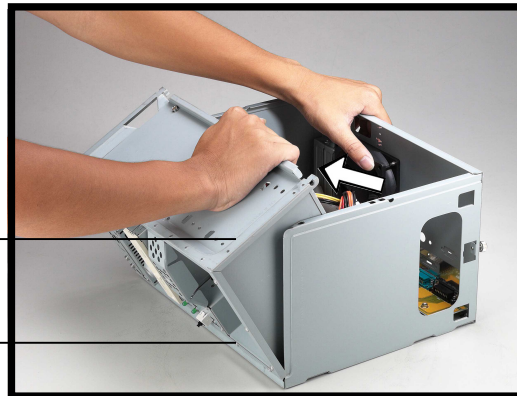

NOTE

The drive frame has a swivel (hinge-like) edge that is attached to the main chassis. It is not necessary to completely detach the drive frame from the chassis when installing components.

5. Carefully lay the drive frame alongside the main chassis frame.

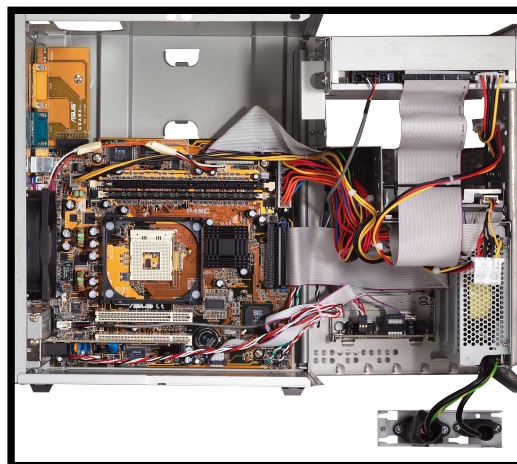

2.3 Install a CPU

The P4SC motherboard comes with a surface mount 478-pin Zero Insertion Force (ZIF) socket. This socket is specifically designed for the Intel® Pentium® 4 478/Northwood Processor.

Follow these steps to install a CPU.

1. Locate the 478-pin CPU socket on the motherboard.

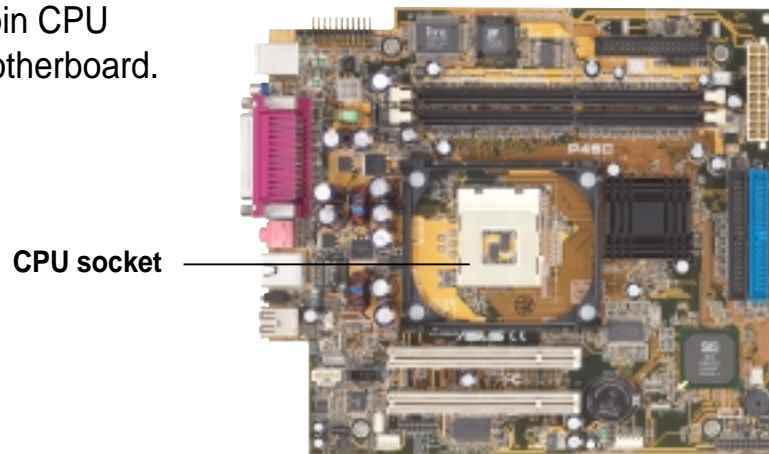

2. Unlock the socket by pressing the lever sideways then lifting it up to a 90°-100° angle.

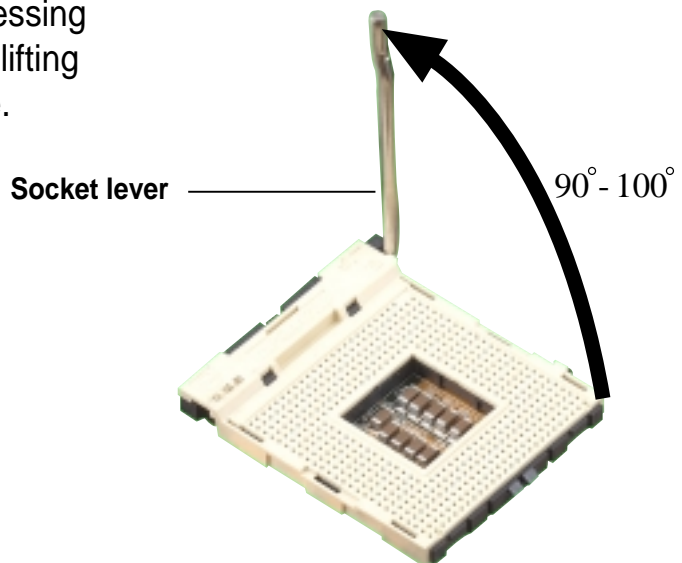

IMPORTANT

Make sure that the socket lever is lifted up to 90°-100° angle, otherwise the CPU does not fit in completely.

3. Position the CPU above the socket such that its marked corner (gold mark) matches the base of the socket lever.
4. Carefully insert the CPU into the socket until it fits in place.

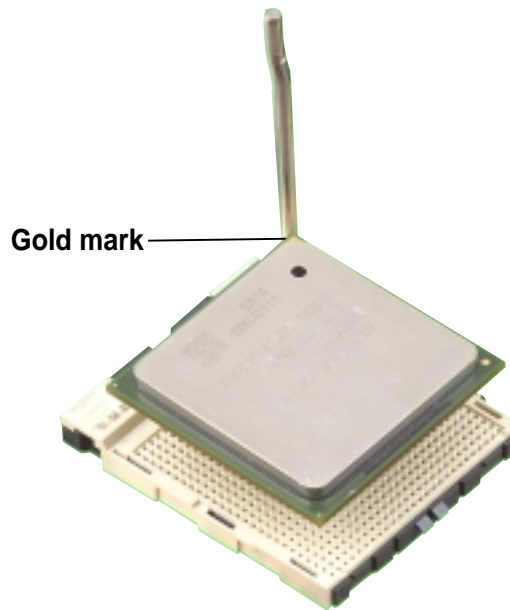

CAUTION

The CPU fits only in one correct orientation. DO NOT force the CPU into the socket to prevent bending the pins and damaging the CPU!

5. When the CPU is in place, press it firmly on the socket while you push down the socket lever to secure the CPU. The lever clicks on the side tab to indicate that it is locked.

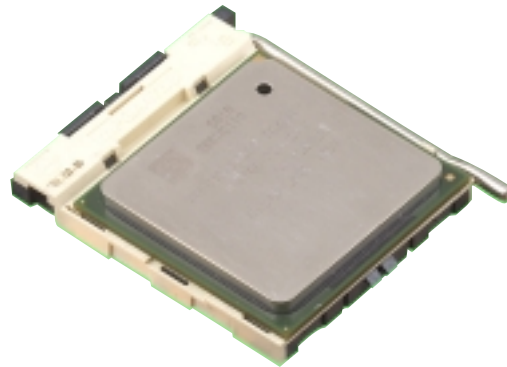

2.4 Install the CPU heatsink and fan

The Intel® Pentium® 4 478/Northwood Processor requires a specially designed heatsink and fan assembly to ensure optimum thermal condition and performance.

When you buy a boxed Intel Pentium 4 478/Northwood Processor, the package usually includes the heatsink and fan assembly.

IMPORTANT

Make sure that you use only Intel certified CPU heatsink and fan.

Follow these steps to install the CPU heatsink and fan.

1. Position the fan heatsink assembly on top of the installed CPU such that the fan cable is nearest the CPU fan connector on the motherboard (marked CPUFAN1).

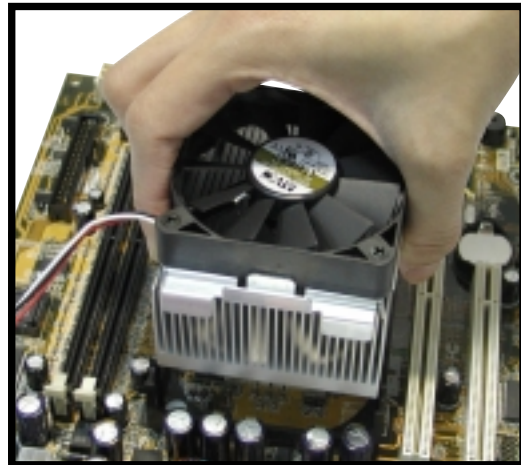

2. Align one retention bracket with the rail on the side of the heatsink. Orient the bracket such that the locking lever is on the side of the PCI slots.
3. Snap the hook of the metal retention bracket into the hole of the retention module.
4. Follow steps 2 and 3 to attach the second retention bracket.

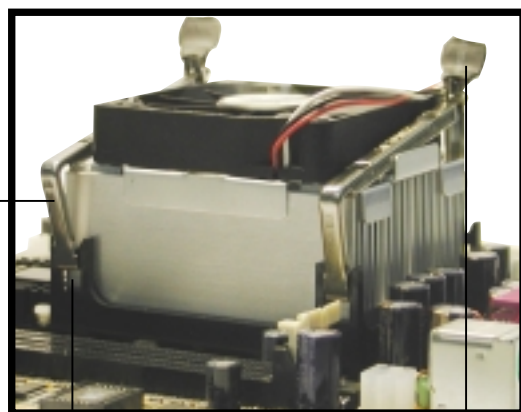

Retention bracket

Hole on the retention module

Locking lever

5. Carefully press down the locking lever on the other side of the bracket and hook its end into the hole of the retention module to secure the fan heatsink assembly in place.
6. Follow step 5 to lock the second bracket.

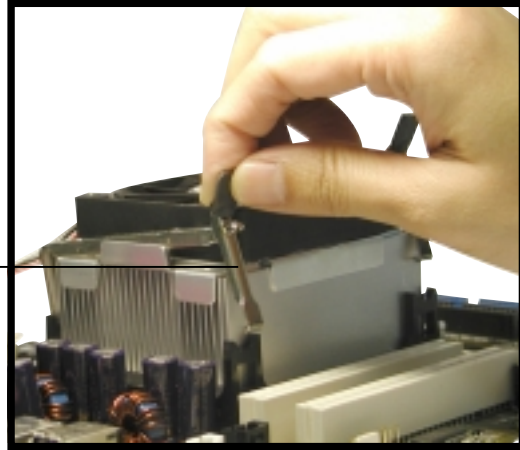

Locking lever

7. Connect the CPU fan cable from the assembly to the fan connector labeled CPUFAN1.

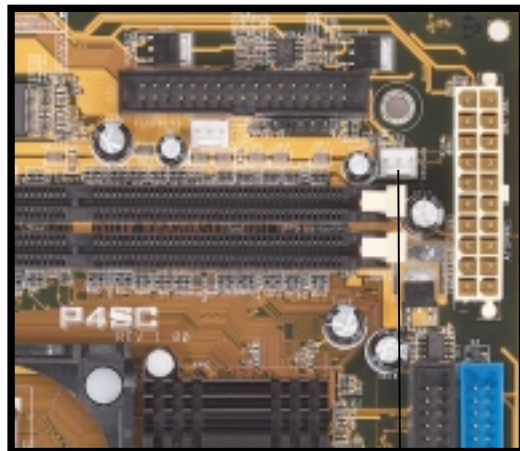

CPU fan connector (CPUFAN1)

NOTE

Your boxed Intel Pentium 4 478/Northwood Processor package may come with installation instructions for the CPU and fan heatsink assembly. If the instructions in this section do not match the documentation for the CPU or fan heatsink, follow the latter.

2.5 Install system memory

The motherboard comes with two Double Data Rate (DDR) Dual Inline Memory Module (DIMM) sockets. These sockets support up to 2GB system memory using unbuffered ECC or non-ECC PC1600/2100 DIMMs.

Follow these steps to install a DDR DIMM.

1. Locate the two DIMM sockets on the motherboard.

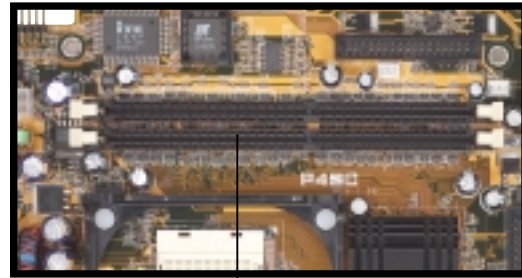

DDR DIMM sockets

2. Unlock a socket by pressing the retaining clips outward.
3. Align a DIMM on the socket such that the notch on the DIMM matches the break on the socket.

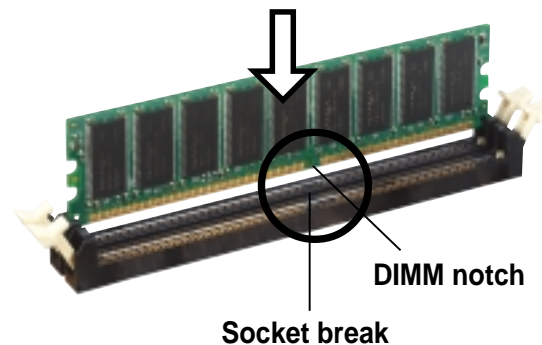

4. Firmly insert the DIMM into the socket until the retaining clips snap back in place and the DIMM is properly seated.

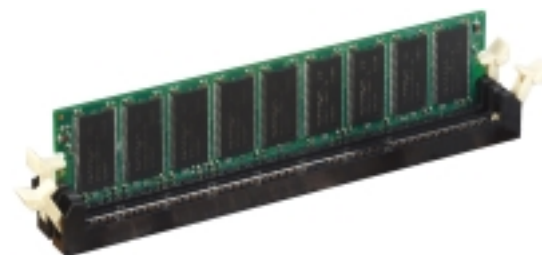

CAUTION

A DDR DIMM is keyed with a notch so that it fits in only one direction. DO NOT force a DIMM into a socket to avoid damaging the DIMM.

2.6 Install a hard disk drive

The chassis has one 3.5-inch hard disk drive (HDD) bay right under the 5.25-inch bay. The following figures show the internal and external views of the HDD bay location.

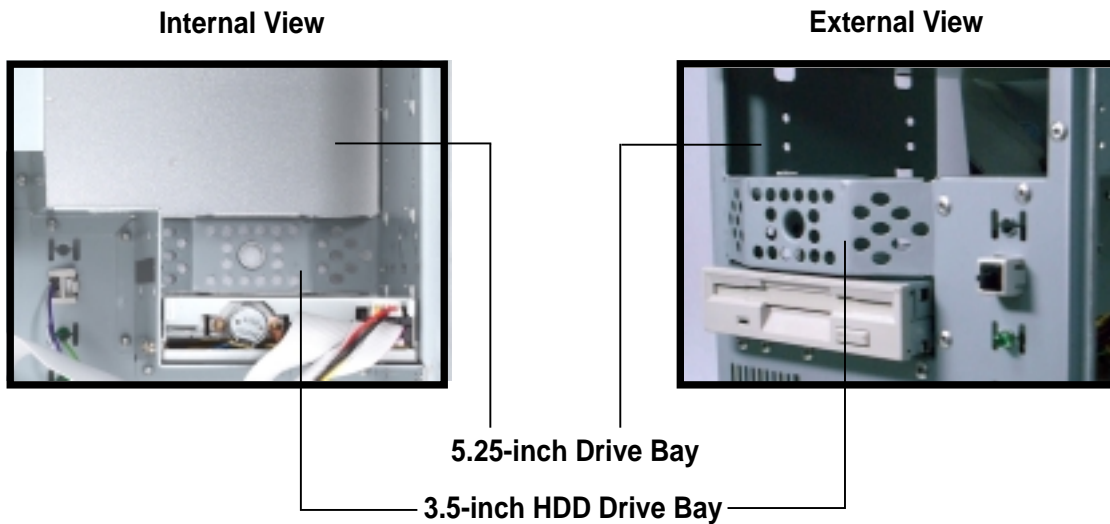

Follow these steps to install an IDE HDD.

1. Place the chassis upright.
2. With the HDD label side up, carefully insert the drive into the 3.5-inch bay.

HDD label side



3. Push the drive into the bay until its screw holes align with the holes on the bay marked HDD.
4. Secure the drive with two screws on each side of the bay.



HDD screws

5. Connect a power cable from the power supply to the power connector at the back of the HDD. Use the cable with the white connector labeled P3.
6. Connect one end of the IDE hard disk ribbon cable to the IDE interface at the back of the HDD, matching the red stripe on the cable with Pin 1 on the IDE interface.



Red Stripe to Pin 1
IDE Ribbon Cable Power Cable (P3)

7. Connect the other end of the IDE ribbon cable to the primary IDE connector (blue connector labeled IDE1) on the motherboard.

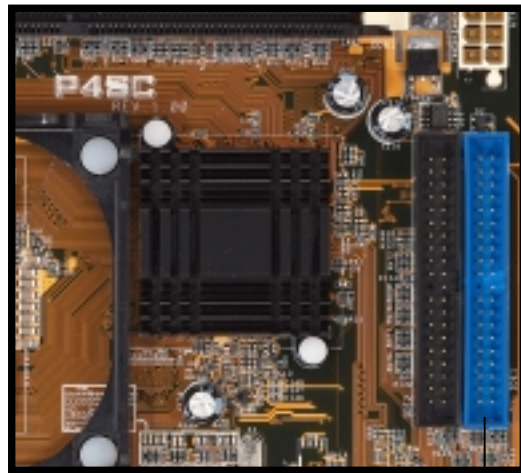

Primary IDE connector
(IDE1)

2.7 Install a CD-ROM drive

A CD-ROM drive is an optional item in this barebone system. Refer to the instructions in this section if you acquired a model without a CD-ROM.

Follow these steps to install a CD-ROM drive.

1. Place the chassis upright.
2. Insert the CD-ROM drive into the upper 5.25-inch drive bay.



5.25-inch drive bay

3. Carefully push the CD-ROM drive into the bay until its screw holes align with the holes (marked 1) on the bay as shown.
4. Secure the CD-ROM with two screws on each side of the bay.



CD-ROM screws

5. Connect a power cable from the power supply to the power connector at the back of the CD-ROM. Use the cable with the white connector labeled P1.
6. Connect one end of the IDE ribbon cable to the IDE interface at the back of the CD-ROM, matching the red stripe on the cable with Pin 1 on the IDE interface.
7. Connect one end of the CD-ROM audio cable to the 4-pin connector at the back of the CD-ROM.
8. Connect the other end of the IDE ribbon cable to the secondary IDE connector (black connector labeled IDE2) on the motherboard.



CD-ROM Audio Cable
 IDE Ribbon Cable
 Red Stripe to Pin 1
 Power Cable (P1)

9. Connect the other end of the audio cable to the black 4-pin connector labeled CD on the motherboard.

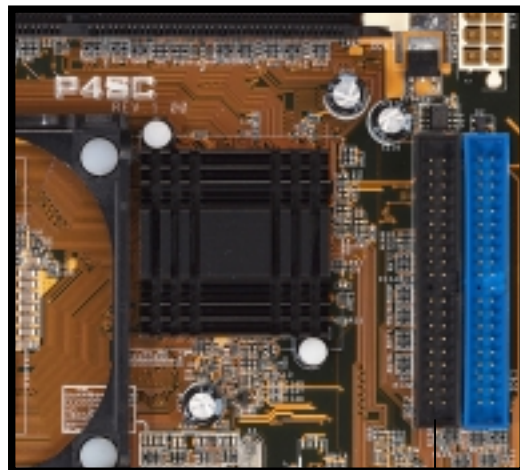

Secondary IDE connector (IDE2)

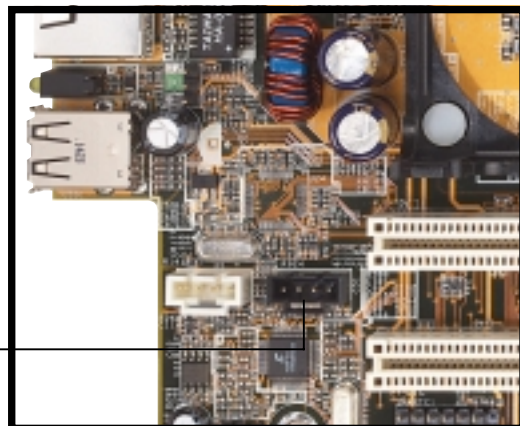

CD-ROM Connector (CD1)

2.8 Install a PCI expansion card

The motherboard has two 32-bit PCI slots. If you wish to install a PCI card, follow the instructions in this section.

The figure on the right shows a sample PCI network card that you can install on the PCI slot.

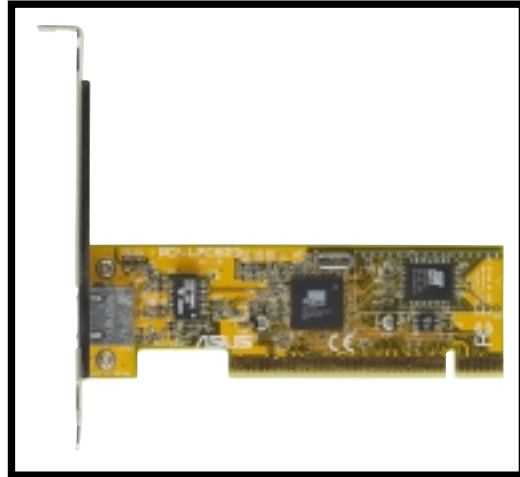

Follow these steps to install a PCI expansion card.

1. Place the chassis on its side.
2. Remove the metal bracket cover opposite the PCI slot that you wish to use.
3. Align the PCI card golden fingers to the PCI slot and its metal bracket to the slot opening on the chassis.
4. Press the card firmly until it is properly seated on the slot.
5. Secure the card to the chassis with a bracket screw.

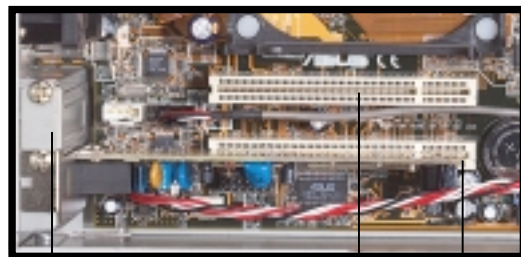

Slot Opening

PCI Slot 1 (PCI1)

PCI Slot 2 (PCI2)

NOTE

If your system came with the optional modem card, one PCI slot is already occupied.

2.9 Re-connect cables

You may have disconnected some cables when you were installing components. You must re-connect these cables before you replace the chassis cover.

2.9.1 Front panel

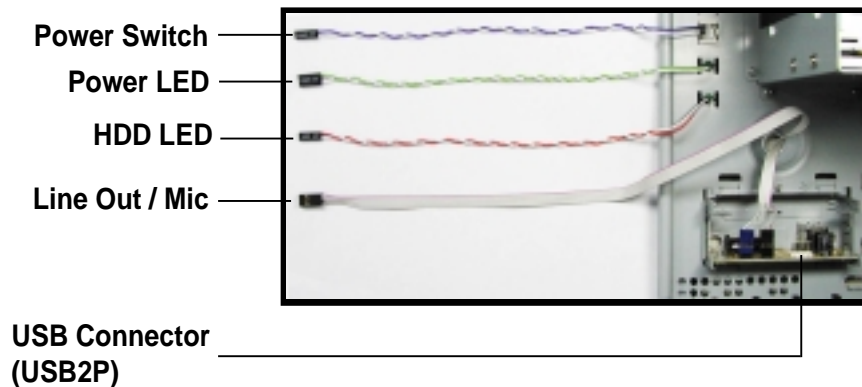

1. Connect the power switch and power LED cables to their respective leads in the HPANEL connector on the motherboard.
2. Connect the HDD LED cable to the 2-pin lead marked IDELED1.
3. Connect the Line Out/Mic cable to the MIC_LOUT connector on the motherboard, matching the red pin stripe with Pin 1.
4. Connect the USB2P cable to the USB2 connector on the motherboard, matching the red pin stripe with Pin 1.

2.9.2 UAEX extension module

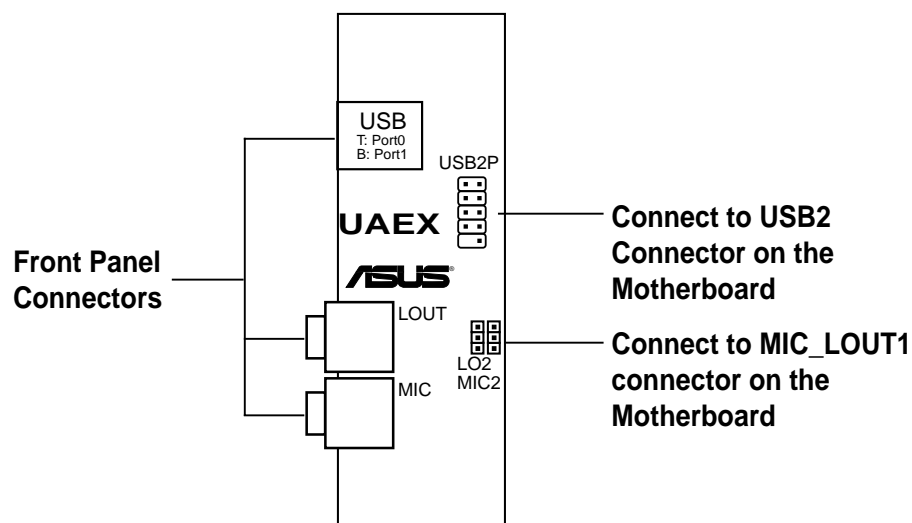

2.9.3 Motherboard

The figures below show the specific connectors on the motherboard where the front panel cables must be connected. You must re-connect these cables before replacing the chassis cover.

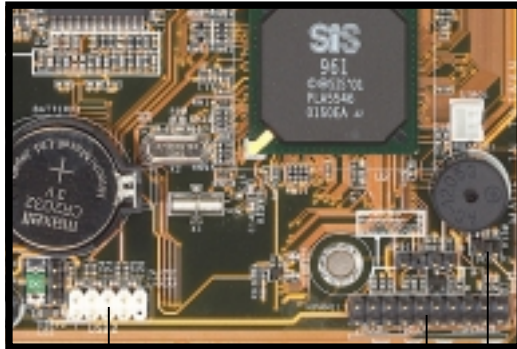

USB2 Connector
 HPANEL1 Connector
 IDE LED Connector

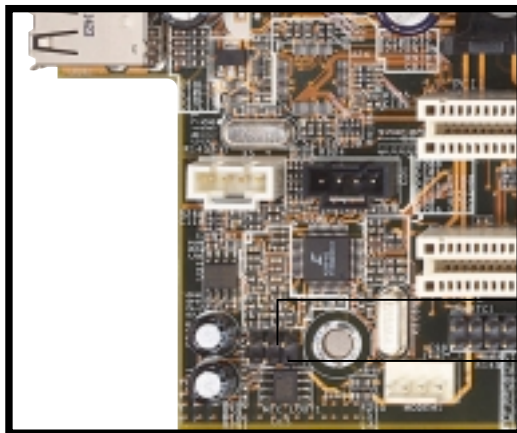
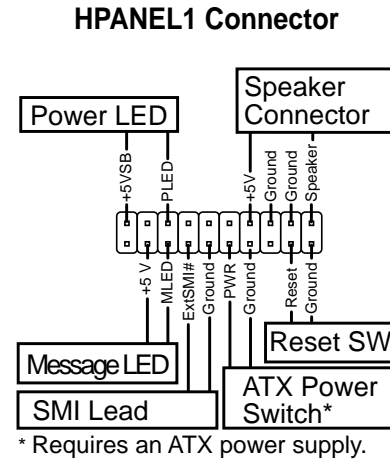

MIC Lead (for Microphone Cable)
 LOUT Lead (for Line Out Cable)

2.10 Replace the cover

After you have installed all the internal components and you have connected all the necessary cables, you are now ready to put the system back together.

Follow these steps to re-assemble the system.

1. With the chassis lying on its side, hook the swivel edge of the drive frame to the main chassis.
2. Sway the drive frame inward until it fits completely. The protruding tabs on both ends of the drive frame should snap perfectly to the chassis edge.



Protruding Tab

3. Turn the chassis upright.
4. Place the cover over the chassis leaving about two inches from the rear panel.



5. Fit the rail tabs on the sides and bottom of the cover to the edges of the chassis.

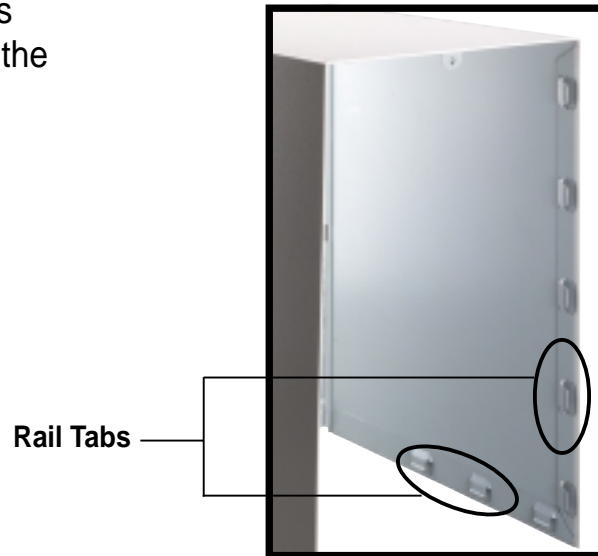

6. Push the cover towards the rear until it fits. The locking tab snaps into the hole on the chassis indicating that the cover is in place.

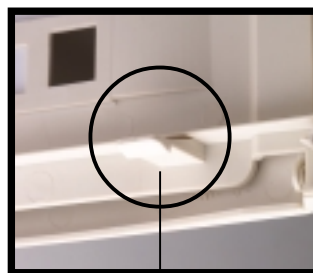

Locking Tab



Locking Tab Hole

IMPORTANT

Firmly push the cover to ensure that it is fully engaged to the chassis.

7. Lock the cover with the captive thumbscrew on the rear panel.

2.11 Connect External Devices

The figure below shows the specific connectors and devices that you can connect to the rear panel ports.

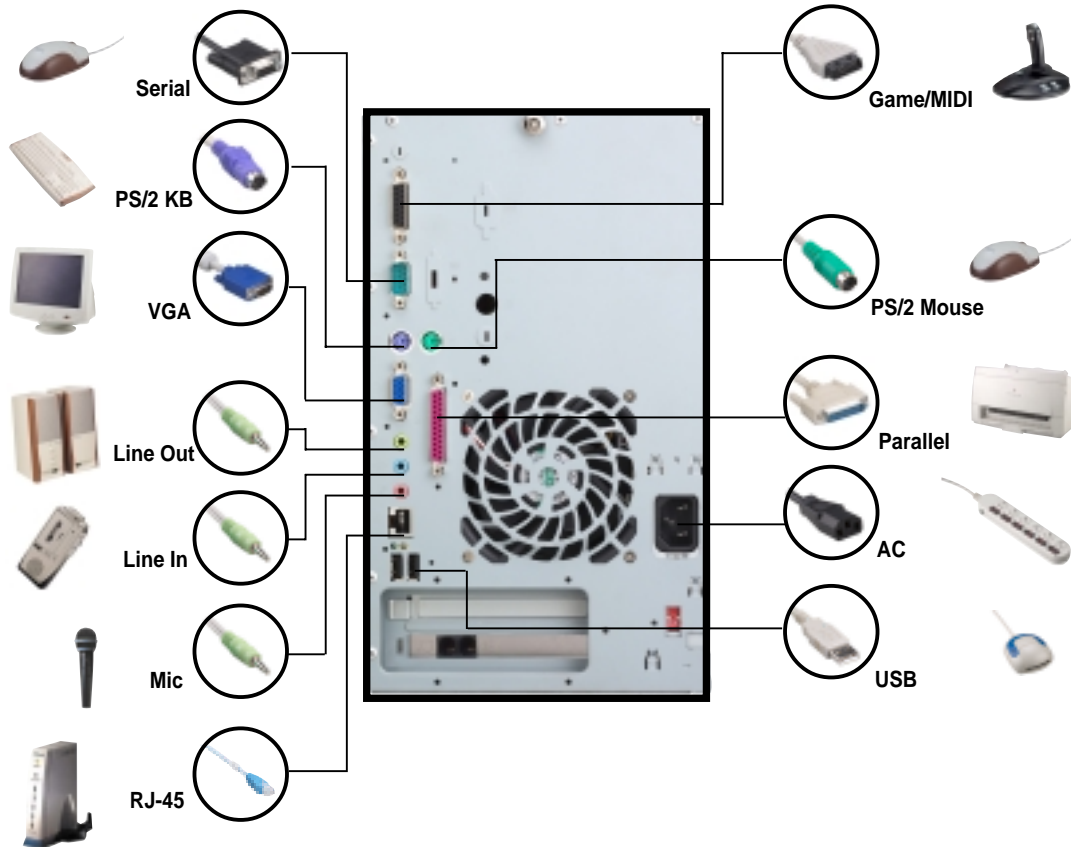

2.12 Power Supply Specifications

2.12.1 Input Characteristics

Input Voltage Range	Min	Nom	Max
Range 1	90V	115V	135V
Range 2	180V	230V	265V
Input Frequency Range	47 Hz to 63 Hz		
Maximum Input ac Current	4A max. at 115Vac 2A max. at 230Vac, maximum load		
Inrush Current	90A max. at 115Vac, full load cold start at 25°C		
Efficiency	70% min. at nominal input, maximum load		

2.12.2 Output Characteristics

Output Voltage	Load Range		Regulation		Ripple
	Min	Max	Min	Max	Max
+5V	0.5A	4.0A	-5%	+5%	50mV _{p-p}
+12V	0.45A	9.5A	-5%	+5%	120mV _{p-p}
-12V	0A	0.2A	-10%	+10%	120mV _{p-p}
+5VSB	0.05A	1.5A	-5%	+5%	50mV _{p-p}
+3V3	1A	8.0A	-5%	+5%	50mV _{p-p}

2.12.3 Over-Voltage Protection (OVP)

Output Voltage	Maximum Voltage
+5V	6.5V
+12V	15.6V
+3.3V	4.3V

NOTE

The power supply will shut down and latch off for shorting +5V, +12V, -12V, or +3.3V. By shorting +5VSB, the power supply can latch down or automatically recover when the fault condition is removed