



# Test Report

Product Name : Mother Board with CD-RW  
Model No. : P4B533-E with CRW-4816A

Applicant	ASUSTeK COMPUTER INC.
Address	4Fl., No. 150, Li-Te Rd., Peitou, Taipei, Taiwan, R.O.C.

Date of Receipt	March 15, 2002
Date of Test	April 29, 2002
Report No.	024L047E

The Test Results relate only to the samples tested.  
The test report shall not be reproduced except in full without the written approval of Quietek Corporation.



# Declaration of Conformity

The following products is herewith confirmed to comply with the requirements set out in the Council Directive on the Approximation of the laws of the Member States relating to Electromagnetic Compatibility Directive (89/336/EEC). The listed standard as below were applied:

The following Equipment:

Product : Mother Board with CD-RW  
Trade Name : ASUS  
Model Number : P4B533-E with CRW-4816A

This product is herewith confirmed to comply with the requirements set out in the Council Directive on the Approximation of the laws of the Member States relating to Electromagnetic Compatibility Directive (89/336/EEC). For the evaluation regarding EMC, the following standards were applied:

## RFI Emission:

EN 55022:1998 Class B : Product family standard  
EN 61000-3-2:1995 Class D : Limits for harmonic current emission  
Amendment 1:1998  
Amendment 2:1998  
Amendment 14:2000  
EN 61000-3-3:1995 : Limitation of voltage fluctuation and flicker in low-voltage supply system

## Immunity :

EN 55024:1998 Product family standard

The following importer/manufacturer is responsible for this declaration:

Company Name : \_\_\_\_\_  
Company Address : \_\_\_\_\_  
Telephone : \_\_\_\_\_ Facsimile : \_\_\_\_\_

Person is responsible for marking this declaration:

\_\_\_\_\_  
Name (Full Name)

\_\_\_\_\_  
Position/ Title

\_\_\_\_\_  
Date

\_\_\_\_\_  
Legal Signature



EMC/Safety Test Laboratory  
Accredited by DNV, TUV, Nemko and NVLAP

Date: April 29, 2002  
QTK No.: 024L047E



## Statement of Conformity

The certifies that the following designated product

Product : Mother Board with CD-RW  
Trade Name : ASUS  
Model Number : P4B533-E with CRW-4816A  
Company Name : ASUSTeK COMPUTER INC.

This product is herewith confirmed to comply with the requirements set out in the Council Directive on the Approximation of the laws of the Member States relating to Electromagnetic Compatibility Directive (89/336/EEC). For the evaluation regarding EMC, the following standards were applied:

**RFI Emission:**

EN 55022:1998 Class B : Product family standard  
EN 61000-3-2:1995 Class D : Limits for harmonic current emission  
Amendment 1:1998  
Amendment 2:1998  
Amendment 14:2000  
EN 61000-3-3:1995 : Limitation of voltage fluctuation and flicker in low-voltage supply system

**Immunity :**

EN 55024:1998 Product family standard



TEST LABORATORY

  
Gene Chang/ Manager

The verification is based on a single evaluation of one sample of above-mentioned products. It does not imply an assessment of the whole production and does not permit the use of the test lab. Logo.

# Test Report Certification

Test Date : April 29, 2002  
Report No. : 024L047E





Accredited by TUV, DNV, Nemko and NIST (NVLAP)

Product Name : Mother Board with CD-RW  
Applicant : ASUSTeK COMPUTER INC.  
Address : 4Fl., No. 150, Li-Te Rd., Peitou, Taipei, Taiwan, R.O.C.  
Manufacturer : ASUSTeK COMPUTER INC.  
Model No. : P4B533-E with CRW-4816A  
Rated Voltage : Power by PC  
Trade Name : ASUS  
Measurement Standard : EN 55022:1998 Class B  
EN 61000-3-2:1995, Amendment 1:1998, Amendment 2:1998  
Amendment 14:2000, EN 61000-3-3:1995, EN 55024:1998  
Measurement Procedure : EN 55022:1998, EN 61000-3-2:1995, EN 61000-3-3:1995,  
IEC 61000-4-2:1995, IEC 61000-4-3:1995, IEC 61000-4-4:1995,  
IEC 61000-4-5:1995, IEC 61000-4-6:1996, IEC 61000-4-8:1993,  
IEC 61000-4-11:1994  
Test Result : Complied

The Test Results relate only to the samples tested.

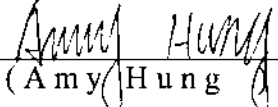
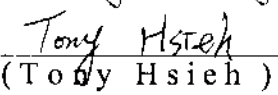
The test report shall not be reproduced except in full without the written approval of Quietek Corporation.

Documented By :   
( Amy Hung )  
Tested By :   
( Tony Hsieh )  
Reviewed By :   
( Wallace Pan )  
Approved By :   
( Gene Chang )

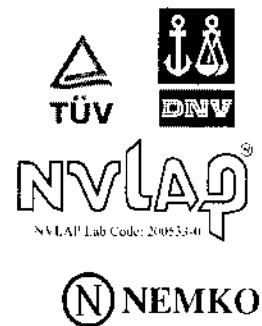

## Test Report Certification



Quietek Corporation

Test Date : April 29, 2002

Report No. : 024L047E

Accredited by TUV, DNV, Nemko and NIST (NVLAP)

Product Name : Mother Board with CD-RW

Applicant : ASUSTeK COMPUTER INC.

Address : 4Fl., No. 150, Li-Te Rd., Peitou, Taipei, Taiwan, R.O.C.

Manufacturer : ASUSTeK COMPUTER INC.

Model No. : P4B533-E with CRW-4816A

Rated Voltage : Power by PC

Trade Name : ASUS

Measurement Standard : AS/NZS 3548: 1995

Measurement Procedure : AS/NZS 3548: 1995

Test Result : Complied

The Test Results relate only to the samples tested.

The test report shall not be reproduced except in full without the written approval of Quietek Corporation.

Documented By : *Amy Hung*  
( Amy Hung )

Tested By : *Tony Hsieh*  
( Tony Hsieh )

Reviewed By : *Wallace Pan*  
( Wallace Pan )

Approved By : *Gene Chang*  
( Gene Chang )



# TABLE OF CONTENTS

Description	Page
<b>1. General Information .....</b>	<b>6</b>
1.1. EUT Description.....	6
1.2. Tested System Details.....	7
1.3. Configuration of tested System .....	9
1.4. EUT Exercise Software .....	9
1.5. Test Facility .....	10
<b>2. Conducted Emission.....</b>	<b>11</b>
2.1. Test Equipment List.....	11
2.2. Test Setup .....	11
2.3. Limits .....	12
2.4. Test Procedure .....	12
2.5. Test Specification .....	12
2.6. Test Result .....	12
<b>3. Radiated Emission.....</b>	<b>13</b>
3.1. Test Equipment.....	13
3.2. Test Setup .....	13
3.3. Limits .....	14
3.4. Test Procedure .....	14
3.5. Test Specification .....	14
3.6. Test Result .....	14
<b>4. Power Harmonics and Voltage Fluctuation .....</b>	<b>15</b>
4.1. Power Harmonics and Voltage Fluctuation Test Equipment List .....	15
4.2. Test Setup .....	15
4.3. Limits .....	15
4.4. Test Procedure .....	16
4.5. Test Specification .....	16
4.6. Test Result .....	16
<b>5. Electrostatic Discharge (ESD).....</b>	<b>17</b>
5.1. Test Equipment.....	17
5.2. Test Setup .....	17
5.3. Test Level .....	17
5.4. Test Procedure .....	18
5.5. Test Specification .....	18
5.6. Test Result .....	18
<b>6. Radiated Susceptibility (RS).....</b>	<b>19</b>
6.1. Test Equipment.....	19
6.2. Test Setup .....	19
6.3. Test Level .....	19
6.4. Test Procedure .....	20
6.5. Test Specification .....	20
6.6. Test Result .....	20
<b>7. Electrical Fast Transient/Burst (EFT/B) .....</b>	<b>21</b>
7.1. Test Equipment.....	21
7.2. Test Setup .....	21
7.3. Test Level .....	21
7.4. Test Procedure .....	22
7.5. Test Specification .....	22
7.6. Test Result .....	22
<b>8. Surge.....</b>	<b>23</b>
8.1. Test Equipment.....	23
8.2. Test Setup .....	23
8.3. Test Level .....	23

8.4.	Test Procedure .....	24
8.5.	Test Specification .....	24
8.6.	Test Result .....	24
<b>9.</b>	<b>Conducted Susceptibility (CS).....</b>	<b>25</b>
9.1.	Test Equipment.....	25
9.2.	Test Setup .....	25
9.3.	Test Level .....	26
9.4.	Test Procedure .....	26
9.5.	Test Specification .....	26
9.6.	Test Result .....	26
<b>10.</b>	<b>Power Frequency Magnetic Field .....</b>	<b>27</b>
10.1.	Test Equipment.....	27
10.2.	Test Setup .....	27
10.3.	Test Level .....	27
10.4.	Test Procedure .....	28
10.5.	Test Specification .....	28
10.6.	Test Result .....	28
<b>11.</b>	<b>Voltage Dips and Interruption Measurement .....</b>	<b>29</b>
11.1.	Test Equipment.....	29
11.2.	Test Setup .....	29
11.3.	Test Level .....	29
11.4.	Test Procedure .....	30
11.5.	Test Specification .....	30
11.6.	Test Result .....	30
<b>12.</b>	<b>EMC Reduction Method During Compliance Testing.....</b>	<b>31</b>
<b>13.</b>	<b>Test Result .....</b>	<b>32</b>
13.1.	Test Data of Conducted Emission .....	33
13.2.	Test Data of Radiated Emission .....	35
13.3.	Test Data of Power Harmonics.....	39
13.4.	Test Data of Electrostatic Discharge .....	45
13.5.	Test Data of Radiated Susceptibility .....	46
13.6.	Test Data of Electrical Fast Transient.....	47
13.7.	Test Data of Surge .....	48
13.8.	Test Data of Conducted Susceptibility .....	49
13.9.	Test Data of Power Frequency Magnetic Field .....	50
13.10.	Test Data of Voltage Dips and Interruption .....	51

Attachment 1: EUT Test Photographs  
 Attachment 2: EUT Detailed Photographs  
 Reference : Laboratory of License

## 1. General Information

### 1.1. EUT Description

Product Name	Mother Board with CD-RW
Trade Name	ASUS
Model No.	P4B533-E with CRW-4816A
EUT Voltage	Power by PC

Note:

- The EUT is a Mother Board, which can support Intel Pentium-4 CPU (2.4GHz/ 133MHz, 2.2GHz/100MHz) °
- The EUT have one PS/2 keyboard port, one PS/2 mouse port, six USB ports, two Com ports, two 1394 Device ports, one printer port, one LAN port, one Line-out port, one Line-in port, one Microphone-in port and one game port.
- Quietek has verified the construction and function in typical operation. All the test modes were carried out with the EUT in normal operation, which was shown in this test report and defined as:

EMI Mode	Mode 1: P4 2.4GHz/133MHz+R/W Mode
	Mode 2: P4 2.2GHz/100MHz+Read Mode
EMS Mode	Mode 1: P4 2.4GHz/133MHz+R/W Mode



## 1.2. Tested System Details

The types for all equipment, plus descriptions of all cables used in the tested system (including inserted cards ) are:

	Product	Manufacturer	Model No.	Serial No.
(1)	PC			
	Chassis	Chenbro	B6251-200	N/A
	Mother board(EUT)	Asus	P4B533-E	N/A
	CPU	Intel Pentium-4 2.4GHz/133MHz Intel Pentium-4 2.2GHz/100MHz		
	H.D.D.	Quantum	LM30A011	N/A
	CD-RW(EUT)	Asus	CRW-4816A	N/A
	F.D.D.	NEC	FD1231H	N/A
	VGA Card	ASUS	V7700TI	N/A
	Sound Card	On Board		
	LAN Card	On Board		
	S.P.S.	Seven team	ST-250BLP	N/A
(2)	Monitor	ADI	CM703	038054T10203890A
(3)	Modem	ACEEX	DM-1414	0102027559
(4)	Modem	ACEEX	DM-1414	0102027542
(5)	Walkman	AIWA	HS-TA164	N/A
(6)	Microphone & Earphone	TOKTO	SX-MI	N/A
(7)	Keyboard	HP	SK-2506	C00083358
(8)	Digital 8 (D8)	SONY	DCR-TRV5250	1081754
(9)	Earphone	AIWA	N/A	N/A
(10)	Mouse	HITACHI	PC-KM1300	N/A
(11)	USB Mouse	Logitech	M-BE58	LZE11405011
(12)	External HDD	FUJITSU	S/N:R129Y19003LJ	N/A
(13)	USB Mouse	Logitech	M-BE58	LZE11405306
(14)	USB Mouse	Logitech	M-BE58	LZE11405342
(15)	USB Mouse	Logitech	M-BE58	LZE11405339
(16)	USB Mouse	Logitech	M-BE58	LZE11405150
(17)	Joystick	GENIUS	MAXFIRE FORCE G-09D	CJ0100200573
(18)	External HDD	SKYMASTER	DEM-1351	N/A
(19)	Printer	EPSON	Color 680	026415

Note: 1. The power cord of the device 1, 2, 3, 4 , 18and 19 are non-shielded power cord.

Signal Cable Type		Signal cable Description
A.	RS232 cable	Shielded, 1.5m
B.	RS232 cable	Shielded, 1.5m
C.	Audio cable	Non-Shielded, 1.5m
D.	VGA cable	Shielded, 1.8m with core*1
E.	Microphone&Earphone cable	Non-Shielded, 1.8m
F.	Keyboard data cable	Shielded, 1.8m
G.	1394 cable	Shielded, 1.2m
H.	PS/2 Mouse cable	Shielded, 1.0m
I.	Earphone cable	Non-Shielded, 1.8m
J.	USB mouse cable	Shielded, 1.8m
K.	USB cable	Shielded, 1.0m
L.	USB mouse cable	Shielded, 1.8m
M.	USB mouse cable	Shielded, 1.8m
N.	USB mouse cable	Shielded, 1.8m
O.	USB mouse cable	Shielded, 1.8m
P.	Joystick cable	Shielded, 1.8m
Q.	1394 cable	Shielded, 1.8m
R.	Printer cable	Shielded, 1.9m
S.	LAN cable	Non-Shielded, 7.0m

### 1.3. Configuration of tested System

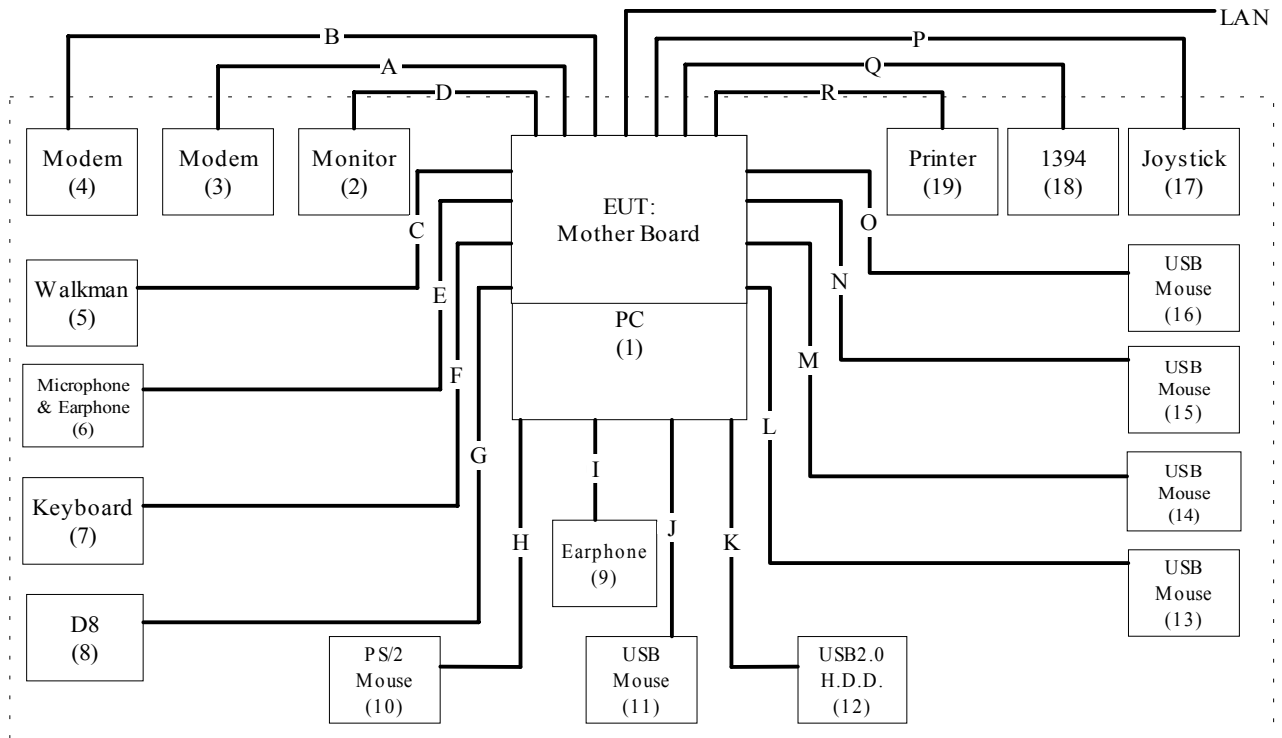

### 1.4. EUT Exercise Software

- (1) Setup the EUT and simulators as shown on 1.3.
- (2) Turn on the power of all equipment.
- (3) EUT reads data from disk.
- (4) EUT will sends “H” pattern to monitor, the monitor will show “H” pattern on the screen.
- (5) EUT sends “H” pattern to printer, the printer will print “H” pattern on paper.
- (6) EUT reads and writes data into and from modem.
- (7) EUT will read data from floppy disk and then writes the data into floppy disk, same operation for hard disk.
- (8) The CD ROM plays the audio signal and video picture during the test.
- (9) Run “Media player” test program.
- (10) Repeat the above procedure (3) to (9).

**1.5. Test Facility**

Ambient conditions in the laboratory:

Items	Test Item	Required (IEC 68-1)	Actual
Temperature (°C)	IEC 61000-4-2	15-35	20-35
Humidity (%RH)		30-60	50-65
Barometric pressure (mbar)		860-1060	950-1000
Temperature (°C)	IEC 61000-4-5	15-35	20-35
Humidity (%RH)		10-75	50-65
Barometric pressure (mbar)		860-1060	950-1000
Temperature (°C)	IEC 61000-4-4	15-35	20-35
Humidity (%RH)	IEC 61000-4-8	25-75	50-65
Barometric pressure (mbar)	IEC 61000-4-11	860-1060	950-1000

Site Description:

June 29, 2001 Accreditation on NVLAP  
 NVLAP Lab Code: 200533-0



June 11, 2001 Accreditation on DNV  
 Statement No. : 413-99-LAB11



January 04, 1999 Accreditation on TUV Rheinland  
 Certificate No.: I9865712-9901



April 18, 2001 Accreditation on Nemko  
 Certificate No.: ELA 165  
 Certificate No.: ELA 162



Site Name: Quietek Corporation

Site Address: N0.5-22, Ruei-Shu Valley, Rue-Ping Tsuen, Lin Kou  
 Shiang, Taipei 244, Taiwan, R.O.C.

TEL : 886-2-8601-3788 / FAX : 886-2-8601-3789

E-Mail : [service@quietek.com](mailto:service@quietek.com)

**2. Conducted Emission**

**2.1. Test Equipment List**

The following test equipment are used during the conducted emission test:

Item	Instrument	Manufacturer	Type No./Serial No	Last Cal..	Remark
1	Test Receiver	R & S	ESCS 30/838251/0001	May, 2001	
2	L.I.S.N.	R & S	ESH3-Z5/836679/0023	May, 2001	EUT
3	L.I.S.N.	R & S	ENV 4200/833209/0023	May, 2001	Peripherals
4	Pulse Limiter	R & S	ESH3-Z2	May, 2001	
5	N0.4 Shielded Room			N/A	

Note: All equipment upon which need to calibrated are with calibration period of 1 year.

**2.2. Test Setup**

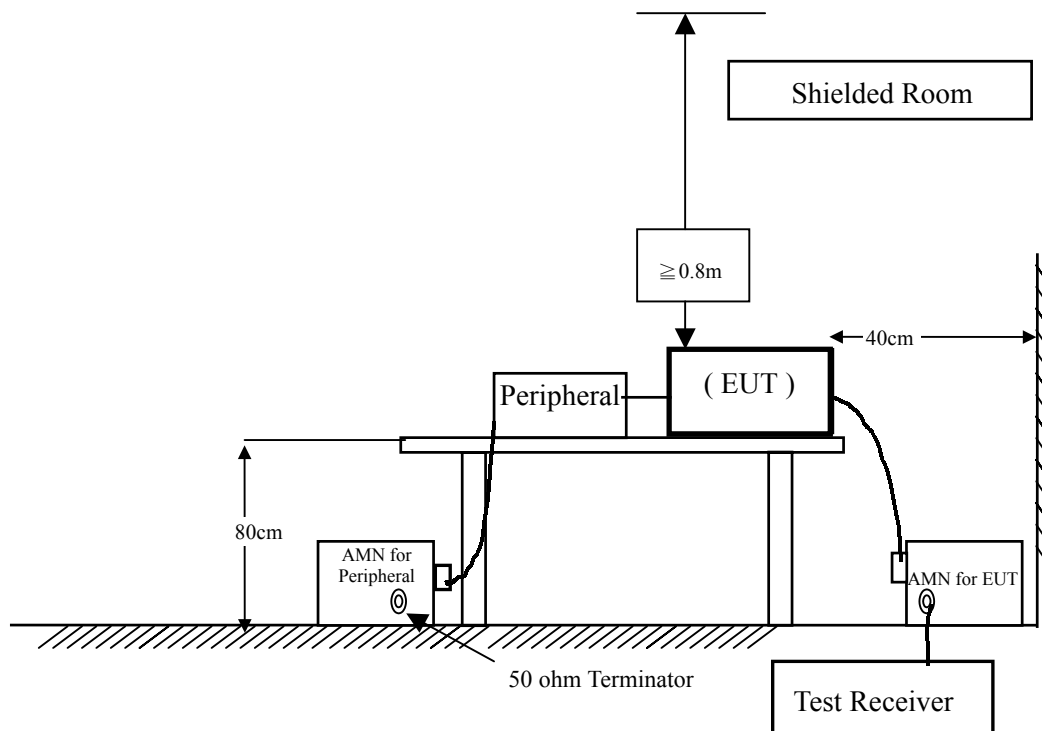

**2.3. Limits**

<b>EN 55022 Limits (dBuV)</b>				
Frequency MHz	Class A		Class B	
	QP	AV	QP	AV
0.15 - 0.50	79	66	66-56	56-46
0.50-5.0	73	60	56	46
5.0 - 30	73	60	60	50

Remarks : In the above table, the tighter limit applies at the band edges.

**2.4. Test Procedure**

The EUT and simulators are connected to the main power through a line impedance stabilization network (L.I.S.N.). This provides a 50 ohm /50uH coupling impedance for the measuring equipment. The peripheral devices are also connected to the main power through a LISN that provides a 50ohm /50uH coupling impedance with 50ohm termination. (Please refers to the block diagram of the test setup and photographs.)

Both sides of A.C. line are checked for maximum conducted interference. In order to find the maximum emission, the relative positions of equipment and all of the interface cables must be changed according to EN 55022:1998 on conducted measurement.

Conducted emissions were investigated over the frequency range from 0.15MHz to 30MHz using a receiver bandwidth of 9kHz.

**2.5. Test Specification**

According to EN 55022:1998

**2.6. Test Result**

The emission from the EUT was below the specified limits. The worst-case emissions are shown in section 13. The acceptance criterion was met and the EUT passed the test.

### 3. Radiated Emission

#### 3.1. Test Equipment

The following test equipment are used during the radiated emission test:

Test Site	Equipment	Manufacturer	Model No./Serial No.	Last Cal.
<input checked="" type="checkbox"/> Site # 1	Test Receiver	R & S	ESVS 10 / 834468/003	July, 2001
	Spectrum Analyzer	Advantest	R3162/ 00803480	May, 2001
	Pre-Amplifier	Advantest	BB525C/ 3307A01812	May, 2001
	Bilog Antenna	SCHAFFNER	CBL6112B / 2697	Nov., 2001
<input type="checkbox"/> Site # 2	Test Receiver	R & S	ESCS 30 / 836858 / 022	Nov., 2001
	Spectrum Analyzer	Advantest	3162 / 100803466	May, 2001
	Pre-Amplifier	Advantest	BB525C/3307A01814	May, 2001
	Bilog Antenna	SCHAFFNER	CBL6112B / 2705	Oct., 2001
	Horn Antenna	ETS	3115 / 0005-6160	July, 2001
	Pre-Amplifier	QTK	QTK-AMP-01/ 0001	July, 2001
<input type="checkbox"/> Site # 3	Test Receiver	R & S	ESI 26 / 838786 / 004	May, 2001
	Spectrum Analyzer	Advantest	3162 / 100803480	May, 2001
	Pre-Amplifier	QTK	QTK-AMP-03 / 0003	May, 2001
	Bilog Antenna	SCHAFFNER	CBL6112B / 2697	May, 2001
	Horn Antenna	ETS	3115 / 0005-6160	July, 2001
	Pre-Amplifier	QTK	QTK-AMP-01 / 0001	July, 2001

- Note:
1. All equipments that need to calibrate are with calibration period of 1 year.
  2. Mark "X" test instruments are used to measure the final test results.

#### 3.2. Test Setup

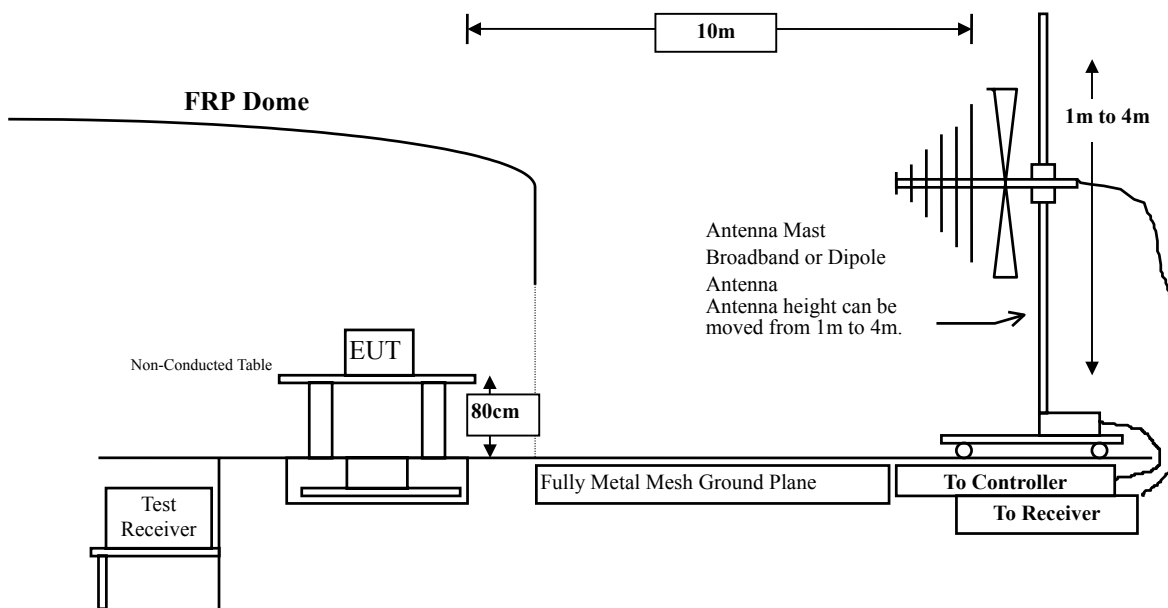

**3.3. Limits**

<b>EN 55022 Limits (dBuV/m)</b>				
Frequency MHz	Class A		Class B	
	Distance (m)	dBuV/m	Distance (m)	dBuV/m
30 – 230	10	40	10	30
230 – 1000	10	47	10	37

**3.4. Test Procedure**

The EUT and its simulators are placed on a turn table which is 0.8 meter above ground. The turn table can rotate 360 degrees to determine the position of the maximum emission level. The EUT was positioned such that the distance from antenna to the EUT was 10 meters.

The antenna can move up and down between 1 meter and 4 meters to find out the maximum emission level.

Both horizontal and vertical polarization of the antenna are set on measurement. In order to find the maximum emission, all of the interface cables must be manipulated according to EN55022:1998 on radiated measurement.

Radiated emissions were investigated over the frequency range from 30MHz to 1GHz using a receiver bandwidth of 120kHz. Radiated was performed at an antenna to EUT distance of 10 meters.

**3.5. Test Specification**

According to EN 55022:1998

**3.6. Test Result**

The emission from the EUT was below the specified limits. The worst-case emissions are shown in section 13. The acceptance criterion was met and the EUT passed the test.



#### 4. Power Harmonics and Voltage Fluctuation

##### 4.1. Power Harmonics and Voltage Fluctuation Test Equipment List

Item	Instrument	Manufacturer	Type No/Serial No.	Last Calibration
1	Power Harmonics Tester	SCHAFFNER	Proflin 2105-400 S/N: HK54148	Jun., 2001
2	Analyzer	SCHAFFNER	CCN 1000-1/X71887	Jun., 2001
3	No.3 Shielded Room			N/A

Note: All equipment upon which need to calibrated are with calibration period of 1 year.

##### 4.2. Test Setup

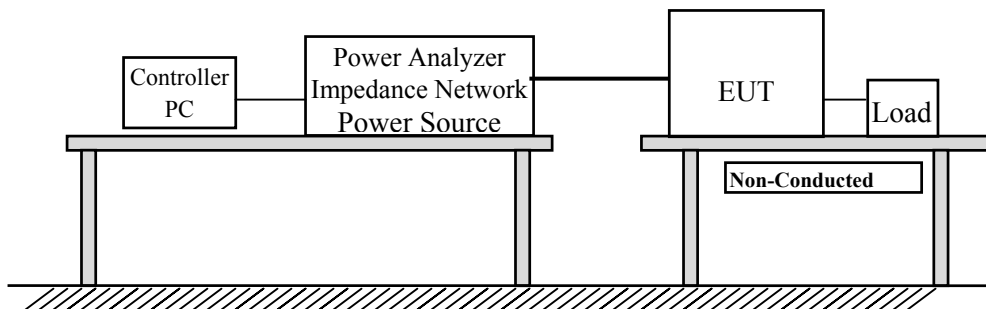

##### 4.3. Limits

➤Limits of Harmonics Currents

Harmonics Order	Maximum Permissible harmonic current (in amperes)	Harmonics Order	Maximum Permissible harmonic current (in amperes)
Odd harmonics		Even harmonics	
3	2.30	2	1.08
5	1.14	4	0.43
7	0.77	6	0.30
9	0.40	8 ≤ n ≤ 40	0.23 * 8/n
11	0.33		
13	0.21		
15 ≤ n ≤ 39	0.15 * 15/n		

#### **4.4. Test Procedure**

The EUT is supplied in series with power analyzer from a power source having the same normal voltage and frequency as the rated supply voltage and the equipment under test. And the rated voltage at the supply voltage of EUT of 0.94 times and 1.06 times shall be performed.

#### **4.5. Test Specification**

According to EN 61000-3-2:1995, , Amendment 1:1998, Amendment 2:1998, Amendment 14:2000 and EN 61000-3-3:1995

#### **4.6. Test Result**

The measurement of the power harmonics, which test at the extremes of EUT's supply range, was investigated and test result was shown in section 13. The acceptance criterion was met and the EUT passed the test.

## 5. Electrostatic Discharge (ESD)

### 5.1. Test Equipment

Item	Instrument	Manufacturer	Type No/Serial No.	Last Calibration
1	ESD Simulator System	KeyTek	MZ-15/EC S/N: 0112372	Jun., 2001
2	Horizontal Coupling Plane(HCP)	Quietek	HCP AL50	N/A
3	Vertical Coupling Plane(VCP)	Quietek	VCP AL50	N/A
4	No.3 Shielded Room			N/A

Note: All equipment upon which need to calibrated are with calibration period of 1 year.

### 5.2. Test Setup

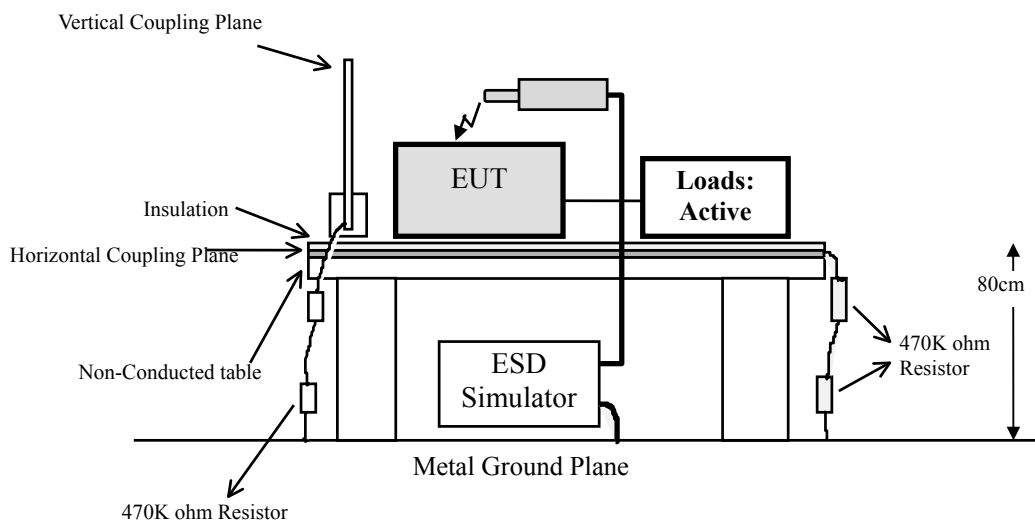

### 5.3. Test Level

Item	Environmental Phenomena	Units	Test Specification	Performance Criteria
<b>Enclosure Port</b>				
	Electrostatic Discharge	kV(Charge Voltage)	± 8 Air Discharge ± 4 Contact Discharge	B

Remark:

The Contact discharges were applied – at least total 200 discharges at a minimum of four test points.

#### **5.4. Test Procedure**

Direct application of discharges to the EUT:

Contact discharge was applied only to conductive surfaces of the EUT.

Air discharges were applied only to non-conductive surfaces of the EUT.

During the test, it was performed with single discharges. For the single discharge time between successive single discharges will be keep longer 1 second. It was at least ten single discharges with positive and negative at the same selected point.

The selected point, which was performed with electrostatic discharge, was marked on the red label of the EUT.

Indirect application of discharges to the EUT:

Vertical Coupling Plane (VCP):

The coupling plane, of dimensions 0.5m x 0.5m, is placed parallel to, and positioned at a distance 0.1m from, the EUT, with the Discharge Electrode touching the coupling plane.

The four faces of the EUT will be performed with electrostatic discharge. It was at least ten single discharges with positive and negative at the same selected point.

Horizontal Coupling Plane (HCP):

The coupling plane is placed under to the EUT. The generator shall be positioned vertically at a distance of 0.1m from the EUT, with the Discharge Electrode touching the coupling plane.

The four faces of the EUT will be performed with electrostatic discharge. It was at least ten single discharges with positive and negative at the same selected point.

#### **5.5. Test Specification**

According to IEC 61000-4-2:1995

#### **5.6. Test Result**

The measurement of the electrostatic discharge was investigated and test result was shown in section 13. The acceptance criterion was met and the EUT passed the test.

## 6. Radiated Susceptibility (RS)

### 6.1. Test Equipment

Item	Instrument	Manufacturer	Type No/Serial No.	Last Calibration
1	Signal Generator	IFR	2023B / 202302/581	May, 2001
2	Power Amplifier	A & R	500A100AM3 /29369	Aug., 2001
3	Power Amplifier	SCHAFFNER	CBA9413B / 0006	June, 2001
4	Field Strength Sensor	SCHAFFNER	EMC 20 / Y-0028/ Z-0003	June, 2001
5	Power Antenna	SCHWARZBECK	VULB 9166 / 1073	Sep., 2001
6	Power Meter	BOONTON	4232A / 42201	May, 2001
7	No.2 EMC Fully Chamber			July, 2001

Note: All equipment upon which need to calibrated are with calibration period of 1 year.

### 6.2. Test Setup

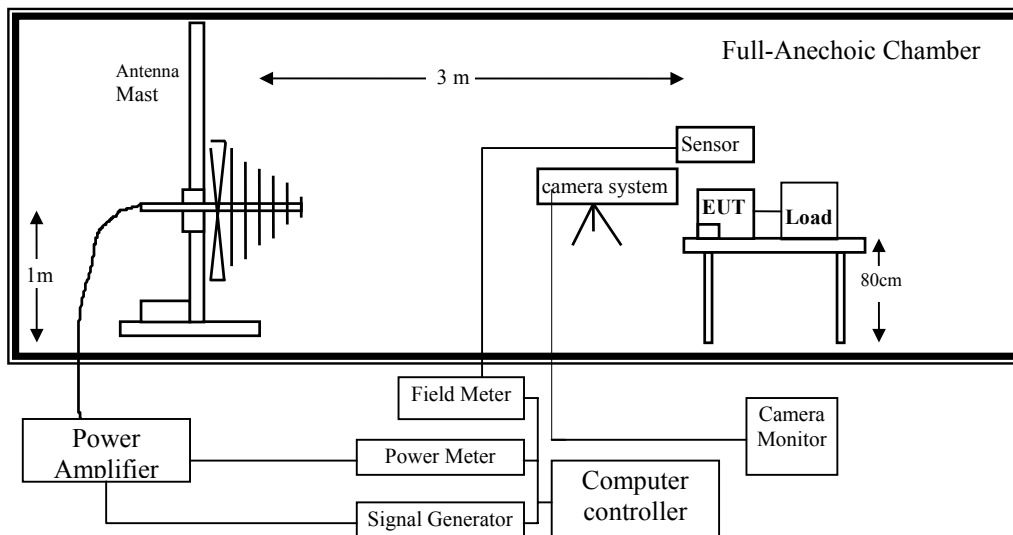

### 6.3. Test Level

Item	Environmental Phenomena	Units	Test Specification	Performance Criteria
Enclosure Port				
	Radio-Frequency	MHz	80-1000	
	Electromagnetic Field	V/m(Un-modulated, rms)	3	A
	Amplitude Modulated	% AM (1kHz)	80	

#### 6.4. Test Procedure

The EUT and load, which are placed on a table that is 0.8 meter above ground, are placed with one coincident with the calibration plane such that the distance from antenna to the EUT was 3 meters.

Both horizontal and vertical polarization of the antenna and four sides of the EUT are set on measurement.

In order to judge the EUT performance, a CCD camera is used to monitor EUT screen.

All the scanning conditions are as follows:

Condition of Test	Remarks
EN 55024:1998	
1. Field Strength	3 V/M Level 2
2. Radiated Signal	AM 80% Modulated with 1kHz
3. Scanning Frequency	80MHz - 1000MHz
4 Dwell Time	3 Seconds
5. Frequency step size $\Delta f$ :	1%
6. The rate of Swept of Frequency	$1.5 \times 10^{-3}$ decades/s

#### 6.5. Test Specification

According to IEC 61000-4-3:1995

#### 6.6. Test Result

The measurement of the radiated susceptibility was investigated and test result was shown in section 13. The acceptance criterion was met and the EUT passed the test.

## 7. Electrical Fast Transient/Burst (EFT/B)

### 7.1. Test Equipment

Item	Instrument	Manufacturer	Type No/Serial No.	Last Calibration
1	Fast Transient/Burst Generator	SCHAFFNER	BEST S/N: 300035-008SC	Jun., 2001
2	No.3 Shielded Room			N/A

Note: All equipment upon which need to calibrated are with calibration period of 1 year.

### 7.2. Test Setup

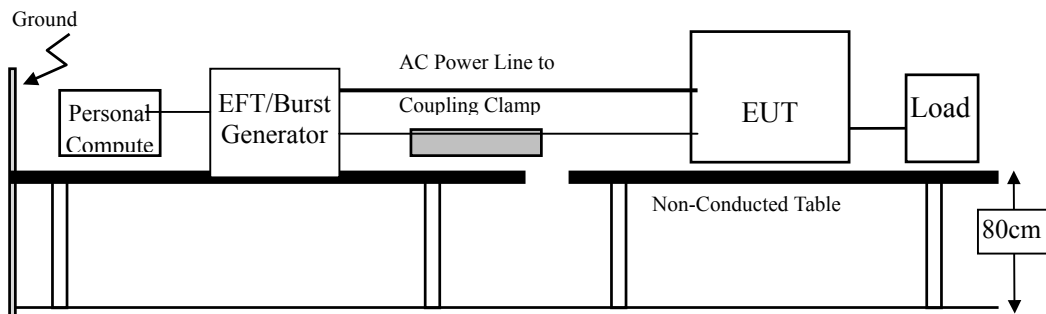

### 7.3. Test Level

Item	Environmental Phenomena	Units	Test Specification	Performance Criteria
<b>Signal Ports and Telecommunication Ports</b>				
	Fast Transients Common Mode	kV (Peak) Tr/Ts ns Rep. Frequency kHz	0.5 5/50 5	B
<b>Input DC Power Ports</b>				
	Fast Transients Common Mode	kV (Peak) Tr/Ts ns Rep. Frequency kHz	0.5 5/50 5	B
<b>Input AC Power Ports</b>				
	Fast Transients Common Mode	kV (Peak) Tr/Ts ns Rep. Frequency kHz	1 5/50 5	B

#### **7.4. Test Procedure**

The EUT and load are placed on a table that is 0.8 meter above a metal ground plane measured 1m\*1m min. and 0.65mm thick min. And projected beyond the EUT by at least 0.1m on all sides.

For Signal Ports and Telecommunication Ports:

The EFT interference signal is through a coupling clamp device couples to the signal and control lines of the EUT with burst noise for 1min.

For Input DC and AC Power Ports:

The EUT is connected to the power mains through a coupling device that directly couples the EFT interference signal.

Each of the Line and Neutral conductors is impressed with burst noise for 1 min.

The length of power cord between the coupling device and the EUT shall be 1m.

#### **7.5. Test Specification**

According to IEC 61000-4-4:1995

#### **7.6. Test Result**

The measurement of the Electrical Fast Transient/Burst was investigated and test result was shown in section 13. The acceptance criterion was met and the EUT passed the test.



**8. Surge**

**8.1. Test Equipment**

Item	Instrument	Manufacturer	Type No/Serial No.	Last Calibration
1	Surge Generator	SCHAFFNER	BEST S/N: 300035-008SC	Jun., 2001
2	No.3 Shielded Room			N/A

Note: All equipment upon which need to calibrated are with calibration period of 1 year.

**8.2. Test Setup**

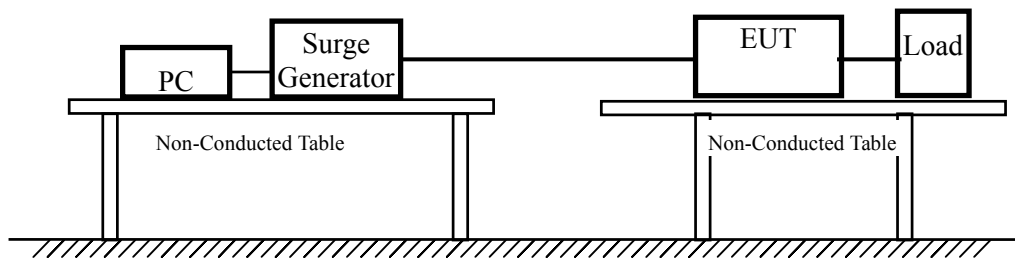

**8.3. Test Level**

Item	Environmental Phenomena	Units	Test Specification	Performance Criteria
<b>Signal Ports and Telecommunication Ports</b>				
	Surges	Tr/Ts uS	1.2/50 (8/20)	
	Line to Ground	KV	± 1	B
<b>Input DC Power Ports</b>				
	Surges	Tr/Ts uS	1.2/50 (8/20)	
	Line to Ground	kV	± 0.5	B
<b>AC Input and AC Output Power Ports</b>				
	Surges	Tr/Ts uS	1.2/50 (8/20)	
	Line to Line	kV	± 1	B
	Line to Ground	kV	± 2	

Notes:

- 1) Applicable only to ports which according to the manufacturer’s may directly to outdoor cables.
- 2) Where normal functioning cannot be achieved because of the impact of the CDN on the EUT, no test shall be required.

#### **8.4. Test Procedure**

The EUT and its load are placed on a table that is 0.8 meter above a metal ground plane measured 1m\*1m min. and 0.65mm thick min. And projected beyond the EUT by at least 0.1m on all sides. The length of power cord between the coupling device and the EUT shall be 2m or less.

For Input and Output AC Power or DC Input and DC Output Power Ports:

The EUT is connected to the power mains through a coupling device that directly couples the Surge interference signal.

The surge noise shall be applied synchronized to the voltage phase at  $0^{\circ}$ ,  $90^{\circ}$ ,  $180^{\circ}$ ,  $270^{\circ}$  and the peak value of the a.c. voltage wave. (Positive and negative)

Each of Line-Earth and Line-Line is impressed with a sequence of five surge voltages with interval of 1 min.

#### **8.5. Test Specification**

According to IEC 61000-4-5:1995

#### **8.6. Test Result**

The measurement of the Surge was investigated and test result was shown in section 13. The acceptance criterion was met and the EUT passed the test.

**9. Conducted Susceptibility (CS)**

**9.1. Test Equipment**

Item	Instrument	Manufacturer	Type No/Serial No.	Last Calibration
1	Signal Generator	IFR	2023B / 202302/581	May, 2001
2	Power Amplifier	A & R	500A100AM3 /29369	Aug., 2001
3	Power Amplifier	SCHAFFNER	CBA9413B / 0006	Jun., 2001
4	CDN 1	Schwarzbeck	L801 M2/3 / 1549	Jun., 2001
5	CDN 2	Schwarzbeck	L801 S1 / 1574	Jun., 2001
6	CDN 3	Schwarzbeck	L801 AF4 / 1064	Jun., 2001
7	CDN 4	Schwarzbeck	L801 AF8 / 1070	Jun., 2001
8	CDN 5	FCC	FCC-801-S9 / 9837	Jun., 2001
9	CDN 6	FCC	FCC-801-S15 / 9838	Jun., 2001
10	CDN 7	FCC	FCC-801-S25 / 9839	Jun., 2001
11	50 ohm Terminator	RES-NET	RCX6BM	Jun., 2001
12	6dB Attenuator	BIRD	RFA250NFF10	Jun., 2001
13	EM Clamp	Schwarzbeck	KEMZ 801 / 15928	Jun., 2001
14	No.2 EMC Fully Chamber	N/A		

Note: All equipment upon which need to calibrated are with calibration period of 1 year.

**9.2. Test Setup**

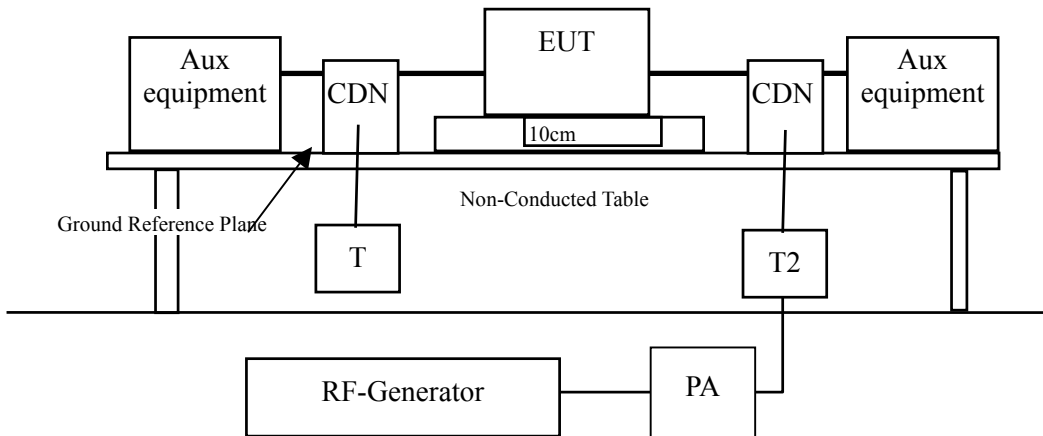

### 9.3. Test Level

Item	Environmental Phenomena	Units	Test Specification	Performance Criteria
Signal Ports and Telecommunication Ports				
	Radio-Frequency	MHz	0.15-80	
	Continuous Conducted	V (rms, Un-modulated)	3	A
		% AM (1kHz)	80	
Input DC Power Ports				
	Radio-Frequency	MHz	0.15-80	
	Continuous Conducted	V (rms, Un-modulated)	3	A
		% AM (1kHz)	80	
Input AC Power Ports				
	Radio-Frequency	MHz	0.15-80	
	Continuous Conducted	V (rms, Un-modulated)	3	A
		% AM (1kHz)	80	

### 9.4. Test Procedure

The EUT are placed on a table that is 0.8 meter height, and a Ground reference plane on the table, EUT are placed upon table and use a 10cm insulation between the EUT and Ground reference plane.

For Signal Ports and Telecommunication Ports

The disturbance signal is through a coupling and decoupling networks (CDN) or EM-clamp device couples to the signal and Telecommunication lines of the EUT.

For Input DC and AC Power Ports

The EUT is connected to the power mains through a coupling and decoupling networks for power supply lines. And directly couples the disturbances signal into EUT.

Used CDN-M2 for two wires or CDN-M3 for three wires.

All the scanning conditions are as follows:

Condition of Test	Remarks
1. Field Strength	130dBuV(3V) Level 2
2. Radiated Signal	AM 80% Modulated with 1kHz
3. Scanning Frequency	0.15MHz – 80MHz
4 Dwell Time	3 Seconds
5. Frequency step size $\Delta f$ :	1%
6. The rate of Swept of Frequency	$1.5 \times 10^{-3}$ decades/s

### 9.5. Test Specification

According to IEC 61000-4-6:1996

### 9.6. Test Result

The measurement of the Conducted Susceptibility was investigated and test result was shown in section 13. The acceptance criterion was met and the EUT passed the test.

**10. Power Frequency Magnetic Field**

**10.1. Test Equipment**

Item	Instrument	Manufacturer	Type No/Serial No.	Last Calibration
1	Power Line Maganetics	SCHAFFNER	PLINE 1610 S/N: 080 938-05	Jun., 2001
2	Gauss Meter	F.W.BELL	4090	Jun., 2001
3	Magnetic Field Coil	SCHAFFNER	INA702 S/N: 199749-020 IN	Jun., 2001
4	No.3 Shielded Room			N/A

Note: All equipment upon which need to calibrated are with calibration period of 1 year.

**10.2. Test Setup**

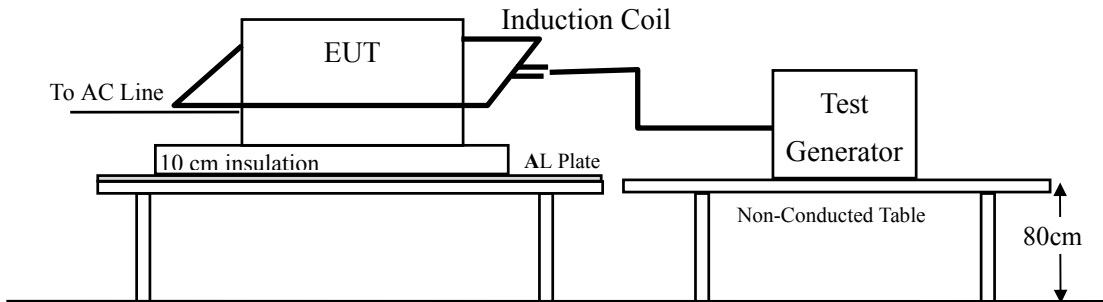

**10.3. Test Level**

Item	Environmental Phenomena	Units	Test Specification	Performance Criteria
Enclosure Port	Power-Frequency Magnetic Field	50 1	Hz A/m (r.m.s.)	A

#### **10.4. Test Procedure**

The EUT and its load are placed on a table which is 0.8 meter above a metal ground plane measured at least 1m\*1m min. The test magnetic field shall be placed at central of the induction coil.

The test magnetic Field shall be applied 10minutes by the immersion method to the EUT. And the induction coil shall be rotated by 90° in order to expose the EUT to the test field with different orientation (X, Y, Z Orientations).

#### **10.5. Test Specification**

According to IEC 61000-4-8:1993

#### **10.6. Test Result**

The measurement of the Power Frequency Magnetic Field was investigated and test result was shown in section 13. The acceptance criterion was met and the EUT passed the test.

## 11. Voltage Dips and Interruption Measurement

### 11.1. Test Equipment

Item	Instrument	Manufacturer	Type No/Serial No.	Last Calibration
1	Voltage Dips Generator	SCHAFFNER	BEST S/N:300035-008SC	Jun., 2001
2	No.3 Shielded Room			N/A

Note: All equipment upon which need to calibrated are with calibration period of 1 year.

### 11.2. Test Setup

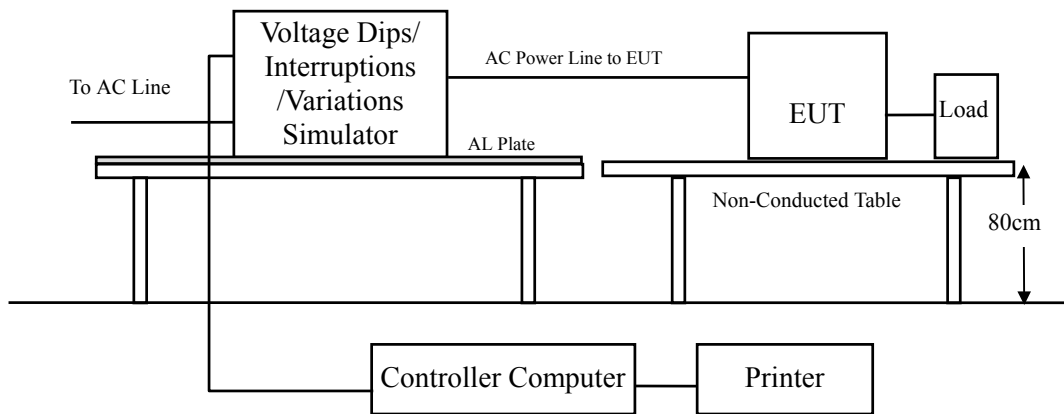

### 11.3. Test Level

Item	Environmental Phenomena	Units	Test Specification	Performance Criteria
Input AC Power Ports				
Voltage Dips		>95	% Reduction	B
		0.5	Period	
		30	% Reduction	C
25	Periods			
Voltage Interruptions		> 95	% Reduction	C
		250	Periods	

#### **11.4. Test Procedure**

The EUT and its load are placed on a table which is 0.8 meter above a metal ground plane measured 1m\*1m min. And 0.65mm thick min. And projected beyond the EUT by at least 0.1m on all sides. The power cord shall be used the shortest power cord as specified by the manufacturer.

For Voltage Dips/ Interruptions test:

The selection of test voltage is based on the rated power range. If the operation range is large than 20% of lower power range, both end of specified voltage shall be tested. Otherwise, the typical voltage specification is selected as test voltage.

The EUT is connected to the power mains through a coupling device that directly couples to the Voltage Dips and Interruption Generator.

The EUT shall be tested for 30% voltage dip of supplied voltage and duration 500ms, for 95% voltage dip of supplied voltage and duration 10ms with a sequence of three voltage dips with intervals of 10 seconds, and for 95% voltage interruption of supplied voltage and duration 5000ms with a sequence of three voltage interruptions with intervals of 10 seconds. Voltage phase shifting are shall occur at  $0^{\circ}$ ,  $45^{\circ}$ ,  $90^{\circ}$ ,  $135^{\circ}$ ,  $180^{\circ}$ ,  $225^{\circ}$ ,  $270^{\circ}$ ,  $315^{\circ}$  of the voltage.

#### **11.5. Test Specification**

According to IEC 61000-4-11:1994

#### **11.6. Test Result**

The measurement of the Voltage Dips and Interruption was investigated and test result was shown in section 13. The acceptance criterion was met and the EUT passed the test.



## 12. EMC Reduction Method During Compliance Testing

No modification was made during testing.

**13. Test Result**

The test results in the emission and the immunity were performed according to the requirements of measurement standard and process. Quietek Corporation is assumed full responsibility for the accuracy and completeness of these measurements. The test data of the emission is listed as below.

All the tests were carried out with the EUT in normal operation, which was defined as:

EMI Mode	Mode 1: P4 2.4GHz/133MHz+R/W Mode
	Mode 2: P4 2.2GHz/100MHz+Read Mode
EMS Mode	Mode 1: P4 2.4GHz/133MHz+R/W Mode

Note :

- No Deviation from standard procedure
- Deviations from standard procedure

### 13.1. Test Data of Conducted Emission

Date of Test	April 29, 2002	Test Room	No.4 Shielded Room
Test Mode	Mode 1: P4 2.4GHz/133MHz+R/W Mode	Product	Mother Board with CD-RW
Test Condition	Line1 & Line2	Test Range	0.15MHz – 30MHz

Frequency MHz	Measurement Level (dBuV)				Limits (dBuV)	
	Line1 QP	Line1 AV	Line2 QP	Line2 AV	QP	AV
0.166	42.38	40.21	--	--	65.18	55.18
0.166	--	--	49.53	45.91	65.18	55.18
0.201	--	--	40.00	38.01	63.58	53.58
0.232	35.99	33.91	--	--	62.38	52.38
0.302	32.16	30.31	--	--	60.18	50.18
0.302	--	--	37.16	33.61	60.18	50.18
0.404	27.24	25.81	--	--	57.77	47.77
0.431	--	--	29.00	25.01	57.23	47.23
7.088	--	--	25.72	25.41	60.00	50.00
7.603	27.96	26.22	--	--	60.00	50.00
22.572	34.86	31.65	--	--	60.00	50.00
22.572	--	--	34.41	31.25	60.00	50.00

Note:

1. All Reading Levels are Quasi-Peak and average value.
2. Measurement Level = Reading Level + LISN Factor + Cable loss.
3. "--", means the average measurement was not performed when the Quasi-peak measured data under the limit of average detection.

QUIETEK CORPORATION  
EMI TEST RECEIVER RSCS30

EUT: P4B533-E WITH CRW-4816A  
Operator: TONY  
Test Spec: AC 230V/50Hz  
Comment: LINE 1  
MODE 1  
File name: CISPR22B.SPC  
Date: 25. Apr 02 22:21

Overview Scan Settings (1 Range)

Frequencies			Receiver Settings					
Start	Stop	Step	IF BW	Detector	M-Time	Atten	Preamp	
150k	30M	3.9k	9k	PK	0.05ms	0dB	OFF	

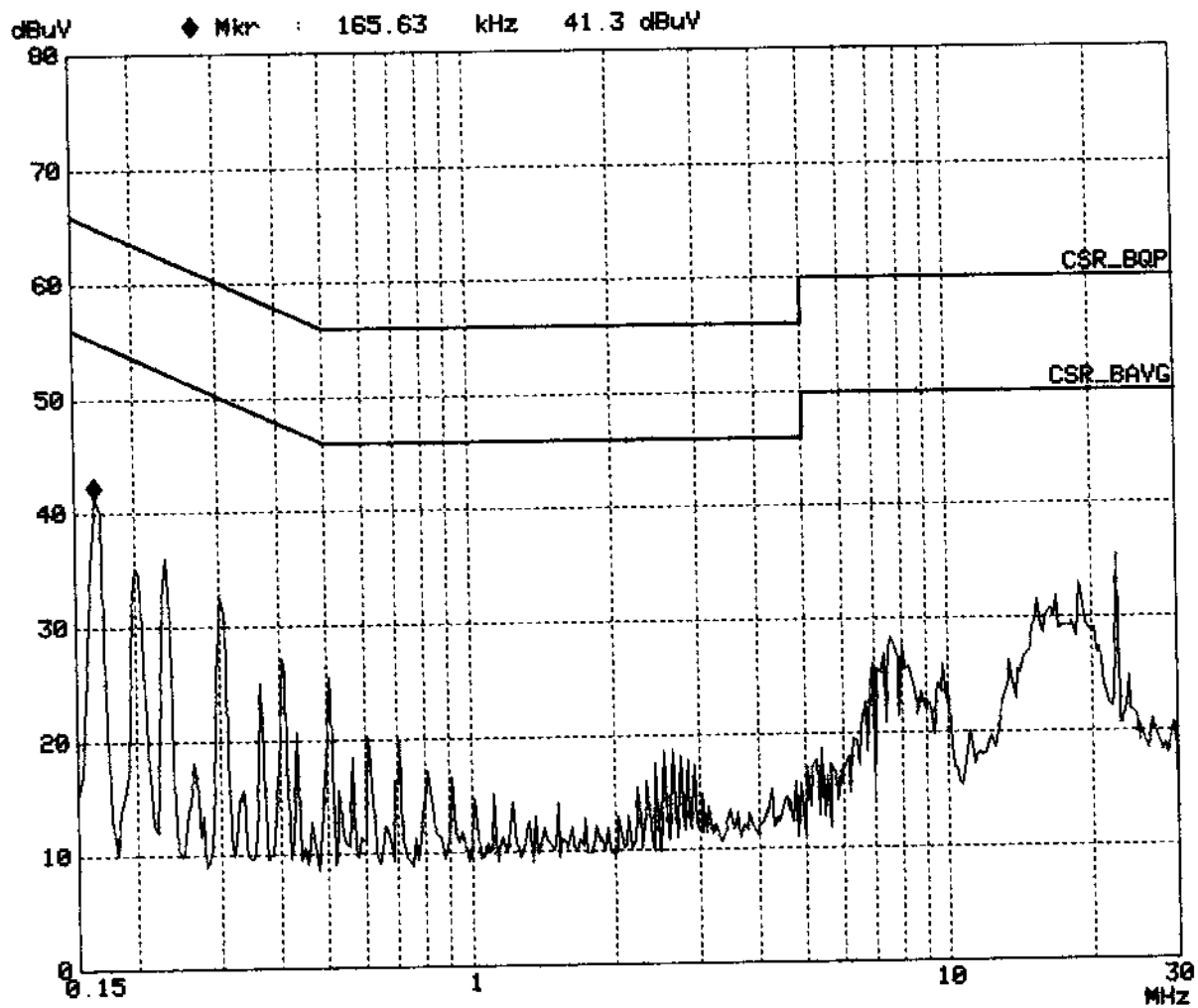

QUIETEK CORPORATION  
EMI TEST RECEIVER RSCS30

EUT: P4B533-E WITH CRW-4816A  
Operator: TONY  
Test Spec: AC 230V/50Hz  
Comment: LINE 2  
MODE 1  
File name: CISPR22B.SPC  
Date: 25. Apr 02 22:25

Overview Scan Settings (1 Range)

Frequencies			Receiver Settings				
Start	Stop	Step	IF BW	Detector	M-Time	Atten	Preamp
150k	30M	3.9k	9k	PK	0.05ms	0dBLN	OFF

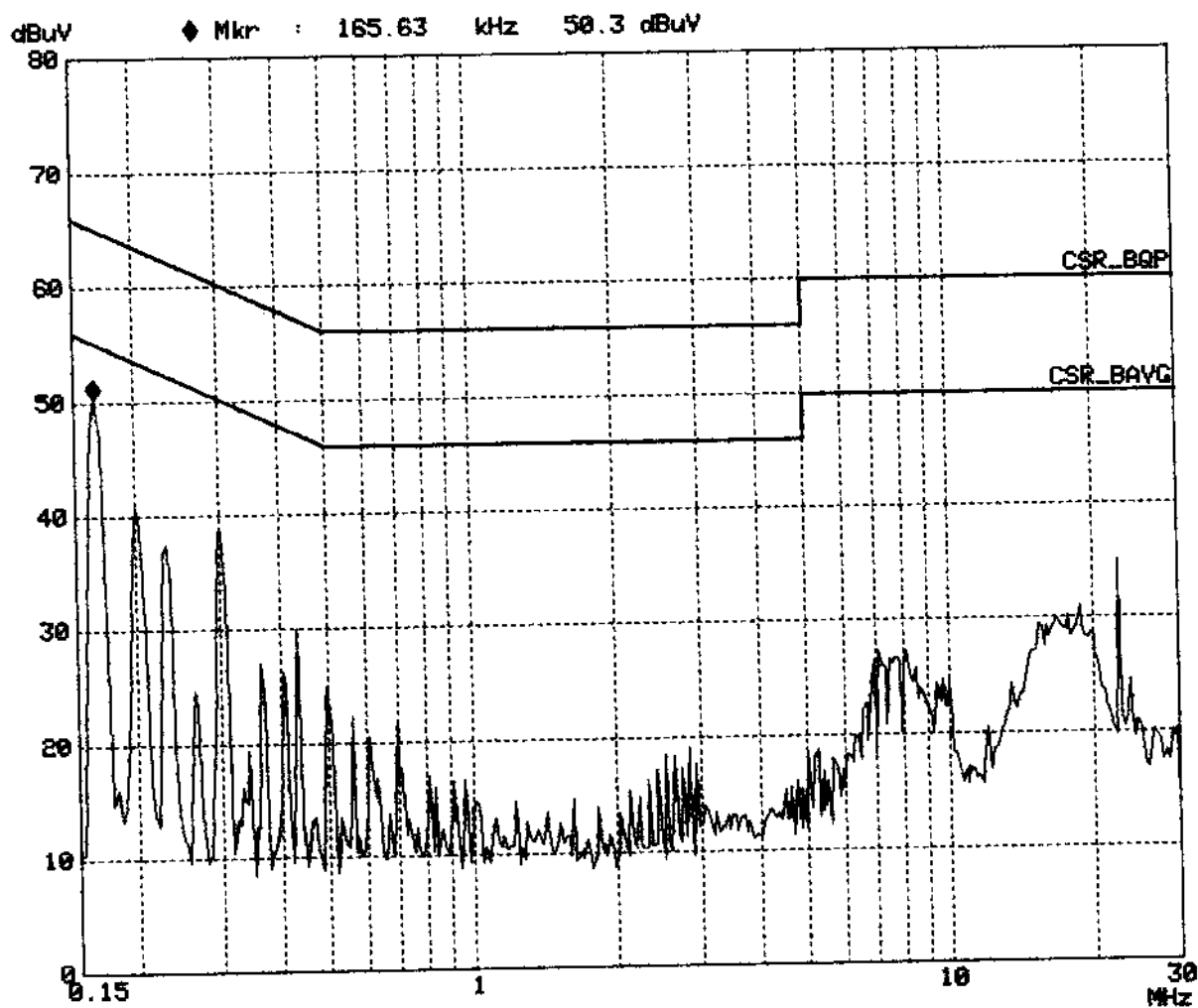

Date of Test	April 29, 2002	Test Room	No.4 Shielded Room
Test Mode	Mode 2: P4 2.2GHz/100MHz+Read Mode	Product	Mother Board with CD-RW
Test Condition	Line1 & Line2	Test Range	0.15MHz – 30MHz

Frequency MHz	Measurement Level (dBuV)				Limits (dBuV)	
	Line1 QP	Line1 AV	Line2 QP	Line2 AV	QP	AV
0.166	42.72	39.81	--	--	65.18	55.18
0.166	--	--	49.67	46.01	65.18	55.18
0.201	--	--	40.06	38.01	63.58	53.58
0.232	36.01	33.41	--	--	62.38	52.38
0.298	--	--	37.36	33.11	60.29	50.29
0.302	33.06	30.51	--	--	60.18	50.18
0.404	27.25	26.81	--	--	57.77	47.77
0.431	--	--	29.21	25.21	57.23	47.23
7.603	--	--	27.21	26.22	60.00	50.00
7.861	26.10	25.42	--	--	60.00	50.00
18.806	32.13	28.07	--	--	60.00	50.00
22.568	--	--	34.88	31.65	60.00	50.00

Note:

1. All Reading Levels are Quasi-Peak and average value.
2. Measurement Level = Reading Level + LISN Factor + Cable loss.
3. "--", means the average measurement was not performed when the Quasi-peak measured data under the limit of average detection.

QUIETEK CORPORATION  
EMI TEST RECEIVER RSCS30

EUT: P4B533-E WITH CRW-4816A  
 Operator: TONY  
 Test Spec: AC 230V/50Hz  
 Comment: LINE 1  
 MODE 2  
 File name: CISPR22B.SPC  
 Date: 25. Apr 02 22:35

Overview Scan Settings (1 Range)

Frequencies			Receiver Settings					
Start	Stop	Step	IF BW	Detector	M-Time	Atten	Preamp	
150k	30M	3.9k	9k	PK	0.10ms	0dB	BLN OFF	

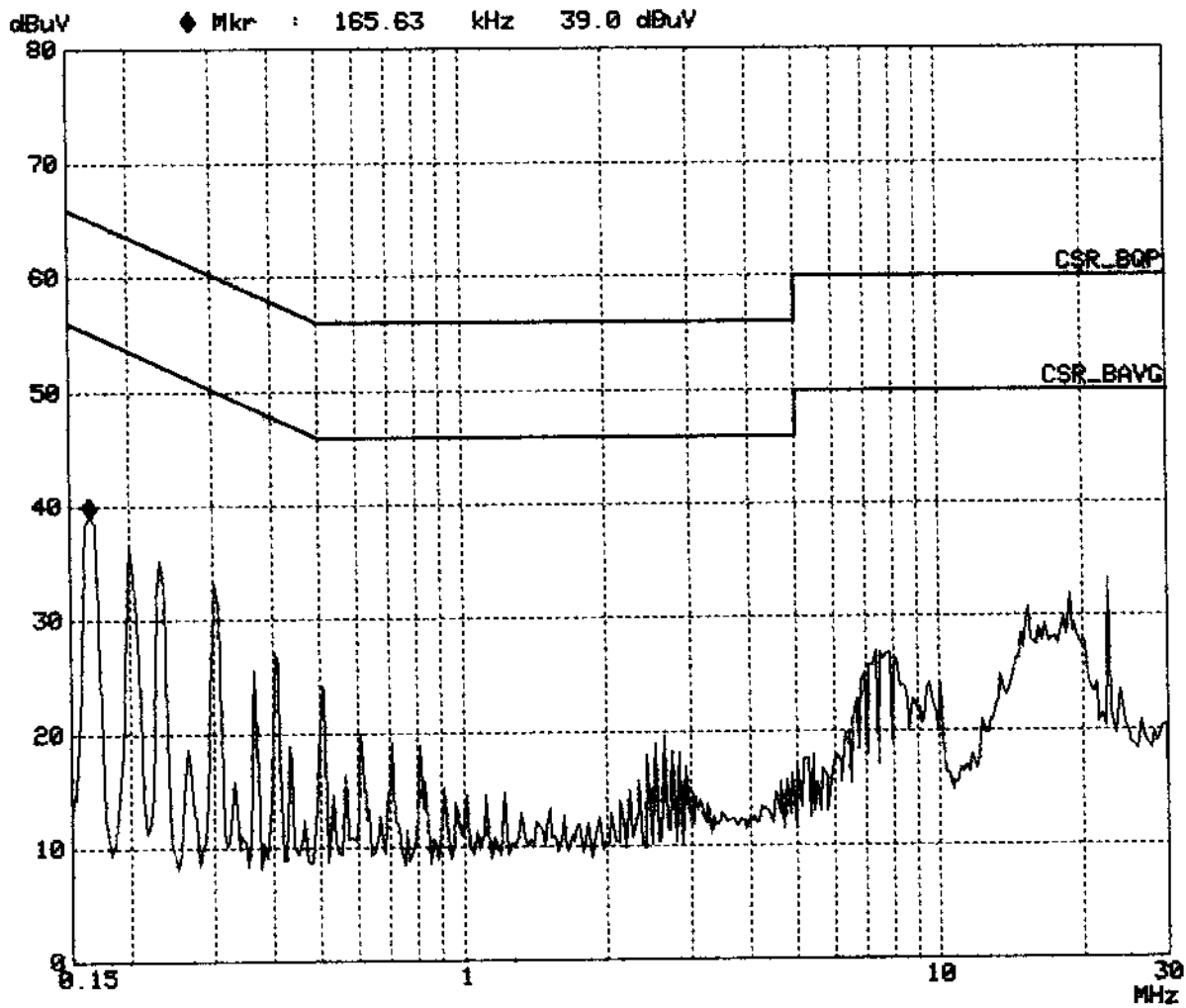

QUIETEK CORPORATION  
EMI TEST RECEIVER RSCS30

EUT: P4B533-E WITH CRW-4816A  
Operator: TONY  
Test Spec: AC 230V/50Hz  
Comment: LINE 2  
MODE 2  
File name: CISPR22B.SPC  
Date: 25. Apr 02 22:39

Overview Scan Settings (1 Range)

Frequencies			Receiver Settings				
Start	Stop	Step	IF BW	Detector	M-Time	Atten	Preamp
150k	30M	3.9k	9k	PK	0.10ms	0dB	BLN OFF

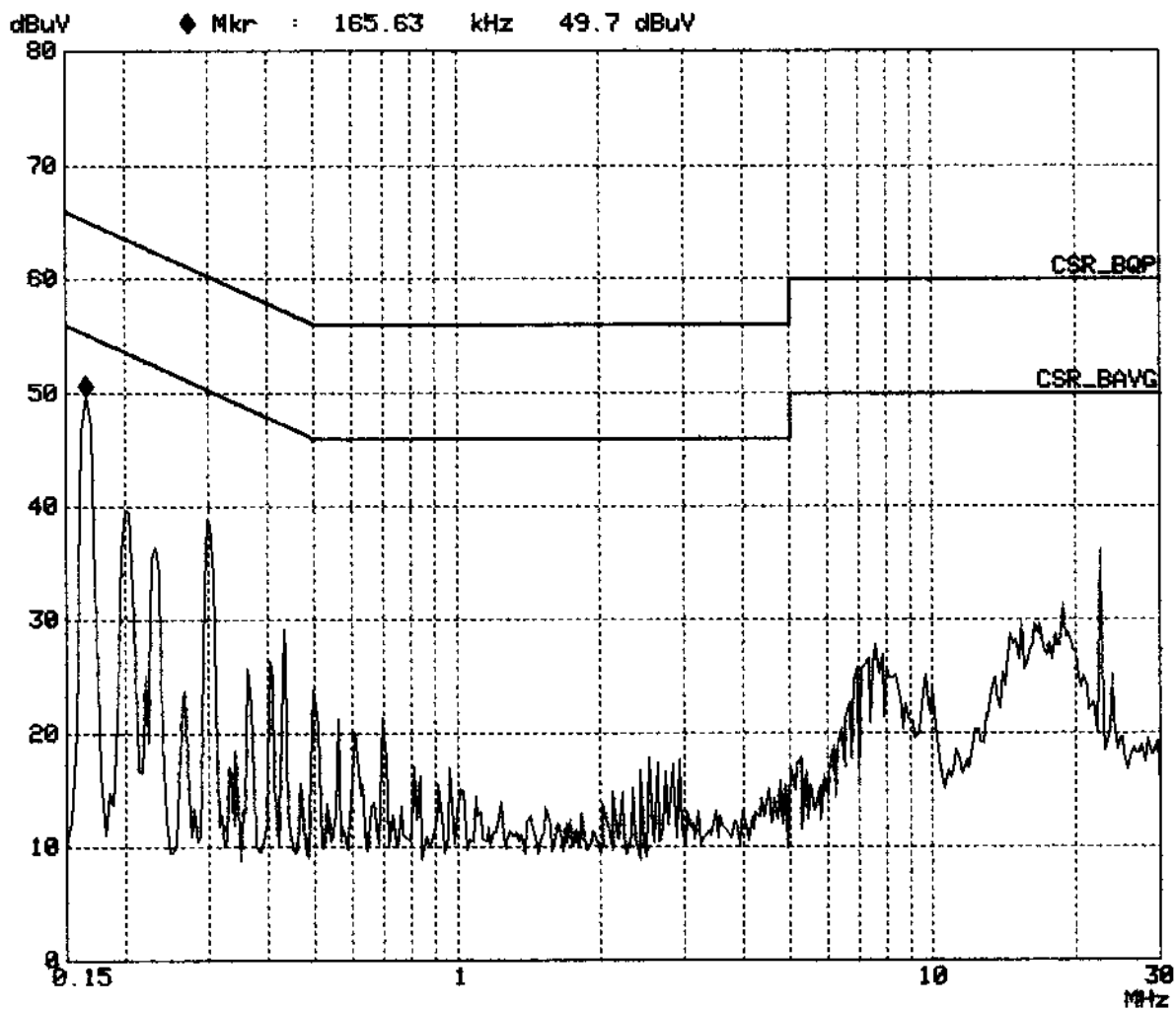



**13.2. Test Data of Radiated Emission**

Date of Test	April 29, 2002	Test Site	No.1 OATS
Test Mode	Mode 1: P4 2.4GHz/133MHz+R/W Mode	Product	Mother Board with CD-RW
Test Condition	10m & Horizontal	Test Range	30MHz – 1GHz

Frequency MHz	Cable Loss (dB)	Probe Factor (dB/m)	Pre-Amp Factor (dB)	Reading Level (dBuV/m)	Emission Level (dBuV/m)	Margin (dB)	Limit (dBuV/m)
138.275	1.43	11.29	0.00	12.41	25.13	-4.87	30
150.876	1.49	10.40	0.00	12.46	24.35	-5.65	30
168.540	1.59	8.96	0.00	16.43	26.98	-3.02	30
196.608	1.73	8.20	0.00	14.61	24.54	-5.46	30
222.217	1.86	8.63	0.00	12.86	23.35	-6.65	30
235.667	1.93	10.05	0.00	19.21	31.19	-5.81	37
269.600	2.10	12.00	0.00	12.21	26.31	-10.69	37
336.060	2.45	12.68	0.00	13.35	28.48	-8.52	37
369.965	2.62	13.91	0.00	16.16	32.69	-4.31	37
471.020	3.14	16.70	0.00	13.93	33.77	-3.23	37
504.880	3.32	16.49	0.00	12.69	32.50	-4.50	37
605.740	3.84	17.89	0.00	8.88	30.61	-6.39	37

Note:

1. All Reading Levels below 1GHz are Quasi-Peak.
2. Emission Level = Reading Level + Probe Factor + Cable loss – Preamp.
3. Margin = Limit - Emission Level

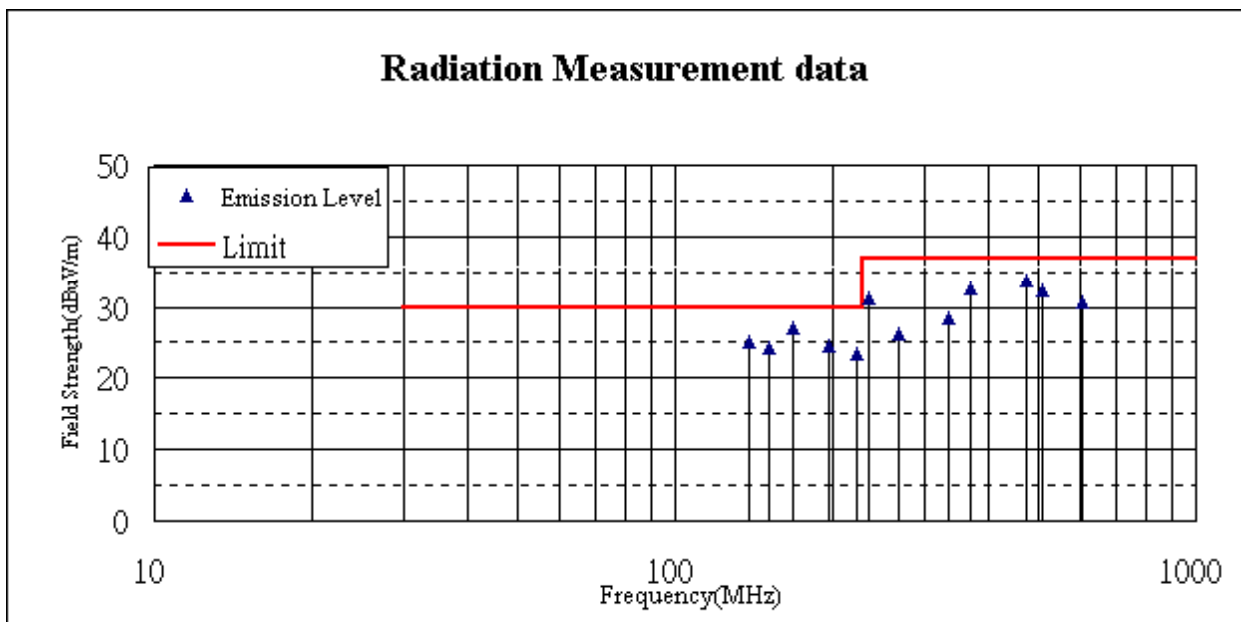

Date of Test	April 29, 2002	Test Site	No.1 OATS
Test Mode	Mode 1: P4 2.4GHz/133MHz+R/W Mode	Product	Mother Board with CD-RW
Test Condition	10m & Vertical	Test Range	30MHz – 1GHz

Frequency MHz	Cable Loss (dB)	Probe Factor (dB/m)	Pre-Amp Factor (dB)	Reading Level (dBuV/m)	Emission Level (dBuV/m)	Margin (dB)	Limit (dBuV/m)
48.046	0.96	7.00	0.00	18.75	26.71	-3.29	30
80.005	1.12	7.22	0.00	15.32	23.66	-6.34	30
114.249	1.31	10.85	0.00	12.39	24.55	-5.45	30
138.275	1.43	10.30	0.00	12.41	24.14	-5.86	30
150.006	1.49	9.13	0.00	15.33	25.95	-4.05	30
168.260	1.59	8.52	0.00	12.79	22.90	-7.10	30
179.995	1.64	8.41	0.00	10.42	20.47	-9.53	30
200.006	1.74	8.40	0.00	15.56	25.70	-4.30	30
235.750	1.93	10.35	0.00	20.18	32.46	-4.54	37
336.055	2.45	12.63	0.00	17.54	32.62	-4.38	37
384.065	2.70	15.08	0.00	14.46	32.24	-4.76	37
471.350	3.15	16.50	0.00	13.51	33.16	-3.84	37

Note:

1. All Reading Levels below 1GHz are Quasi-Peak.
2. Emission Level = Reading Level + Probe Factor + Cable loss – Preamp.
3. Margin = Limit - Emission Level

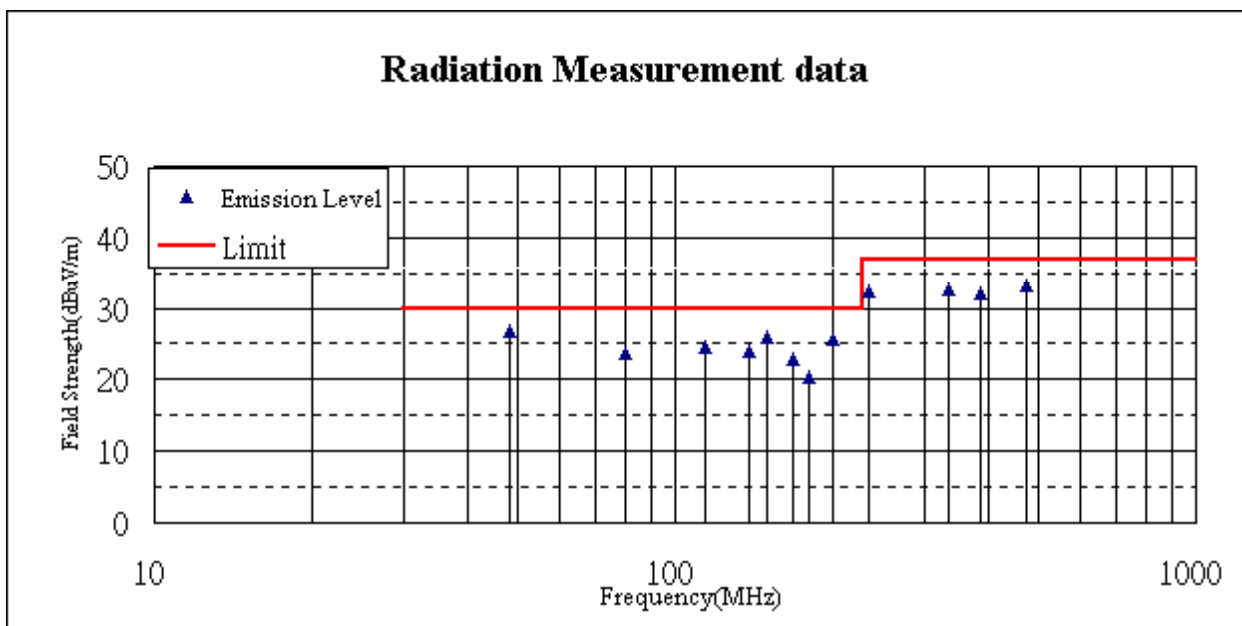

Date of Test	April 29, 2002	Test Site	No.1 OATS
Test Mode	Mode 2: P4 2.2GHz/100MHz+Read Mode	Product	Mother Board with CD-RW
Test Condition	10m & Horizontal	Test Range	30MHz – 1GHz

Frequency MHz	Cable Loss (dB)	Probe Factor (dB/m)	Pre-Amp Factor (dB)	Reading Level (dBuV/m)	Emission Level (dBuV/m)	Margin (dB)	Limit (dBuV/m)
112.506	1.29	12.01	0.00	13.11	26.41	-3.59	30
138.716	1.43	11.29	0.00	11.32	24.04	-5.96	30
150.001	1.49	10.32	0.00	12.25	24.06	-5.94	30
196.610	1.73	8.20	0.00	14.97	24.90	-5.10	30
235.750	1.93	10.05	0.00	18.37	30.35	-6.65	37
336.055	2.45	12.68	0.00	18.80	33.93	-3.07	37
432.078	2.95	15.81	0.00	14.80	33.56	-3.44	37
500.020	3.30	16.34	0.00	12.44	32.08	-4.92	37
887.722	5.30	19.92	0.00	4.84	30.06	-6.94	37

Note:

1. All Reading Levels below 1GHz are Quasi-Peak.
2. Emission Level = Reading Level + Probe Factor + Cable loss – Preamp.
3. Margin = Limit - Emission Level

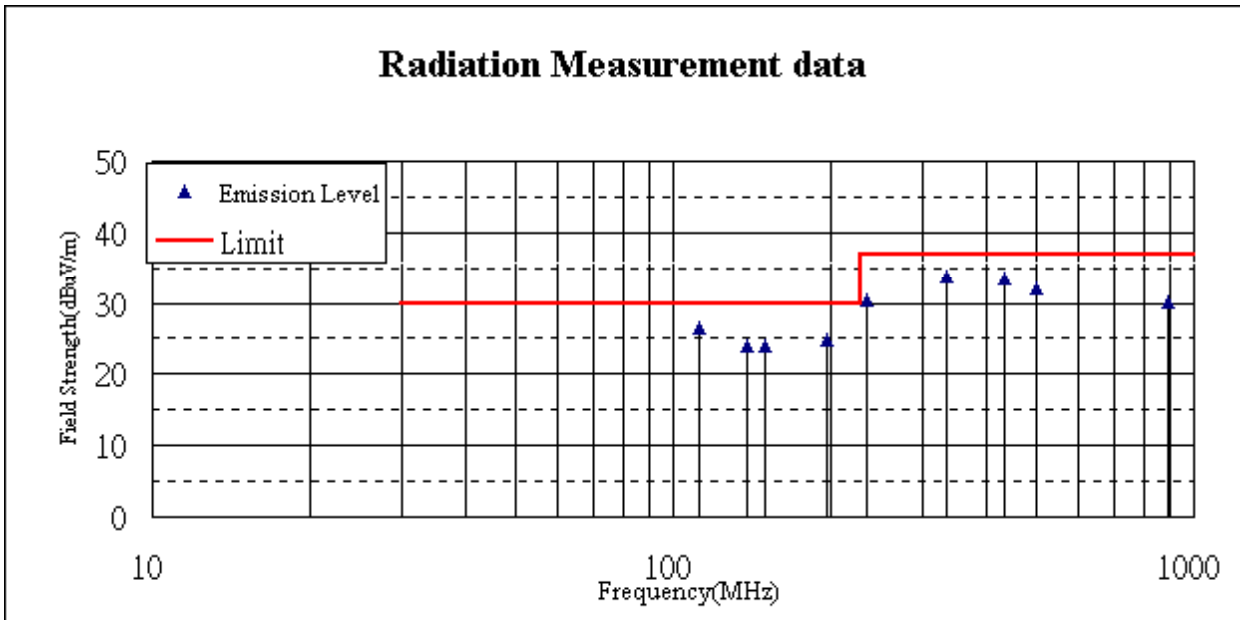

Date of Test	April 29, 2002	Test Site	No.1 OATS
Test Mode	Mode 2: P4 2.2GHz/100MHz+Read Mode	Product	Mother Board with CD-RW
Test Condition	10m & Vertical	Test Range	30MHz – 1GHz

Frequency MHz	Cable Loss (dB)	Probe Factor (dB/m)	Pre-Amp Factor (dB)	Reading Level (dBuV/m)	Emission Level (dBuV/m)	Margin (dB)	Limit (dBuV/m)
52.130	0.99	6.39	0.00	19.58	26.96	3.04	30
112.502	1.29	10.92	0.00	13.66	25.87	4.13	30
138.497	1.43	10.30	0.00	12.75	24.48	5.52	30
150.005	1.49	9.13	0.00	14.76	25.38	4.62	30
168.220	1.59	8.52	0.00	15.61	25.72	4.28	30
196.613	1.73	8.14	0.00	12.76	22.63	7.37	30
240.041	1.96	10.82	0.00	14.10	26.88	10.12	37
336.057	2.45	12.63	0.00	18.67	33.75	3.25	37
500.022	3.30	16.34	0.00	8.03	27.67	9.33	37

Note:

1. All Reading Levels below 1GHz are Quasi-Peak.
2. Emission Level = Reading Level + Probe Factor + Cable loss – Preamp.
3. Margin = Limit - Emission Level

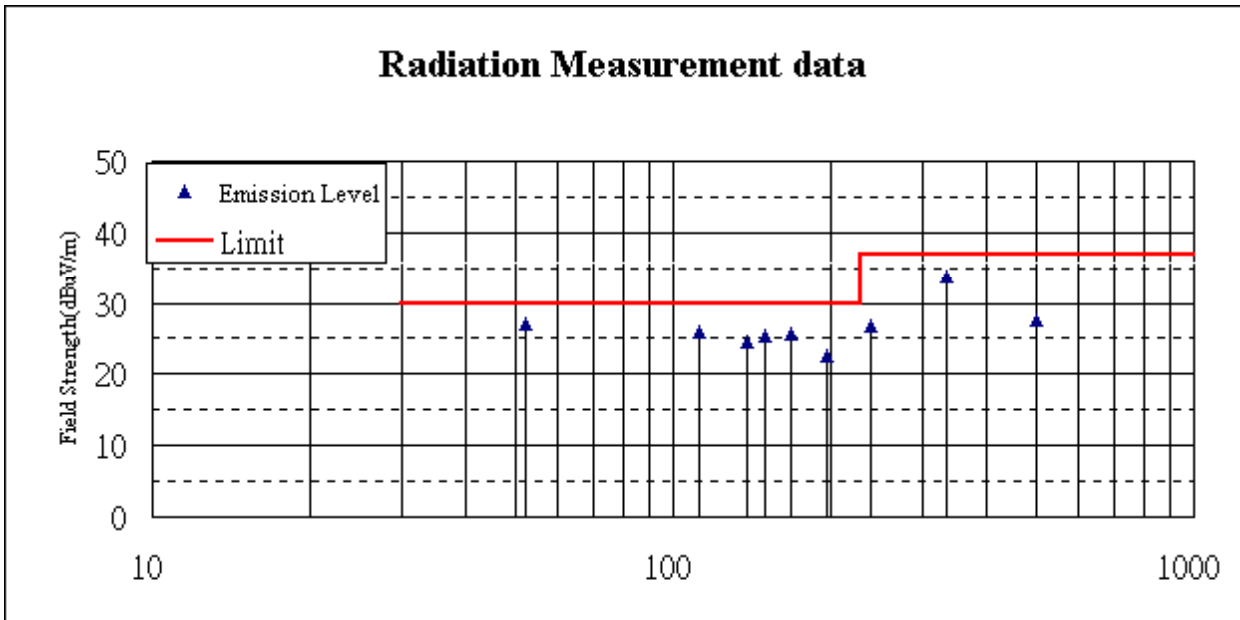

### 13.3. Test Data of Power Harmonics

Date of Test	April 29, 2002	Test Room	No.3 Shielded Room
Test Mode	Mode 1: P4 2.4GHz/133MHz+R/W Mode	Product	Mother Board with CD-RW
Test Condition	Power Harmonics (Classification: Class D)		

Test Result: Pass

Source qualification: Normal

Current & voltage waveforms

It is 1.6% outside Class-D envelope

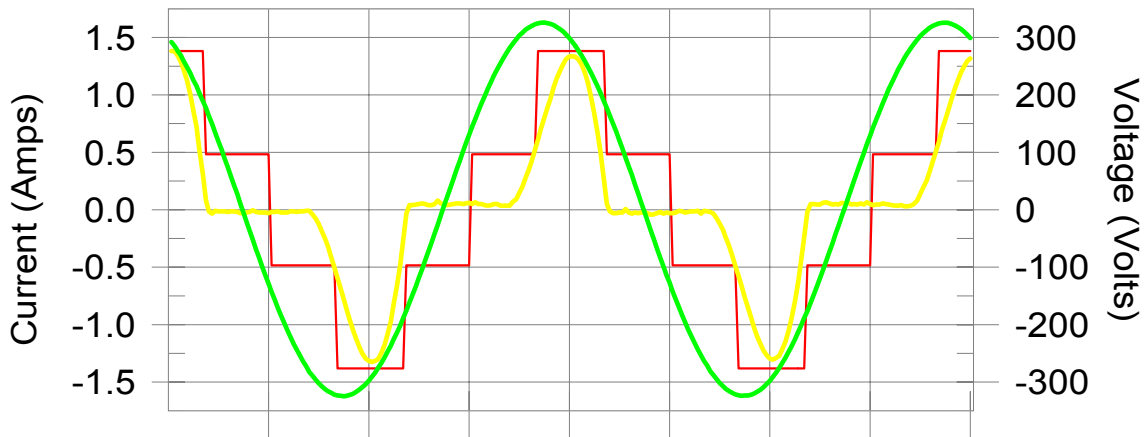

Harmonics and Class D limit line

European Limits

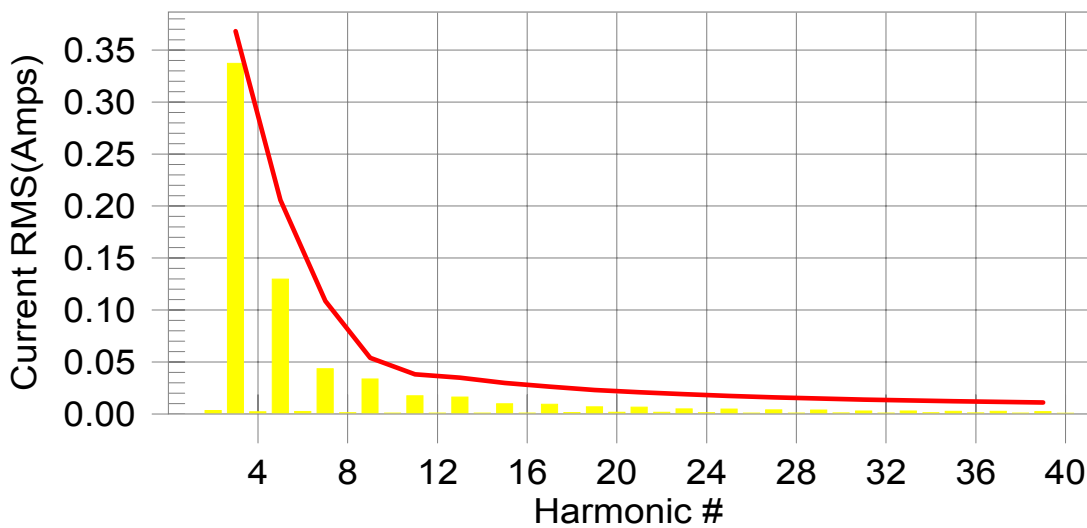

Test result: Pass

Worst harmonic was #3 with 91.57 % of the limit.

Test Result: Pass

Source qualification: Normal

Highest parameter values during test:

V_RMS (Volts):	229.86	I_RMS (Amps):	0.617
I_Peak (Amps):	1.381	Crest Factor:	2.267
I_Fund (Amps):	0.505	Power Factor:	0.778
Power (Watts):	110		

Harm#	Harmonics	Limit	% of Limit	Status
2	0.003			
3	0.337	0.368	91.57	Pass
4	0.002			
5	0.130	0.206	63.03	Pass
6	0.002			
7	0.043	0.109	40.00	Pass
8	0.001			
9	0.034	0.054	62.13	Pass
10	0.001			
11	0.017	0.038	45.82	Pass
12	0.001			
13	0.016	0.035	46.78	Pass
14	0.001			
15	0.010	0.030	32.84	Pass
16	0.001			
17	0.009	0.026	35.58	Pass
18	0.001			
19	0.007	0.023	29.80	Pass
20	0.002			
21	0.007	0.021	31.76	Pass
22	0.002			
23	0.005	0.019	0.00	Pass
24	0.001			
25	0.005	0.017	0.00	Pass
26	0.001			
27	0.004	0.016	0.00	Pass
28	0.001			
29	0.004	0.015	0.00	Pass
30	0.001			
31	0.003	0.014	0.00	Pass
32	0.001			
33	0.003	0.013	0.00	Pass
34	0.001			
35	0.003	0.012	0.00	Pass
36	0.001			
37	0.003	0.012	0.00	Pass
38	0.001			
39	0.002	0.011	0.00	Pass
40	0.001			

Note:

1. Dynamic limits were applied for this test. The highest harmonics values in the above table may not occur at the same window as the maximum harmonics/limit ratio.

2. According to EN61000-3-2 paragraph 7.4 the limits given in table 3 are valid for all applications having an active input power >75W.

3. -- " mean the limit is not applicable

Date of Test	April 29, 2002	Test Room	No.3 Shielded Room
Test Mode	Mode 1: P4 2.4GHz/133MHz+R/W Mode	Product	Mother Board with CD-RW
Test Condition	Voltage Fluctuations and Flicker		

Test Result: Pass

Status: Test Completed

Pst<sub>i</sub> and limit line

European Limits

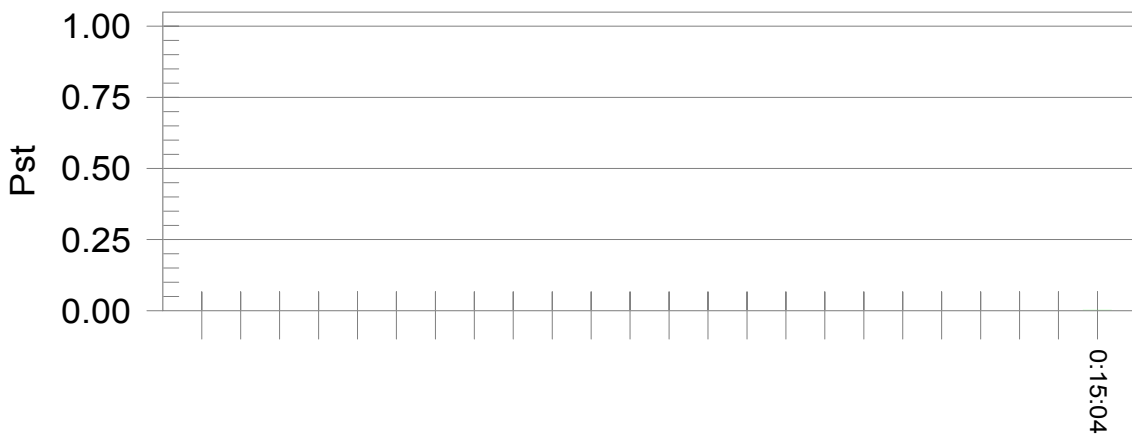

Time is too short for Plt plot

Parameter values recorded during the test:

Vrms at the end of test (Volt):	229.80		
Highest dt (%):	0.00	Test limit (%):	4.00
Highest dc (%):	0.00	Test limit (%):	3.30
Highest dmax (%):	0.00	Test limit (%):	4.00
Highest Pst (10 min. period):	0.001	Test limit:	1.000
Highest Plt (2 hr. period):	0.001	Test limit:	0.650

Date of Test	April 29, 2002	Test Room	No.3 Shielded Room
Test Mode	Mode 2: P4 2.2GHz/100MHz+Read Mode	Product	Mother Board with CD-RW
Test Condition	Power Harmonics (Classification: Class D)		

Test Result: Pass

Source qualification: Normal

Current & voltage waveforms

It is 1.6% outside Class-D envelope

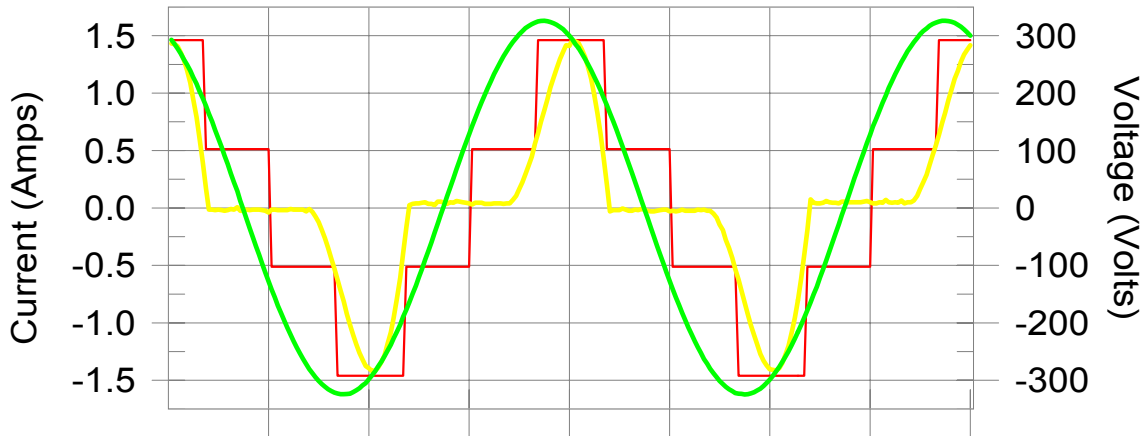

Harmonics and Class D limit line

European Limits

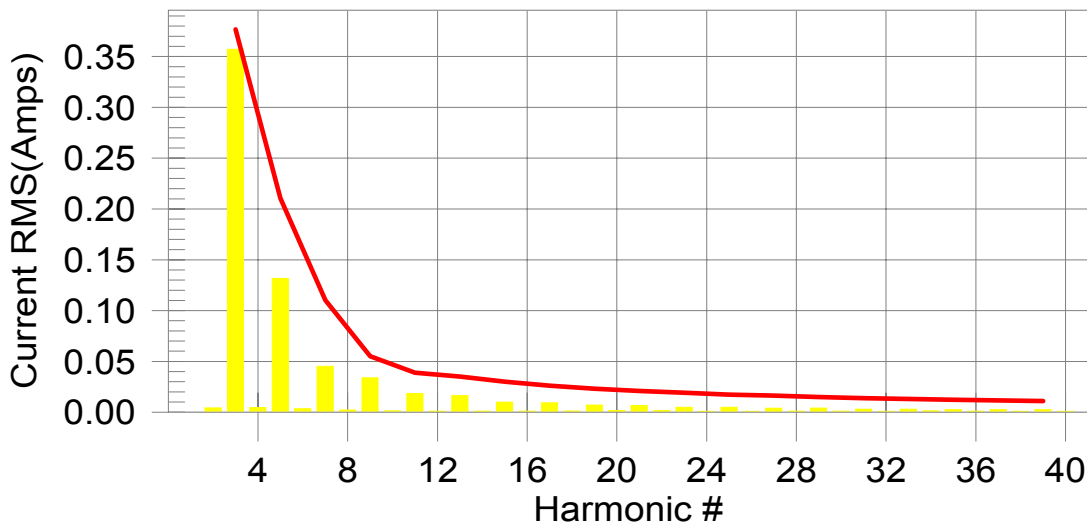

Test result: Pass

Worst harmonic was #3 with 94.79 % of the limit.



Test Result: Pass

Source qualification: Normal

Highest parameter values during test:

V_RMS (Volts):	229.85	I_RMS (Amps):	0.620
I_Peak (Amps):	1.461	Crest Factor:	2.355
I_Fund (Amps):	0.548	Power Factor:	0.778
Power (Watts):	111		

Harm#	Harmonics	Limit	% of Limit	Status
2	0.004			
3	0.357	0.377	94.79	Pass
4	0.005			
5	0.132	0.211	62.48	Pass
6	0.003			
7	0.045	0.110	41.06	Pass
8	0.002			
9	0.034	0.055	61.42	Pass
10	0.001			
11	0.018	0.039	47.19	Pass
12	0.001			
13	0.016	0.035	46.45	Pass
14	0.001			
15	0.010	0.030	33.31	Pass
16	0.001			
17	0.009	0.026	35.61	Pass
18	0.001			
19	0.007	0.023	29.95	Pass
20	0.002			
21	0.007	0.021	31.68	Pass
22	0.002			
23	0.005	0.019	0.00	Pass
24	0.001			
25	0.005	0.017	0.00	Pass
26	0.001			
27	0.004	0.016	0.00	Pass
28	0.001			
29	0.004	0.015	0.00	Pass
30	0.001			
31	0.003	0.014	0.00	Pass
32	0.001			
33	0.003	0.013	0.00	Pass
34	0.001			
35	0.002	0.012	0.00	Pass
36	0.001			
37	0.003	0.012	0.00	Pass
38	0.001			
39	0.002	0.011	0.00	Pass
40	0.001			

Note:

1. Dynamic limits were applied for this test. The highest harmonics values in the above table may not occur at the same window as the maximum harmonics/limit ratio.
2. According to EN61000-3-2 paragraph 7.4 the limits given in table 3 are valid for all applications having an active input power >75W.
3. -- " mean the limit is not applicable

Date of Test	April 29, 2002	Test Room	No.3 Shielded Room
Test Mode	Mode 2: P4 2.2GHz/100MHz+Read Mode	Product	Mother Board with CD-RW
Test Condition	Voltage Fluctuations and Flicker		

Test Result: Pass

Status: Test Completed

Pstj and limit line

European Limits

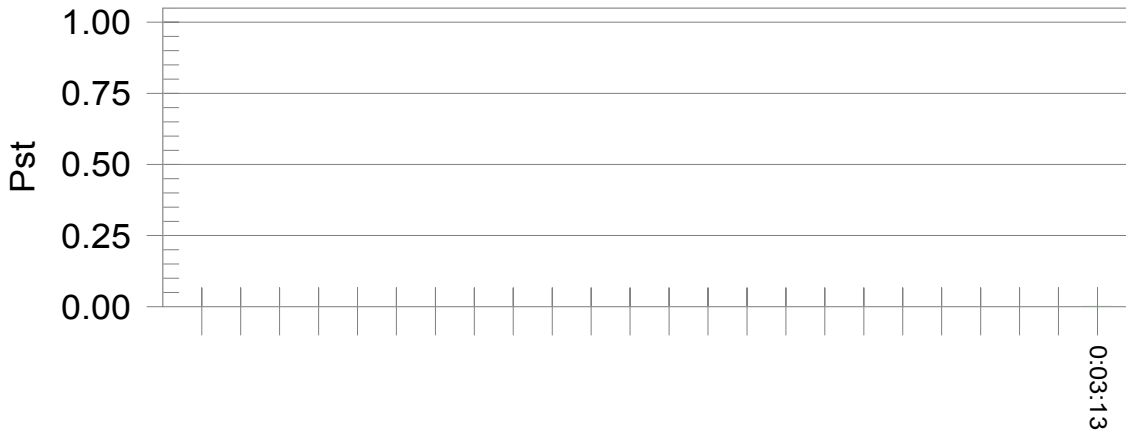

Time is too short for Plt plot

Parameter values recorded during the test:

Vrms at the end of test (Volt):	229.82		
Highest dt (%):	0.00	Test limit (%):	4.00
Highest dc (%):	0.00	Test limit (%):	3.30
Highest dmax (%):	0.00	Test limit (%):	4.00
Highest Pst (10 min. period):	0.001	Test limit:	1.000
Highest Plt (2 hr. period):	0.001	Test limit:	0.650

### 13.4. Test Data of Electrostatic Discharge

Date of Test	April 29, 2002	Test Room	No.3 Shielded Room
Test Mode	Mode 1: P4 2.4GHz/133MHz+R/W Mode	Product	Mother Board with CD-RW
Test Condition	Electrostatic Discharge (Performance Criteria: B)		

Test point	Polarity	Number of Discharges	Complied To Criteria (A,B,C)	Result
Seams	+/-8kV Air	10	B	<b>PASS</b>
Switch	+/-8kV Air	10	B	<b>PASS</b>
Knobs	+/-4kV Con	50	B	<b>PASS</b>
Metal Plate	+/-4kV Con	50	B	<b>PASS</b>
Screws	+/-4kV Con	50	B	<b>PASS</b>
H.C.P.	+/-4kV	50	B	<b>PASS</b>
V.C.P.	+/-4kV	50	B	<b>PASS</b>

#### Criteria judgment of Test result:

- Meet criteria A: No abnormalities were observed during and directly after the test.
- Meet criteria B: Operate as intended after the test
- Meet criteria C: Loss/Error of function
- Additional Information
  - EUT stopped operation and could / could not be reset by operator at \_\_\_\_ kV.
  - No false alarms or other malfunctions were observed during or after the test.

### 13.5. Test Data of Radiated Susceptibility

Date of Test	April 29, 2002	Test Room	No.3 Shielded Room
Test Mode	Mode 1: P4 2.4GHz/133MHz+R/W Mode	Product	Mother Board with CD-RW
Test Condition	Radiated Susceptibility (Performance Criteria: A)		

Frequency (MHz)	Position (Angle)	Polarity (H or V)	Field Strength (V/m)	Complied To Criteria (A,B,C)	Results
80-1000	0	H	3	A	<b>Pass</b>
80-1000	0	V	3	A	<b>Pass</b>
80-1000	90	H	3	A	<b>Pass</b>
80-1000	90	V	3	A	<b>Pass</b>
80-1000	180	H	3	A	<b>Pass</b>
80-1000	180	V	3	A	<b>Pass</b>
80-1000	270	H	3	A	<b>Pass</b>
80-1000	270	V	3	A	<b>Pass</b>

#### Criteria judgment of Test result:

- Meet criteria A: No abnormalities were observed during and directly after the test.
- Meet criteria B: Operate as intended after the test
- Meet criteria C: Loss/Error of function
- Additional Information
  - EUT stopped operation and could / could not be reset by operator at \_\_\_\_ kV.
  - No false alarms or other malfunctions were observed during or after the test.

**13.6. Test Data of Electrical Fast Transient**

Date of Test	April 29, 2002	Test Room	No.3 Shielded Room
Test Mode	Mode 1: P4 2.4GHz/133MHz+R/W Mode	Product	Mother Board with CD-RW
Test Condition	Electrical Fast Transient (Performance Criteria: A)		

Inject Line	Polarity	Voltage kV	Inject Time (Second)	Inject Method	Complied To Criteria (A,B,C)	Result
L	±	1kV	60	Direct	A	<b>Pass</b>
N	±	1kV	60	Direct	A	<b>Pass</b>
PE	±	1kV	60	Direct	A	<b>Pass</b>
L+N	±	1kV	60	Direct	A	<b>Pass</b>
L+PE	±	1kV	60	Direct	A	<b>Pass</b>
N+PE	±	1kV	60	Direct	A	<b>Pass</b>
L+N+PE	±	1kV	60	Direct	A	<b>Pass</b>
LAN	±	0.5kV	60	CLAMP	A	<b>Pass</b>

**Criteria judgment of Test result:**

- Meet criteria A: No abnormalities were observed during and directly after the test.
- Meet criteria B: Operate as intended after the test
- Meet criteria C: Loss/Error of function
- Additional Information
  - EUT stopped operation and could / could not be reset by operator at \_\_\_\_ kV.
  - No false alarms or other malfunctions were observed during or after the test.

**13.7. Test Data of Surge**

Date of Test	April 29, 2002	Test Room	No.3 Shielded Room
Test Mode	Mode 1: P4 2.4GHz/133MHz+R/W Mode	Product	Mother Board with CD-RW
Test Condition	Surge (Performance Criteria: A)		

Inject Line	Polarity	Angle	Voltage kV	Time Interval (Second)	Inject Method	Complied To Criteria (A,B,C)	Result
L-N	±	0	1kV	60	Direct	B	<b>Pass</b>
L-N	±	90	1kV	60	Direct	B	<b>Pass</b>
L-N	±	180	1kV	60	Direct	B	<b>Pass</b>
L-N	±	270	1kV	60	Direct	B	<b>Pass</b>
L-PE	±	0	2kV	60	Direct	B	<b>Pass</b>
L-PE	±	90	2kV	60	Direct	B	<b>Pass</b>
L-PE	±	180	2kV	60	Direct	B	<b>Pass</b>
L-PE	±	270	2kV	60	Direct	B	<b>Pass</b>
N-PE	±	0	2kV	60	Direct	B	<b>Pass</b>
N-PE	±	90	2kV	60	Direct	B	<b>Pass</b>
N-PE	±	180	2kV	60	Direct	B	<b>Pass</b>
N-PE	±	270	2kV	60	Direct	B	<b>Pass</b>

**Criteria judgment of Test result:**

- Meet criteria A: No abnormalities were observed during and directly after the test.
- Meet criteria B: Operate as intended after the test
- Meet criteria C: Loss/Error of function
- Additional Information
  - EUT stopped operation and could / could not be reset by operator at \_\_\_\_ kV.
  - No false alarms or other malfunctions were observed during or after the test.

**13.8. Test Data of Conducted Susceptibility**

Date of Test	April 29, 2002	Test Room	No.3 Shielded Room
Test Mode	Mode 1: P4 2.4GHz/133MHz+R/W Mode	Product	Mother Board with CD-RW
Test Condition	Conducted Susceptibility (Performance Criteria: A)		

Frequency Range (MHz)	Voltage Applied dBuV(V)	Inject Method	Tested Port of EUT	Complied To Criteria (A,B,C)	Result
0.15 ~ 80	130(3V)	CDN 1	AC IN	A	<b>PASS</b>
0.15 ~ 80	130(3V)	Clamp	Lan Cable	A	<b>PASS</b>

Criteria judgment of Test result:

- Meet criteria A: No abnormalities were observed during and directly after the test.
- Meet criteria B: Operate as intended after the test
- Meet criteria C: Loss/Error of function
- Additional Information
  - EUT stopped operation and could / could not be reset by operator at \_\_\_\_ kV.
  - No false alarms or other malfunctions were observed during or after the test.

**13.9. Test Data of Power Frequency Magnetic Field**

Date of Test	April 29, 2002	Test Room	No.3 Shielded Room
Test Mode	Mode 1: P4 2.4GHz/133MHz+R/W Mode	Product	Mother Board with CD-RW
Test Condition	Power Frequency Magnetic Field (Performance criteria: A)		

Polarization	Frequency (Hz)	Magnetic Strength (A/m)	Complied To Criteria (A,B,C)	Test Result
X Orientation	50	1	A	<b>PASS</b>
Y Orientation	50	1	A	<b>PASS</b>
Z Orientation	50	1	A	<b>PASS</b>

Criteria judgment of Test result:

- Meet criteria A: No abnormalities were observed during and directly after the test.
- Meet criteria B: Operate as intended after the test
- Meet criteria C: Loss/Error of function
- Additional Information
  - EUT stopped operation and could / could not be reset by operator at \_\_\_\_ kV.
  - No false alarms or other malfunctions were observed during or after the test.



### 13.10. Test Data of Voltage Dips and Interruption

Date of Test	April 29, 2002	Test Room	No.3 Shielded Room
Test Mode	Mode 1: P4 2.4GHz/133MHz+R/W Mode	Product	Mother Board with CD-RW
Test Condition	Voltage Dips and Interruption		

Voltage Dips and Interruption Reduction(%)	Angle	Test Duration (Periods)	Required Performance Criteria	Complied To Criteria (A,B,C)	Test Result
>95(0V)	0	0.5	B	A	PASS
>95(0V)	45	0.5	B	A	PASS
>95(0V)	90	0.5	B	A	PASS
>95(0V)	135	0.5	B	A	PASS
>95(0V)	180	0.5	B	A	PASS
>95(0V)	225	0.5	B	A	PASS
>95(0V)	270	0.5	B	A	PASS
>95(0V)	315	0.5	B	A	PASS
30(161V)	0	25	C	A	PASS
30(161V)	45	25	C	A	PASS
30(161V)	90	25	C	A	PASS
30(161V)	135	25	C	A	PASS
30(161V)	180	25	C	A	PASS
30(161V)	225	25	C	A	PASS
30(161V)	270	25	C	A	PASS
30(161V)	315	25	C	A	PASS
>95(0V)	0	250	C	C	PASS
>95(0V)	45	250	C	C	PASS
>95(0V)	90	250	C	C	PASS
>95(0V)	135	250	C	C	PASS
>95(0V)	180	250	C	C	PASS
>95(0V)	225	250	C	C	PASS
>95(0V)	270	250	C	C	PASS
>95(0V)	315	250	C	C	PASS

Criteria judgment of Test result:

- Meet criteria A: No abnormalities were observed during and directly after the test.
- Meet criteria B: Operate as intended after the test
- Meet criteria C: Loss/Error of function
- Additional Information
  - EUT stopped operation and could be reset by operator.
  - No false alarms or other malfunctions were observed during or after the test.

Attachment 1 : EUT Test Photographs

## Attachment 1 : EUT Test Photographs

Front View of Conducted Test (Mode 1)



Back View of Conducted Test (Mode 1)

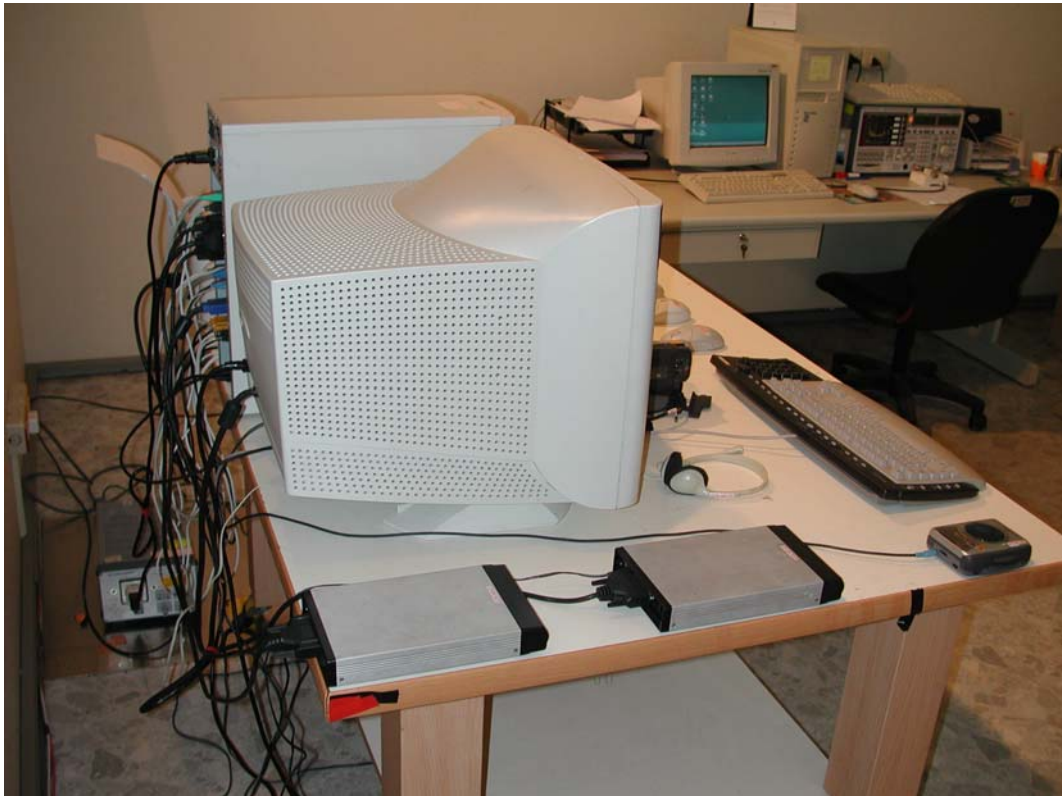

Front View of Conducted Test (Mode 2)



Back View of Conducted Test (Mode 2)





Front View of Radiated Test (Mode 1)



Back View of Radiated Test (Mode 1)



Front View of Radiated Test (Mode 2)



Back View of Radiated Test (Mode 2)



Harmonics Test Setup



ESD Test Setup





RS Test Setup



EFT/B Test Setup





Surge Test Setup



CS Test Setup



Power Frequency Magnetic Field Test Setup



Dips Test Setup



## Attachment 2 : EUT Detailed Photographs

## Attachment 2 : EUT Detailed Photographs

(1) EUT Photo



(2) EUT Photo





(3) EUT Photo



(4) EUT Photo



(5) EUT Photo



(6) EUT Photo





(7) EUT Photo



(8) EUT Photo



(9) EUT Photo



(10) EUT Photo

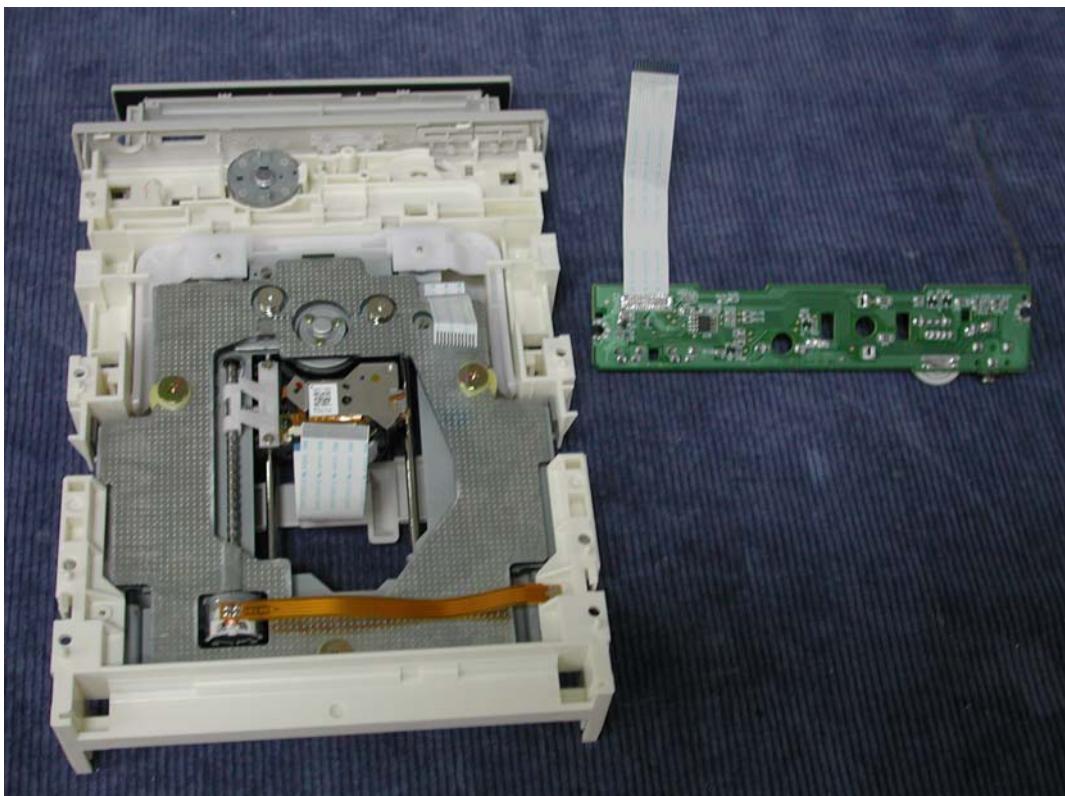



(11) EUT Photo

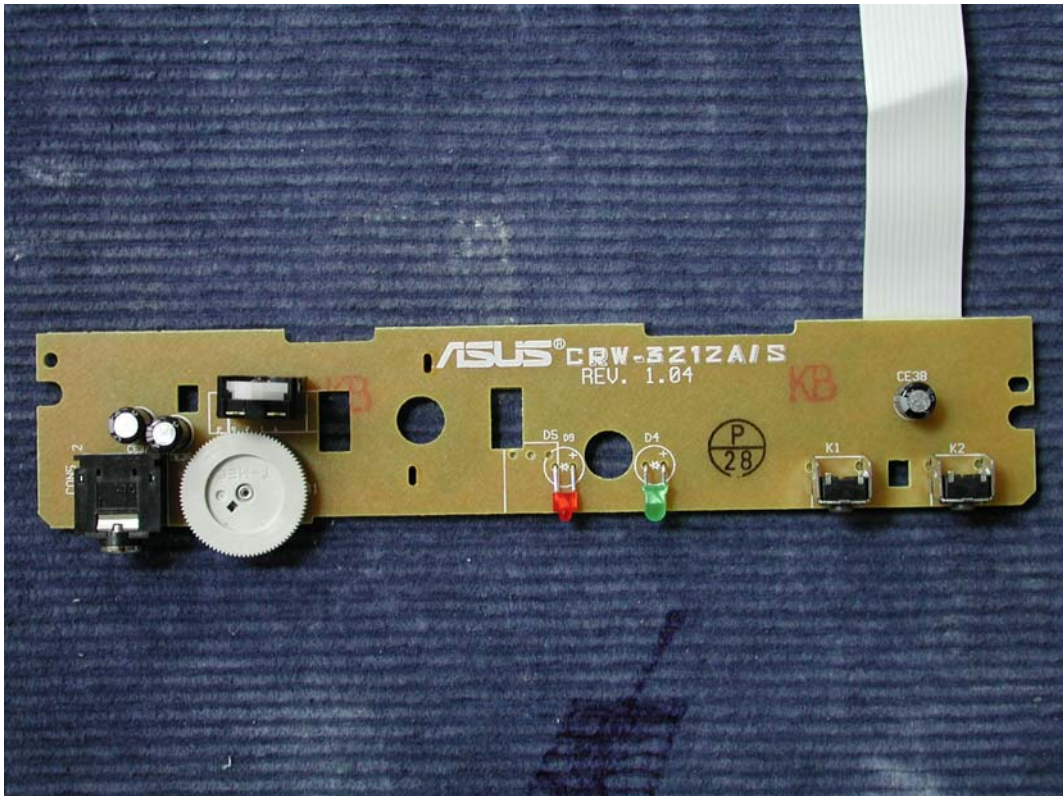

(12) EUT Photo

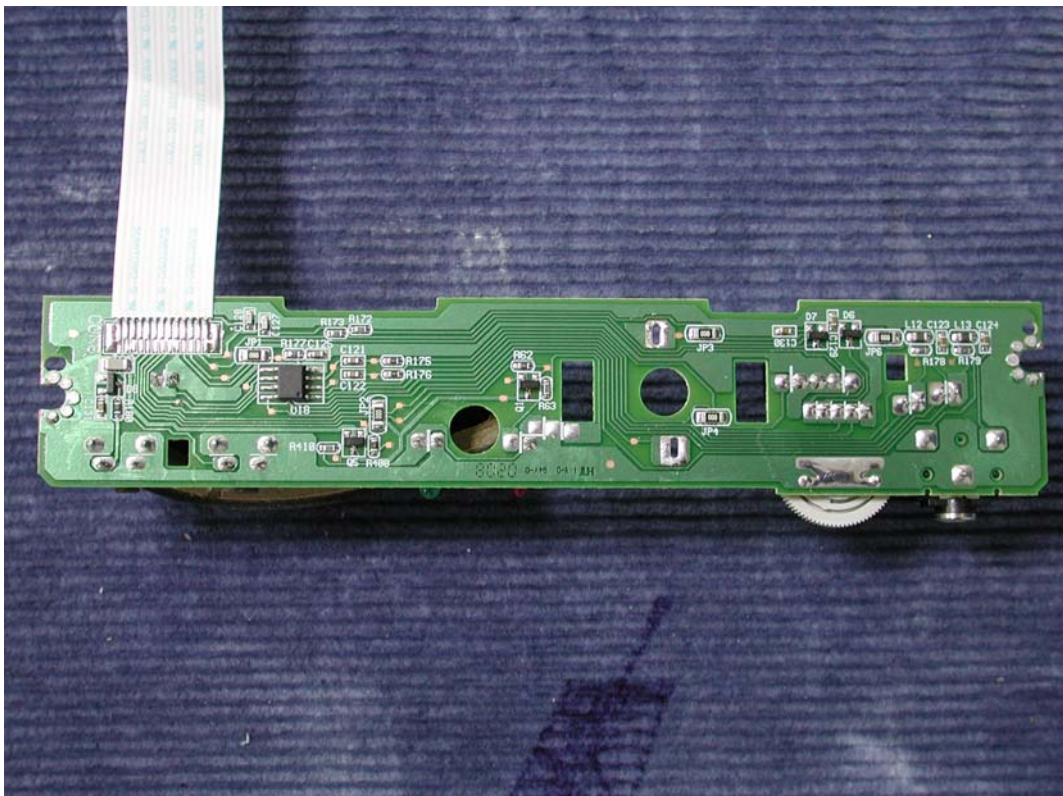



(13) EUT Photo

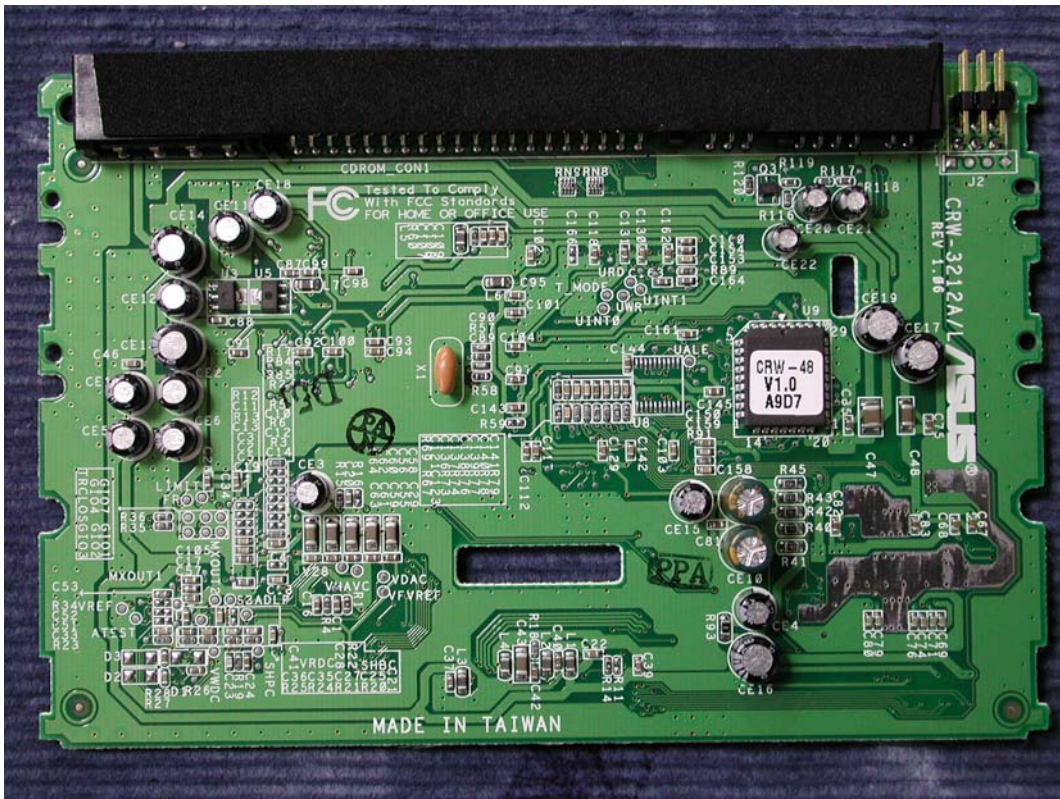

(14) EUT Photo

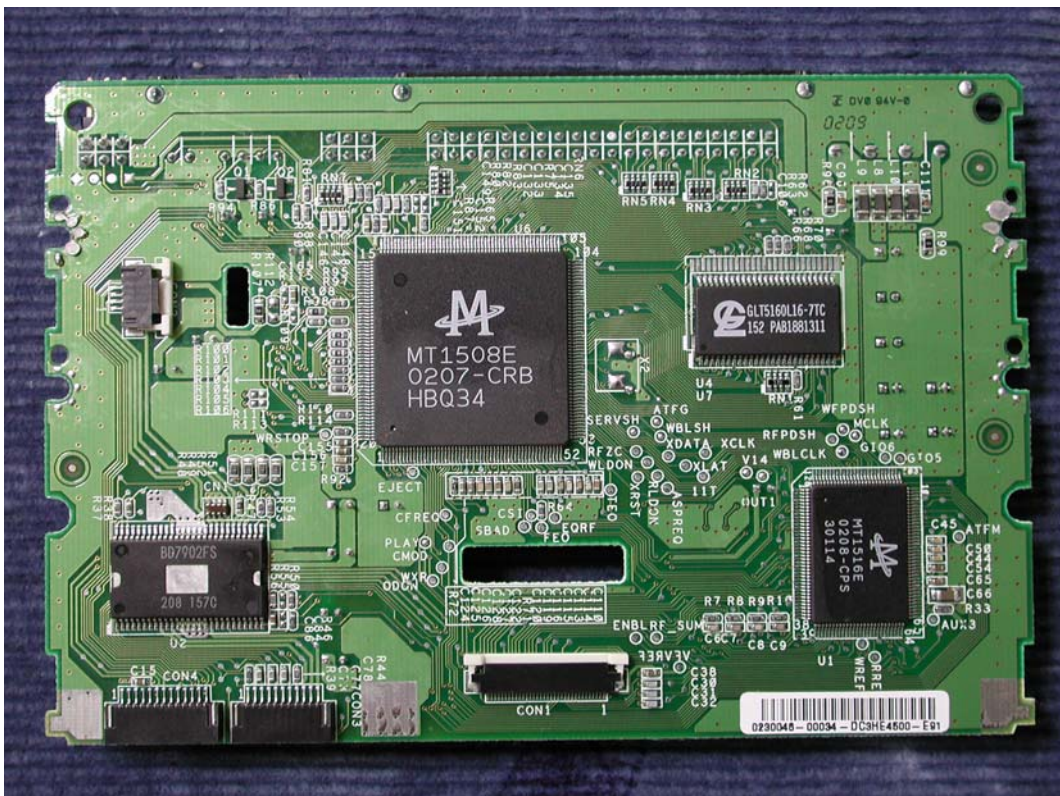



(15) EUT Photo

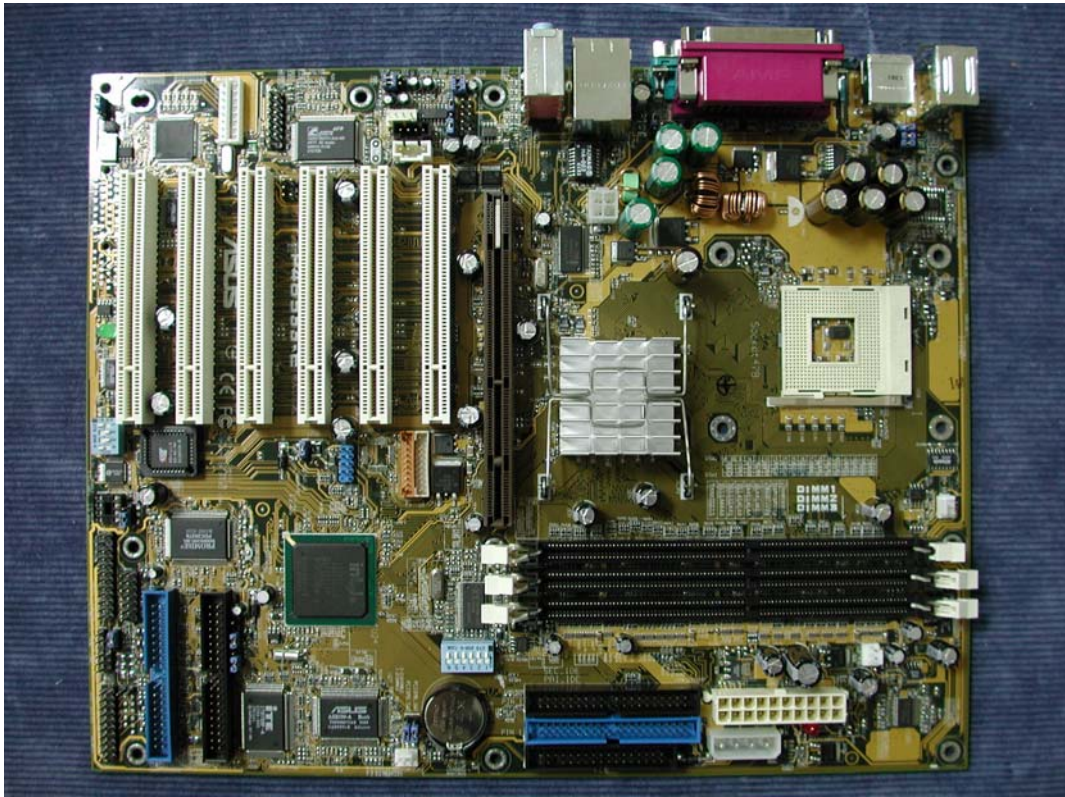

(16) EUT Photo

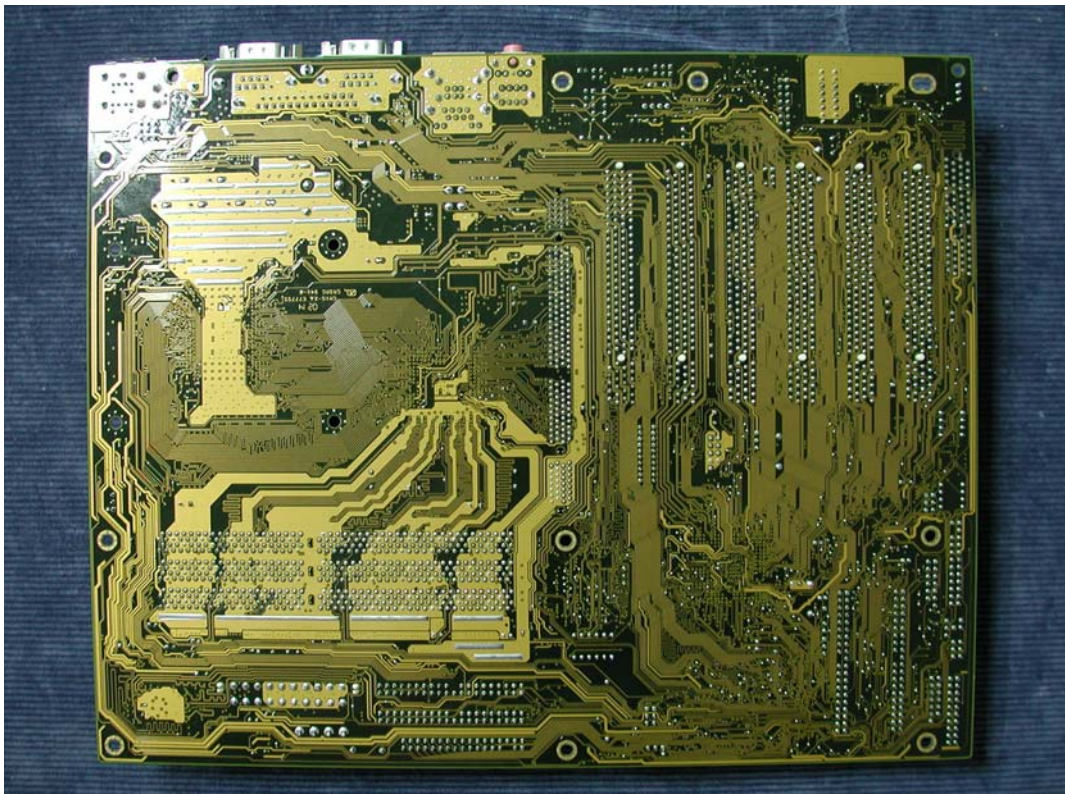

**Reference : Laboratory of License**



## Scope of Accreditation



### ELECTROMAGNETIC COMPATIBILITY AND TELECOMMUNICATIONS

NVLAP LAB CODE 200533-0

#### QUITEK CORPORATION

No. 5, Ruei-shu Valley, Ruei-ping, Tsuen  
Lin Kou Shiang, Taipei 244  
TAIWAN

Mr. Gene Chang

Phone: 886-2-8601-3788 Fax: 886-2-8601-3789

E-Mail: gene@quietek.com

#### *NVLAP Code Designation / Description*

#### **Emissions Test Methods:**

12/CIS22	IEC/CISPR 22 (1997) and EN 55022 (1998): Limits and methods of measurement of radio disturbance characteristics of information technology equipment
12/CIS22a	IEC/CISPR 22:1993: Limits and methods of measurement of radio disturbance characteristics of information technology equipment, Amendment 1:1995, and Amendment 2:1996.
12/CIS22b	CNS 13438:1997: Limits and Methods of Measurement of Radio Interference Characteristics of Information Technology Equipment
12/F01	FCC Method - 47 CFR Part 15 - Digital Devices
12/F01a	Conducted Emissions, Power Lines, 450 KHz to 30 MHz
12/F01b	Radiated Emissions

June 30, 2003

*Effective through*

*For the National Institute of Standards and Technology*

## Scope of Accreditation



### ELECTROMAGNETIC COMPATIBILITY AND TELECOMMUNICATIONS

NVLAP LAB CODE 200533-0

#### QUITEK CORPORATION

*NVLAP Code*    *Designation / Description*

12/T51            AS/NZS 3548: Electromagnetic Interference - Limits and Methods of Measurement  
of Information Technology Equipment

#### Immunity Test Methods:

- 12/I01            IEC 61000-4-2 (1995) and Amendment 1 (1998): Electrostatic Discharge Immunity  
Test
- 12/I02            IEC 61000-4-3 (1995) and Amendment 1 (1998): Radiated, Radio-Frequency  
Electromagnetic Field Immunity Test
- 12/I03            IEC 61000-4-4 (1995): Electrical Fast Transient/Burst Immunity Test
- 12/I04            IEC 61000-4-5 (1995): Surge Immunity Test
- 12/I05            IEC 61000-4-6 (1996): Immunity to Conducted Disturbances, Induced  
Radio-Frequency Fields
- 12/I06            IEC 61000-4-8 (1993): Power Frequency Magnetic Field Immunity Test
- 12/I07            IEC 61000-4-11 (1994): Voltage Dips, Short Interruptions and Voltage Variations  
Immunity Tests

June 30, 2003

*David F. Alderman*

*Effective through*

*For the National Institute of Standards and Technology*

United States Department of Commerce  
National Institute of Standards and Technology

**NVLAP**<sup>®</sup>

ISO/IEC GUIDE 25:1990  
ISO 9002:1987

**Certificate of Accreditation**



**QUITEK CORPORATION**

LIN KOU SHIANG, TAIPEI 244  
TAIWAN

*is recognized under the National Voluntary Laboratory Accreditation Program for satisfactory compliance with criteria established in Title 15, Part 285 Code of Federal Regulations. These criteria encompass the requirements of ISO/IEC Guide 25 and the relevant requirements of ISO 9002 (ANSI/ASQC Q92-1987) as suppliers of calibration or test results. Accreditation is awarded for specific services, listed on the Scope of Accreditation for:*

**ELECTROMAGNETIC COMPATIBILITY AND TELECOMMUNICATIONS**

June 30, 2003

*Effective through*

*David F. Alderman*

*For the National Institute of Standards and Technology*

NVLAP Lab Code: 200533-0



## **EMC Laboratory Authorisation**

**Aut. No. : ELA 165**

**EMC Laboratory:**

**QuieTek Corporation  
No. 75-2, Wang-Yeh Valley,  
Yung-Hsing, Chiung-Lin, Hsin-Chu,  
Hsin-Chu County, Taiwan R.O.C.**

**Scope of Authorization: All CENELEC standards [ENs] for EMC that are listed on the accompanying page, and, all of the corresponding CISPR, IEC, and ISO EMC standards that are listed on the accompanying page.**

This Authorisation Document confirms that the above mentioned EMC Laboratory has been validated against EN 45001 and found to be compliant. The laboratory also fulfils the conditions described in Nemko Document ELA 10. During Nemko's visit to the laboratory, an assessment was made of the relevant parts of your organisation - i.e. facilities, personnel qualifications, test equipment, and testing practices. It was found that the EMC Laboratory is capable of performing tests within the Scope of Authorisation given on the accompanying page. Accordingly, Nemko will accept your test reports as a basis for attesting conformity to these EMC Standards for the products in question under the European Union EMC Directive [89/336/EEC as amended by 92/31/EEC and 98/13/EC].

In case of applications for Product Certification(s) to be issued by Nemko, your EMC Laboratory's test report(s) will be accepted by Nemko if they are enclosed with the Application Form submitted by the manufacturer.

In order to maintain this Authorization, the information given in the enclosed ELA-INFOs (if any) must be carefully followed. Nemko is to be promptly notified about any changes in the situation at your EMC Laboratory which may affect the basis for this Authorization. The Authorization may at any time be withdrawn if the conditions are no longer considered to be fulfilled.

The Authorisation is valid through **31. December 2003**.

**Oslo, 18. April 2001**

For Nemko AS:

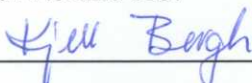

Kjell Bergh, Nemko Group EMC Co-ordinator



## **EMC Laboratory Authorisation**

**Aut. No. : ELA 162**

EMC Laboratory:

**QuieTek Corporation  
No. 75-2, Wang-Yeh Valley,  
Yung-Hsing, Chiung-Lin, Hsin-Chu,  
Hsin-Chu County, Taiwan R.O.C.**

Scope of Authorization:

**EN 60601-1-2 and IEC 60601-1-2, the Collateral Standards  
for electromedical products, with particular application to  
EMC requirements only.**

This Authorisation Document confirms that the above mentioned EMC Laboratory has been validated against EN 45001 and found to be compliant. The laboratory also fulfils the conditions described in Nemko Document ELA 10. During Nemko's visit to the laboratory, an assessment was made of the relevant parts of your organisation - i.e. facilities, personnel qualifications, test equipment, and testing practices. It was found that the EMC Laboratory is capable of performing tests within the Scope of Authorisation listed above. Accordingly, Nemko will accept your test reports as a basis for attesting conformity to these EMC Standards for the products in question under either the European Union Medical Device Directive [MDD], 93/42/EEC, or the European Union Active Implantable Medical Device Directive [AIMD], 90/385/EEC, (as applicable).

In case of applications for Product Certification(s) to be issued by Nemko, your EMC Laboratory's test report(s) will be accepted by Nemko if they are enclosed with the Application Form submitted by the manufacturer.

In order to maintain the Authorisation, the information given in the enclosed ELA-INFOs (if any) must be carefully followed. Nemko is to be promptly notified about any changes in the situation at your EMC Laboratory which may affect the basis for this Authorisation. The Authorisation may at any time be withdrawn if the conditions are no longer considered to be fulfilled.

The Authorisation is valid through **31. December 2001**.

**Oslo, 18. April 2001**

For Nemko AS:

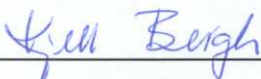

Kjell Bergh, Nemko Group EMC Co-ordinator

## EMC Laboratory Authorisation

Aut. No. : ELA 191

(Page 2 of 2)

### SCOPE OF AUTHORISATION

#### Generic and product-family standards – R&TTE Directive

EN 300 220-3 :2000	ETS 300 328:1996 + A1:97 EN 300 328-2:2000	I-ETS 300 330:1994 + A1:97 (Not harmonised for R&TTE-D)
EN 300 422-2 :2000	I-ETS 300 440:1995 (Not harmonised for R&TTE-D)	ETS 300 445 :1996 + A1 :97 EN 301 489-09 :2000
ETS 300 683 :1997 EN 301 489-03 :2000	ETS 300 826 :1997 EN 301 489-17 :2000	EN 301 489-01:2000

#### Basic standards

EN 61000-4-2:1995 + A1:98 IEC 61000-4-2:1995 + A1:98  (EN 60801-1:1993 IEC 801.2:1991 IEC 801.2:1984)	EN 61000-4-3:1996 + A1:98 IEC 61000-4-3:1995 + A1:98  (IEC 801.3:1984 ENV 50140:1993 + ENV 50204:1995)	EN 61000-4-4:1995 IEC 61000-4-4:1995  (IEC 801.4:1990)
EN 61000-4-5:1995 IEC 61000-4-5:1995  (ENV 50142:1994)	EN 61000-4-6:1996 IEC 61000-4-6:1996  (ENV 50141:1993)	EN 61000-4-8:1993 IEC 61000-4-8:1993
EN 61000-4-11:1994 IEC 61000-4-11:1994		

Oslo, 24 April 2001

Kjell Bergh, Nemko Group EMC Co-ordinator



**EMC Laboratory  
Authorisation****Aut. No. : ELA 162**

EMC Laboratory: **QuieTek Corporation  
No. 75-2, Wang-Yeh Valley,  
Yung-Hsing, Chiung-Lin, Hsin-Chu,  
Hsin-Chu County, Taiwan R.O.C.**

Scope of Authorization: **EN 60601-1-2 and IEC 60601-1-2, the Collateral Standards  
for electromedical products, with particular application to  
EMC requirements only.**

This Authorisation Document confirms that the above mentioned EMC Laboratory has been validated against EN 45001 and found to be compliant. The laboratory also fulfils the conditions described in Nemko Document ELA 10. During Nemko's visit to the laboratory, an assessment was made of the relevant parts of your organisation - i.e. facilities, personnel qualifications, test equipment, and testing practices. It was found that the EMC Laboratory is capable of performing tests within the Scope of Authorisation listed above. Accordingly, Nemko will accept your test reports as a basis for attesting conformity to these EMC Standards for the products in question under either the European Union Medical Device Directive [MDD], 93/42/EEC, or the European Union Active Implantable Medical Device Directive [AIMD], 90/385/EEC, (as applicable).

In case of applications for Product Certification(s) to be issued by Nemko, your EMC Laboratory's test report(s) will be accepted by Nemko if they are enclosed with the Application Form submitted by the manufacturer.

In order to maintain the Authorisation, the information given in the enclosed ELA-INFOs (if any) must be carefully followed. Nemko is to be promptly notified about any changes in the situation at your EMC Laboratory which may affect the basis for this Authorisation. The Authorisation may at any time be withdrawn if the conditions are no longer considered to be fulfilled.

The Authorisation is valid through **31. December 2003.**

**Oslo, 24. April 2001**

For Nemko AS:

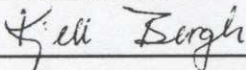
**Kjell Bergh, Nemko Group EMC Co-ordinator**



**EMC Laboratory Authorisation**
**Aut. No. : ELA 165**
**(Page 2 of 2)**
**SCOPE OF AUTHORIZATION**
**GENERIC & PRODUCT-FAMILY STANDARDS**

EN 50081-1:1992 IEC 61000-6-3  EN 50081-2:1993 IEC 61000-6-4:1997	EN 50082-1:1992 EN 50082-1 :1997 IEC 61000-6-1:1997  EN 50082-2:1995 EN 61000-6-2:1999 IEC 61000-6-2:1999	EN 50091-2:1995
EN 50130-4:1995 + A1:98	EN 55011:1991 + A1:97 + A2:96 CISPR 11:1990 + A1:96 + A2:96 EN 55011:1998 + CISPR 11:97	EN 55013:90 + A12:94 + A13:96 + A14 :99 CISPR 13:75 + A1:83
EN 55014-1:1993 + A1:97 + A2 :99 CISPR 14:1993 + A1:96 + A2 :	EN 55014-2:1997 CISPR 14-2:1997 EN 55104:1995	EN 55015:1993, CISPR 15:1992 EN 55015:1996 + A1:97 CISPR 15:96 + A1:97
EN 55022:1994 + A1:95 + A2:97 CISPR 22:1993 + A1:95 + A2:96 EN 55022:1998, CISPR 22:1997	EN 55024:1998 CISPR 24:1997	EN 55103-1:1996
EN 55103-2:1996		
EN 61000-3-2:1995 + A1:98 + A2:98 + A14 :00 IEC 61000-3-2:1995 + A1:97 + A2:98 IEC 61000-3-2 :2000	EN 61000-3-3:1995, IEC 61000-3-3:1994 EN 61000-3-11 :2000 IEC 61000-3-11 :2000	EN 61326-1:1997 + A1:98 IEC 61326:1997 + A1:98

**BASIC STANDARDS**

EN 61000-4-2:1995 + A1:98 IEC 61000-4-2:1995 + A1:98  (EN 60801-1:1993 IEC 801.2:1991 IEC 801.2:1984)	EN 61000-4-3:1996 + A1:98 IEC 61000-4-3:1995 + A1:98  (IEC 801.3:1984 ENV 50140:1993 + ENV 50204:1995)	EN 61000-4-4:1995 IEC 61000-4-4:1995  (IEC 801.4:1990)
EN 61000-4-5:1995 IEC 61000-4-5:1995  (ENV 50142:1994)	EN 61000-4-6:1996 IEC 61000-4-6:1996  (ENV 50141:1993)	EN 61000-4-8:1993 IEC 61000-4-8:1993
EN 61000-4-11:1994 IEC 61000-4-11:1994		

**Oslo, 24 April 2001**
**Kjell Bergh, Nemko Group EMC Co-ordinator**
*Postal address:*
*Telephone:* +47 22 96 03 30

P.O.Box 73 Blindern

*Fax:* +47 22 96 05 50

N-0314 OSLO, NORWAY



**EMC Laboratory Authorisation****Aut. No. : ELA 191****Testing of  
Radio & Telecommunications Terminal Equipment**

**EMC  
Laboratory:** **QuieTek Corporation**  
**No. 75-2, Wang-Yeh Valley,**  
**Yung-Hsing, Chiung-Lin, Hsin-Chu,**  
**Hsin-Chu County, Taiwan R.O.C.**

**Scope of  
Authorisation:** **All CENELEC and ETSI standards [ENs and ETSs that are listed on the  
accompanying page, and, all of the corresponding CISPR, IEC, and ISO EMC  
standards]. This authorisation covers all of the EMC-related testing and  
documentation within the scope of the *Radio and Telecommunications Terminal  
Equipment [R&TTE] Directive [i.e. 1999/5/EC].***

**NOTE: This authorisation also covers EMC-related testing and documentation  
that is within the scope of Article 10.5 of the *EMC Directive [i.e. 89/336/EEC as  
amended by 92/31/EEC]***

This Authorisation Document confirms that the above mentioned EMC Laboratory has been validated against EN 45001 and found to be compliant. The laboratory also fulfils the conditions described in Nemko Document ELA 10. During Nemko's visit to the laboratory, an assessment was made of the relevant parts of your organisation - i.e. facilities, personnel qualifications, test equipment, and testing practices. It was found that the EMC Laboratory is capable of performing tests within the Scope of Authorisation given on the accompanying page. Accordingly, Nemko will accept your test reports as a basis for attesting conformity to these EMC Standards for the products in question under the European Union's Directives specified above

For Type Examination Certification(s) to be issued by Nemko, your EMC Laboratory's test report(s) will be accepted by Nemko if they are enclosed with the Application Form submitted by the manufacturer.

In order to maintain the Authorisation, the information given in the enclosed ELA-INFOs (if any) must be carefully followed. Nemko is to be promptly notified about any changes in the situation at your EMC Laboratory which may affect the basis for this Authorisation. The Authorisation may at any time be withdrawn if the conditions are no longer considered to be fulfilled.

The Authorisation is valid through **31. December 2003.**

**Oslo, 24. April 2001**

For Nemko AS:

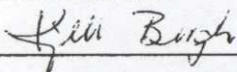
  
\_\_\_\_\_

Kjell Bergh, Nemko Group EMC Co-ordinator