

CE

Test Report

Product Name	:	VGA Card
Model No.	:	V8420/TD/128M, V8420/DVI/128M, V8420/TD/64M, V8420/DVI/64M

Applicant	:	ASUSTeK COMPUTER INC.
Address	:	4Fl., No. 150, Li-Te Rd., Peitou, Taipei, Taiwan, R.O.C.

Date of Receipt	:	Jul. 10, 2002
Date of Test	:	Jul. 16, 2002
Report No.	:	027L030E

The test results relate only to the samples tested.

The test report shall not be reproduced except in full without the written approval of Quietek Corporation.



Declaration of Conformity

The following products is herewith confirmed to comply with the requirements set out in the Council Directive on the Approximation of the laws of the Member States relating to Electromagnetic Compatibility Directive (89/336/EEC). The listed standard as below were applied:

The following Equipment:

Product : VGA Card
Trade Name : ASUS
Model Number : V8420/TD/128M, V8420/DVI/128M,
V8420/TD/64M, V8420/DVI/64M

This product is herewith confirmed to comply with the requirements set out in the Council Directive on the Approximation of the laws of the Member States relating to Electromagnetic Compatibility Directive (89/336/EEC). For the evaluation regarding EMC, the following standards were applied:

RFI Emission:

EN 55022:1998 Class B : Product family standard
EN 61000-3-2:1995 Class D : Limits for harmonic current emission
Amendment 1:1998
Amendment 2:1998
EN 61000-3-3:1995 : Limitation of voltage fluctuation and flicker in low-voltage supply system

Immunity :

EN 55024:1998 : Product family standard

The following importer/manufacturer is responsible for this declaration:

Company Name : _____
Company Address : _____
Telephone : _____ Facsimile : _____

Person is responsible for marking this declaration:

Name (Full Name)

Position/ Title

Date

Legal Signature



Quietek Corporation

EMC/Safety Test Laboratory
Accredited by DNV, TUV, Nemko and NVLAP

Date: Jul. 16, 2002
QTK No.: 027L030E



Statement of Conformity

The certifies that the following designated product

Product : VGA Card
 Trade Name : ASUS
 Model Number : V8420/TD/128M, V8420/DVI/128M,
 V8420/TD/64M, V8420/DVI/64M
 Company Name : ASUSTeK COMPUTER INC.

This product is herewith confirmed to comply with the requirements set out in the Council Directive on the Approximation of the laws of the Member States relating to Electromagnetic Compatibility Directive (89/336/EEC). For the evaluation regarding EMC, the following standards were applied:

RFI Emission:

EN 55022:1998 Class B : Product family standard
 EN 61000-3-2:1995 Class D : Limits for harmonic current emission
 Amendment 1:1998
 Amendment 2:1998
 Amendment 14:2000 : Limitation of voltage fluctuation and flicker in low-voltage supply system
 EN 61000-3-3:1995

Immunity :

EN 55024:1998 : Product family standard



TEST LABORATORY

Gene Chang
Gene Chang/ Manager

The verification is based on a single evaluation of one sample of above-mentioned products. It does not imply an assessment of the whole production and does not permit the use of the test lab. Logo.

Test Report Certification

Test Date: Jul. 16, 2002

Report No. : 027L030E



Accredited by TUV, DNV, Nemko and NIST (NVLAP)

Product Name : VGA Card

Applicant : ASUSTeK COMPUTER INC.

Address : 4Fl., No. 150, Li-Te Rd., Peitou, Taipei, Taiwan, R.O.C.

Manufacturer : ASUSTeK COMPUTER INC.

Model No. : V8420/TD/128M, V8420/DVI/128M, V8420/TD/64M,
V8420/DVI/64M

Rated Voltage : Power by PC

Trade Name : ASUS

Measurement Standard : EN 55022:1998 Class B
EN 61000-3-2:1995, Amendment 1:1998, Amendment 2:1998,
Amendment 14:2000, EN 61000-3-3:1995
EN 55024:1998

Measurement Procedure : EN 55022:1998, EN 61000-3-2:1995, EN 61000-3-3:1995,
IEC 61000-4-2:1995, IEC 61000-4-3:1995, IEC 61000-4-4:1995,
IEC 61000-4-5:1995, IEC 61000-4-6:1996, IEC 61000-4-8:1993,
IEC 61000-4-11:1994

Test Result : Complied

The test results relate only to the samples tested.

The test report shall not be reproduced except in full without the written approval of Quietek Corporation.

Documented By : Cherry Yu
(Cherry Yu)



Tested By : Eddie Lin
(Eddie Lin)

Reviewed By : Murphy Wang
(Murphy Wang)



Approved By : Gene Chang
(Gene Chang)



Test Report Certification

Test Date: Jul. 16, 2002

Report No. : 027L030E



Accredited by NIST (NVLAP)
NVLAP Lab Code: 200533-0

Product Name : VGA Card

Applicant : ASUSTeK COMPUTER INC.

Address : 4Fl., No. 150, Li-Te Rd., Peitou, Taipei, Taiwan, R.O.C.

Manufacturer : ASUSTeK COMPUTER INC.

Model No. : V8420/TD/128M, V8420/DVI/128M, V8420/TD/64M,
V8420/DVI/64M

Rated Voltage : Power by PC

Trade Name : ASUS

Measurement Standard : AS/NZS 3548: 1995

Measurement Procedure : AS/NZS 3548: 1995

Classification : Class B

Test Result : Complied



The Test Results relate only to the samples tested.
 The test report shall not be reproduced except in full without the written approval of Quietek Corporation.
 This report must not be used to claim product endorsement by NVLAP any agency of the U.S. Government

Documented By : Cherry Yu
(Cherry Yu)

Tested By : Eddie Lin
(Eddie Lin)

Reviewed By : Murphy Wang
(Murphy Wang)

Approved By : Gene Chang
(Gene Chang)

TABLE OF CONTENTS

Description	Page
1. General Information	6
1.1. EUT Description.....	6
1.2. Tested System Details.....	7
1.3. Configuration of Tested System	8
1.4. EUT Exercise Software	9
1.5. Test Facility	10
2. Conducted Emission.....	11
2.1. Test Equipment List.....	11
2.2. Test Setup	11
2.3. Limits	12
2.4. Test Procedure	12
2.5. Test Specification	12
2.6. Test Result	12
3. Radiated Emission.....	13
3.1. Test Equipment.....	13
3.2. Test Setup	13
3.3. Limits	14
3.4. Test Procedure	14
3.5. Test Specification	14
3.6. Test Result	14
4. Power Harmonics and Voltage Fluctuation	15
4.1. Power Harmonics and Voltage Fluctuation Test Equipment List.....	15
4.2. Test Setup	15
4.3. Limits	15
4.4. Test Procedure	16
4.5. Test Specification	16
4.6. Test Result	16
5. Electrostatic Discharge (ESD).....	17
5.1. Test Equipment.....	17
5.2. Test Setup	17
5.3. Test Level	17
5.4. Test Procedure	18
5.5. Test Specification	18
5.6. Test Result	18
6. Radiated Susceptibility (RS).....	19
6.1. Test Equipment.....	19
6.2. Test Setup	19
6.3. Test Level	19
6.4. Test Procedure	20
6.5. Test Specification	20
6.6. Test Result	20
7. Electrical Fast Transient/Burst (EFT/B)	21
7.1. Test Equipment.....	21
7.2. Test Setup	21
7.3. Test Level	21
7.4. Test Procedure	22
7.5. Test Specification	22
7.6. Test Result	22
8. Surge.....	23

8.1.	Test Equipment.....	23
8.2.	Test Setup	23
8.3.	Test Level	23
8.4.	Test Procedure	24
8.5.	Test Specification	24
8.6.	Test Result	24
9.	Conducted Susceptibility (CS).....	25
9.1.	Test Equipment.....	25
9.2.	Test Setup	25
9.3.	Test Level	26
9.4.	Test Procedure	26
9.5.	Test Specification	26
9.6.	Test Result	26
10.	Power Frequency Magnetic Field	27
10.1.	Test Equipment.....	27
10.2.	Test Setup	27
10.3.	Test Level	27
10.4.	Test Procedure	28
10.5.	Test Specification	28
10.6.	Test Result	28
11.	Voltage Dips and Interruption Measurement	29
11.1.	Test Equipment.....	29
11.2.	Test Setup	29
11.3.	Test Level	29
11.4.	Test Procedure	30
11.5.	Test Specification	30
11.6.	Test Result	30
12.	EMC Reduction Method During Compliance Testing	31
13.	Test Result	32
13.1.	Test Data of Conducted Emission	33
13.2.	Test Data of Radiated Emission	36
13.3.	Test Data of Power Harmonics.....	42
13.4.	Test Data of Electrostatic Discharge	51
13.5.	Test Data of Radiated Susceptibility	52
13.6.	Test Data of Electrical Fast Transient.....	53
13.7.	Test Data of Surge	54
13.8.	Test Data of Conducted Susceptibility	55
13.9.	Test Data of Power Frequency Magnetic Field	56
13.10.	Test Data of Voltage Dips and Interruption	57

ATTACHMENT 1: EUT TEST PHOTOGRAPHS

ATTACHMENT 2: EUT DETAILED PHOTOGRAPHS

REFERENCE : LABORATORY OF LICENSE

1. General Information

1.1. EUT Description

Product Name	:	VGA Card
Trade Name	:	ASUS
Model No.	:	V8420/TD/128M, V8420/DVI/128M, V8420/TD/64M, V8420/DVI/64M

Note:

1. The EUT is a VGA Card that maximum resolution 1920*1440/75Hz.
2. It has one D-SUB port, one DVI port, and one S-Video port.
3. The different between model numbers was for different functions shown as list:

Model numbers	Function
V8420/TD /128M	CRT+TV+DVI
V8420/DVI/128M	CRT+DVI
V8420/TD/64M	CRT+TV+DVI
V8420/DVI/64M	CRT+DVI

4. QuieTek has verified the construction and function in typical operation. All the test modes were carried out with the EUT in normal operation, which was shown in this test report and defined as:

EMI Test	:	Mode 1: 1920*1440/75Hz (D-SUB+DVI) Mode 2: 1600*1200/85Hz (D-SUB+S-Video) Mode 3: 1024*768/60Hz (DVI+AV)
EMS Test	:	Mode 1: 1920*1440/75Hz (D-SUB+DVI)

1.2. Tested System Details

The types for all equipment, plus descriptions of all cables used in the tested system (including inserted cards) are:

	Product	Manufacturer	Model No.	Serial No.	FCC ID	Power Cord
(1)	PC	ASUS	AB-C2101	S/N	FCC DoC	Non-shielded, 1.8m
(2)	D-SUB Monitor	SONY	CPD-G500	2738406	FCC DOC	Non-shielded, 1.8m
(3)	Modem	ACEEX	DM-1414	0102027542	IFAXDM1414	Non-shielded, 1.8m
(4)	Printer	EPSON	Color 680	023913	FCC DoC	Non-shielded, 1.9m
(5)	Keyboard	HP	SK-2506	C00083358	FCC DOC	N/A
(6)	Mouse	IBM	M-SAU-IBM6	23-022623	FCC DOC	N/A
(7)	USB Mouse	Logitech	M-BE58	LZE11405266	FCC DOC	N/A
(8)	USB Mouse	Logitech	M-BE58	LZE11405306	FCC DOC	N/A
(9)	Walkman	AIWA	HS-TA164	N/A	FCC DOC	N/A
(10)	Microphone & Earphone	TOKTO	SX-MI	N/A	FCC DOC	N/A
(11)	Joystick	GENIUS	MAXFIRE FORCE G-09D	CJ0100200573	FCC ID:FSUGG09	N/A
(12)	Monitor	SONY	PVM-14M2U	2105742	FCC DOC	Non-shielded, 1.8m
(13)	DVI Monitor	TATUNG	L5-PVT	N/A	N/A	Non-shielded, 1.8m

	Signal Cable Type	Signal cable Description
A.	RS232 Cable	Shielded, 1.5m
B.	AUDIO Cable	Non-Shielded, 1.5m
C.	VGA Cable	Shielded, 1.8m, two ferrite cores bonded
D.	Earphone Cable	Non-Shielded, 1.8m
E.	Keyboard Cable	Shielded, 1.8m
F.	DVI Cable	Shielded, 1.8m, two ferrite cores bonded
G.	PS/2 Mouse Cable	Shielded, 1.8m
H.	USB Mouse Cable	Shielded, 1.8m
I.	USB Mouse Cable	Shielded, 1.8m
J.	Joystick Cable	Shielded, 1.8m
K.	S-Video Cable	Shielded 1.5m
L.	Printer Cable	Shielded, 1.5m
M.	LAN Cable	Non-shielded 3.0m
N.	RCA Cable	Non-shielded 1.5m

1.3. Configuration of Tested System

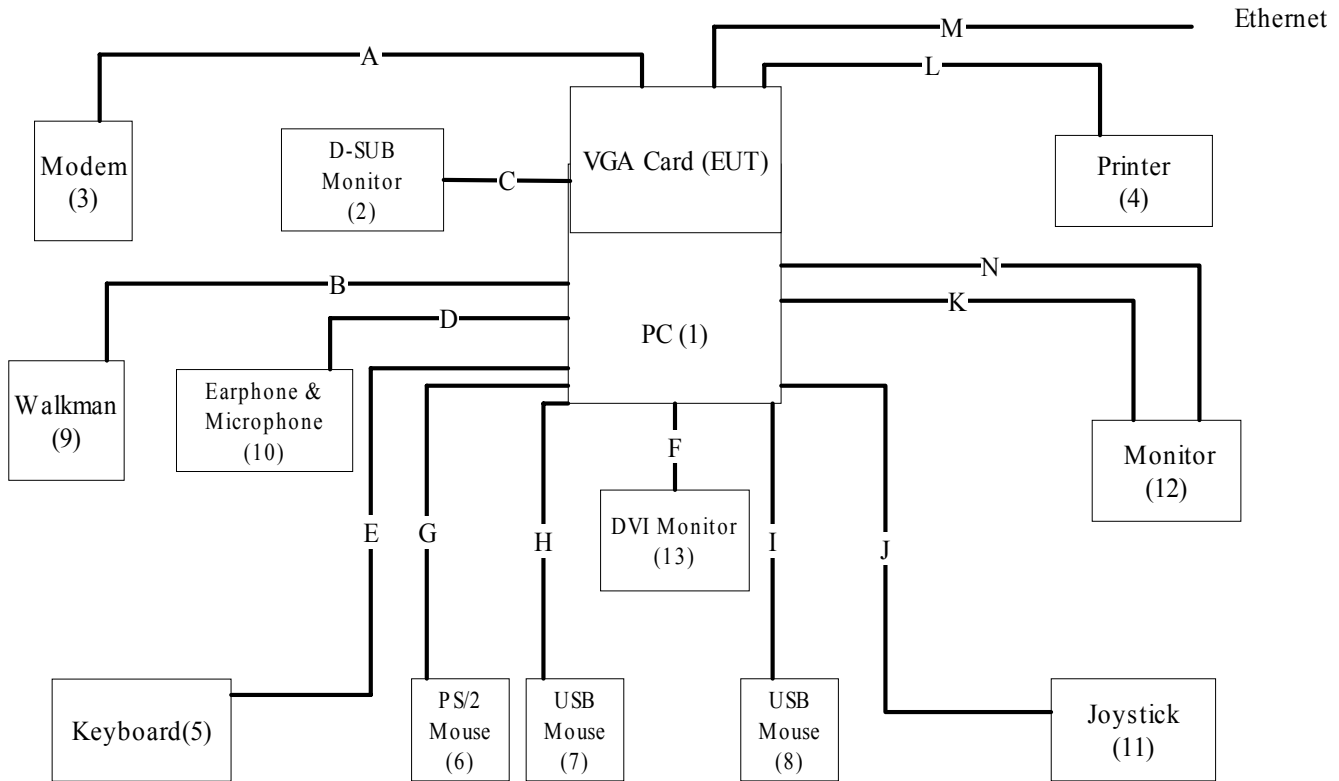

1.4. EUT Exercise Software

- (1) Setup the EUT and simulators as shown on 1.3.
- (2) Turn on the power of all equipment.
- (3) Personal Computer (EUT) reads data from disk.
- (4) EUT will sends "H" pattern to monitor, the monitor will show "H" pattern on the screen.
- (5) EUT sends "H" pattern to printer, the printer will print "H" pattern on paper.
- (6) EUT reads and writes data into and from modem.
- (7) EUT will read data from floppy disk and then writes the data into floppy disk, same operation for hard disk.
- (8) EUT Connect another simulation PC through LAN port and carry out Read/Write work each other.
- (9) Repeat the above procedure (3) to (7).
- (10) The CD ROM of EUT plays the audio signal and video picture during the test.

1.5. Test Facility

Ambient conditions in the laboratory:

Items	Test Item	Required (IEC 68-1)	Actual
Temperature (°C)	IEC 61000-4-2	15-35	20-35
Humidity (%RH)		30-60	50-60
Barometric pressure (mbar)		860-1060	950-1060
Temperature (°C)	IEC 61000-4-5	15-35	20-35
Humidity (%RH)		10-75	50-75
Barometric pressure (mbar)		860-1060	950-1060
Temperature (°C)	IEC 61000-4-4	15-35	20-35
Humidity (%RH)	IEC 61000-4-8	25-75	50-75
Barometric pressure (mbar)	IEC 61000-4-11	860-1060	950-1060

Site Description:

July 03, 2002 Accreditation on NVLAP
 NVLAP Lab Code: 200533-0



June 11, 2001 Accreditation on DNV
 Statement No. : 413-99-LAB11



May 03, 2001 Accreditation on TUV Rheinland
 Certificate No.: I9865712-9901



April 18, 2001 Accreditation on Nemko
 Certificate No.: ELA 165
 Certificate No.: ELA 162



Site Name: Quietek Corporation

Site Address: No. 5, Ruei-Shu Valley, Ruei-Ping Tsuen,
 Lin-Kou Shiang, Taipei,
 Taiwan, R.O.C.
 TEL : 886-2-8601-3788 / FAX : 886-2-8601-3789
 E-Mail : service@quietek.com

2. Conducted Emission

2.1. Test Equipment List

The following test equipment are used during the conducted emission test:

Item	Instrument	Manufacturer	Type No./Serial No	Last Cal.	Remark
1	Test Receiver	R & S	ESCS 30/838251/0001	May, 2002	
2	L.I.S.N.	R & S	ESH3-Z5/836679/0023	May, 2002	EUT
3	L.I.S.N.	R & S	ENV 4200/833209/0023	May, 2002	Peripherals
4	Pulse Limiter	R & S	ESH3-Z2	May, 2002	
5	N0.4 Shielded Room			N/A	

Note: All equipment upon which need to calibrated are with calibration period of 1 year.

2.2. Test Setup

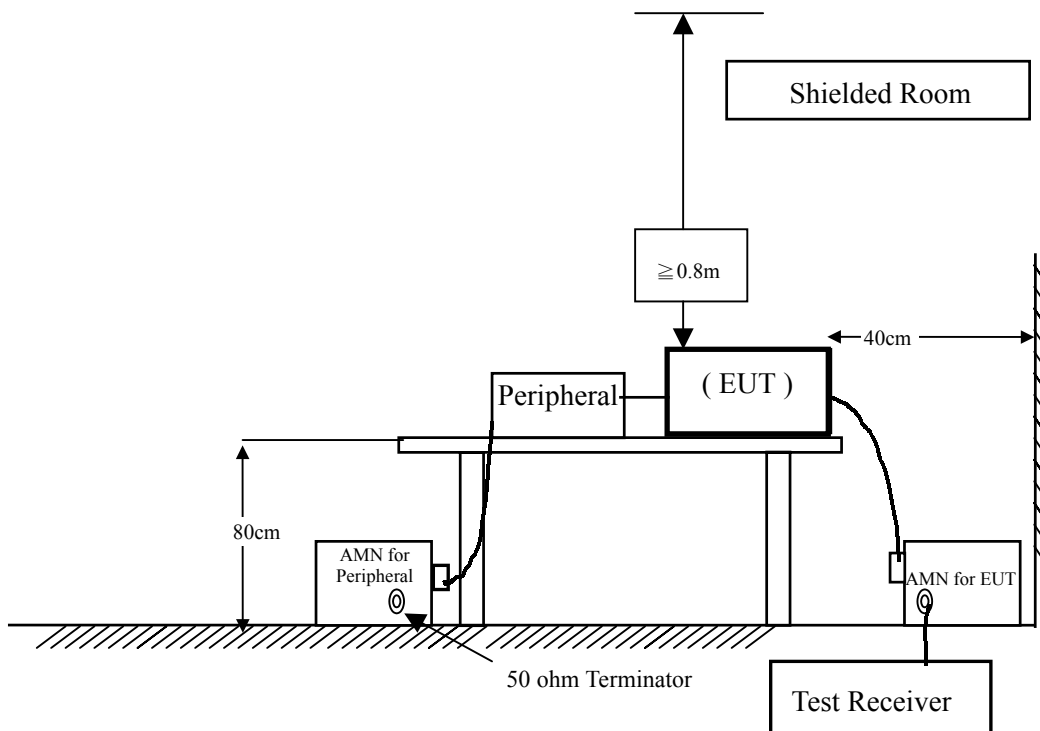

2.3. Limits

EN 55022 Limits (dBuV)				
Frequency MHz	Class A		Class B	
	QP	AV	QP	AV
0.15 - 0.50	79	66	66-56	56-46
0.50-5.0	73	60	56	46
5.0 - 30	73	60	60	50

Remarks : In the above table, the tighter limit applies at the band edges.

2.4. Test Procedure

The EUT and simulators are connected to the main power through a line impedance stabilization network (L.I.S.N.). This provides a 50 ohm /50uH coupling impedance for the measuring equipment. The peripheral devices are also connected to the main power through a LISN that provides a 50ohm /50uH coupling impedance with 50ohm termination. (Please refers to the block diagram of the test setup and photographs.)

Both sides of A.C. line are checked for maximum conducted interference. In order to find the maximum emission, the relative positions of equipment and all of the interface cables must be changed according to EN 55022:1998 on conducted measurement.

Conducted emissions were invested over the frequency range from 0.15MHz to 30MHz using a receiver bandwidth of 9kHz.

2.5. Test Specification

According to EN 55022:1998

2.6. Test Result

The emission from the EUT was below the specified limits. The worst-case emissions are shown in section 13. The acceptance criterion was met and the EUT passed the test.

3. Radiated Emission

3.1. Test Equipment

The following test equipment are used during the radiated emission test:

Test Site	Equipment	Manufacturer	Model No./Serial No.	Last Cal.
<input type="checkbox"/> Site # 1	Test Receiver	R & S	ESVS 10 / 834468/003	July, 2002
	Spectrum Analyzer	Advantest	R3162/ 00803480	May, 2002
	Pre-Amplifier	Advantest	BB525C/ 3307A01812	May, 2002
	Bilog Antenna	SCHAFFNER	CBL6112B / 2697	Nov., 2001
<input type="checkbox"/> Site # 2	Test Receiver	R & S	ESCS 30 / 836858 / 022	Nov., 2001
	Spectrum Analyzer	Advantest	3162 / 100803466	May, 2002
	Pre-Amplifier	Advantest	BB525C/3307A01814	May, 2002
	Bilog Antenna	SCHAFFNER	CBL6112B / 2705	Oct., 2001
<input checked="" type="checkbox"/> Site # 3	Test Receiver	R & S	ESI 26 / 838786 / 004	May, 2002
	Spectrum Analyzer	Advantest	3162 / 100803480	May, 2002
	Pre-Amplifier	QTK	QTK-AMP-03 / 0003	May, 2002
	Bilog Antenna	SCHAFFNER	CBL6112B / 2697	May, 2002
	Horn Antenna	ETS	3115 / 0005-6160	July, 2002
	Pre-Amplifier	QTK	QTK-AMP-01 / 0001	July, 2002

3.2. Test Setup

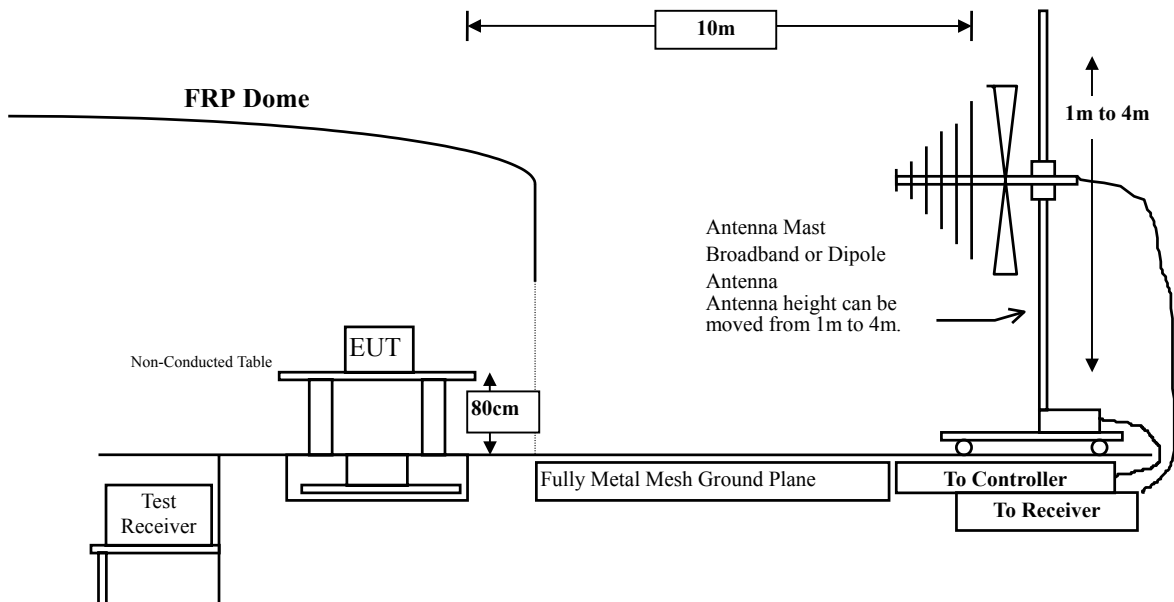

3.3. Limits

EN 55022 Limits (dBuV)				
Frequency MHz	Class A		Class B	
	Distance (m)	dBuV/m	Distance (m)	dBuV/m
30 – 230	10	40	10	30
230 – 1000	10	47	10	37

3.4. Test Procedure

The EUT and its simulators are placed on a turn table which is 0.8 meter above ground. The turn table can rotate 360 degrees to determine the position of the maximum emission level. The EUT was positioned such that the distance from antenna to the EUT was 10 meters.

The antenna can move up and down between 1 meter and 4 meters to find out the maximum emission level.

Both horizontal and vertical polarization of the antenna are set on measurement. In order to find the maximum emission, all of the interface cables must be manipulated according to EN55022:1998 on radiated measurement.

Radiated emissions were investigated over the frequency range from 30MHz to 1GHz using a receiver bandwidth of 120kHz. Radiated was performed at an antenna to EUT distance of 10 meters.

3.5. Test Specification

According to EN 55022:1998

3.6. Test Result

The emission from the EUT was below the specified limits. The worst-case emissions are shown in section 13. The acceptance criterion was met and the EUT passed the test.

4. Power Harmonics and Voltage Fluctuation

4.1. Power Harmonics and Voltage Fluctuation Test Equipment List

Item	Instrument	Manufacturer	Type No/Serial No.	Last Calibration
1	Power Harmonics Tester	SCHAFFNER	Proflin 2105-400 S/N: HK54148	Jun., 2002
2	Analyzer	SCHAFFNER	CCN 1000-1/X71887	Jun., 2002
3	No.3 Shielded Room			N/A

Note: All equipment upon which need to calibrated are with calibration period of 1 year.

4.2. Test Setup

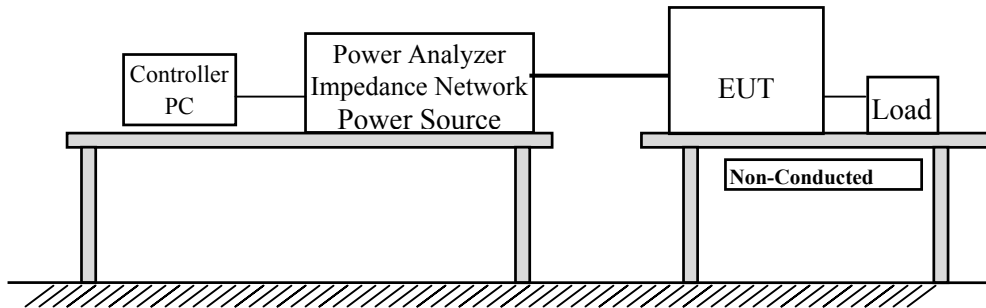

4.3. Limits

➤Limits of Harmonics Currents

Harmonics Order	Maximum Permissible harmonic current (in amperes)	Harmonics Order	Maximum Permissible harmonic current (in amperes)
Odd harmonics		Even harmonics	
3	2.30	2	1.08
5	1.14	4	0.43
7	0.77	6	0.30
9	0.40	8 ≤ n ≤ 40	0.23 * 8/n
11	0.33		
13	0.21		
15 ≤ n ≤ 39	0.15 * 15/n		

4.4. Test Procedure

The EUT is supplied in series with power analyzer from a power source having the same normal voltage and frequency as the rated supply voltage and the equipment under test. And the rated voltage at the supply voltage of EUT of 0.94 times and 1.06 times shall be performed.

4.5. Test Specification

According to EN 61000-3-2:1995, , Amendment 1:1998, Amendment 2:1998 and EN 61000-3-3:1995

4.6. Test Result

The measurement of the power harmonics, which test at the extremes of EUT's supply range, was investigated and test result was shown in section 13. The acceptance criterion was met and the EUT passed the test.

5. Electrostatic Discharge (ESD)

5.1. Test Equipment

Item	Instrument	Manufacturer	Type No/Serial No.	Last Calibration
1	ESD Simulator System	Key Tek	MZ-15/ZC 0112372	Jun., 2002
2	Horizontal Coupling Plane(HCP)	Quietek	HCP AL50	Jun., 2002
3	Vertical Coupling Plane(VCP)	Quietek	VCP AL50	Jun., 2002
4	No.3 Shielded Room			N/A

Note: All equipment upon which need to calibrated are with calibration period of 1 year.

5.2. Test Setup

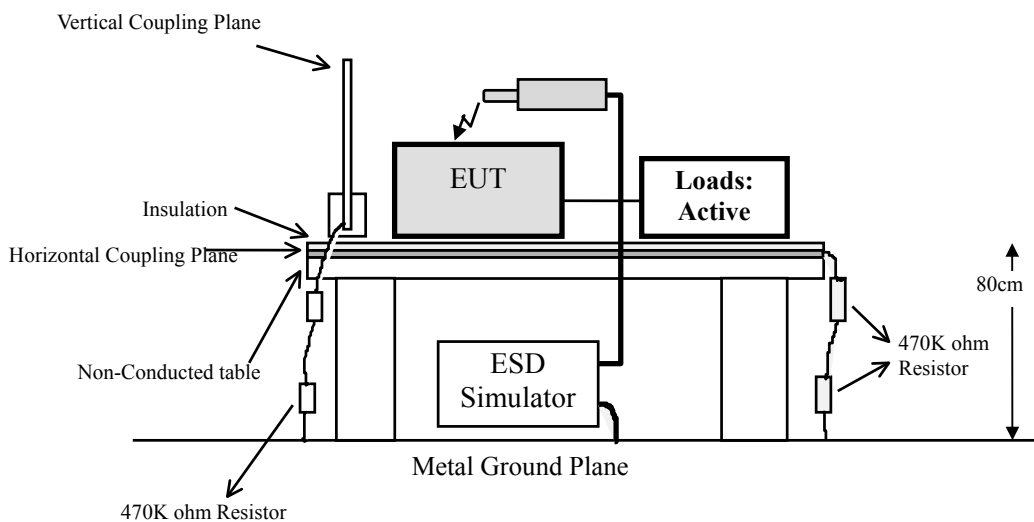

5.3. Test Level

Item	Environmental Phenomena	Units	Test Specification	Performance Criteria
Enclosure Port				
	Electrostatic Discharge	kV(Charge Voltage)	± 8 Air Discharge ± 4 Contact Discharge	B

Remark:

The Contact discharges were applied – at least total 200 discharges at a minimum of four test points.

5.4. Test Procedure

Direct application of discharges to the EUT:

Contact discharge was applied only to conductive surfaces of the EUT.

Air discharges were applied only to non-conductive surfaces of the EUT.

During the test, it was performed with single discharges. For the single discharge time between successive single discharges will be keep longer 1 second. It was at least ten single discharges with positive and negative at the same selected point.

The selected point, which was performed with electrostatic discharge, was marked on the red label of the EUT.

Indirect application of discharges to the EUT:

Vertical Coupling Plane (VCP):

The coupling plane, of dimensions 0.5m x 0.5m, is placed parallel to, and positioned at a distance 0.1m from, the EUT, with the Discharge Electrode touching the coupling plane.

The four faces of the EUT will be performed with electrostatic discharge. It was at least ten single discharges with positive and negative at the same selected point.

Horizontal Coupling Plane (HCP):

The coupling plane is placed under to the EUT. The generator shall be positioned vertically at a distance of 0.1m from the EUT, with the Discharge Electrode touching the coupling plane.

The four faces of the EUT will be performed with electrostatic discharge. It was at least ten single discharges with positive and negative at the same selected point.

5.5. Test Specification

According to IEC 61000-4-2:1995

5.6. Test Result

The measurement of the electrostatic discharge was investigated and test result was shown in section 13. The acceptance criterion was met and the EUT passed the test.

6. Radiated Susceptibility (RS)

6.1. Test Equipment

Item	Instrument	Manufacturer	Type No/Serial No.	Last Calibration
1	Signal Generator	IFR	2023B / 202302/581	May, 2002
2	Power Amplifier	A & R	500A100AM3 /29369	Aug., 2001
3	Power Amplifier	SCHAFFNER	CBA9413B / 0006	Jun., 2002
4	Field Strength Sensor	SCHAFFNER	EMC 20 / Y-0028/ Z-0003	Jun., 2002
5	Power Antenna	SCHWARZBECK	VULB 9166 / 1073	Sep., 2001
6	Power Meter	BOONTON	4232A / 42201	May, 2002
7	No.2 EMC Fully Chamber			July, 2002

Note: All equipment upon which need to calibrated are with calibration period of 1 year.

6.2. Test Setup

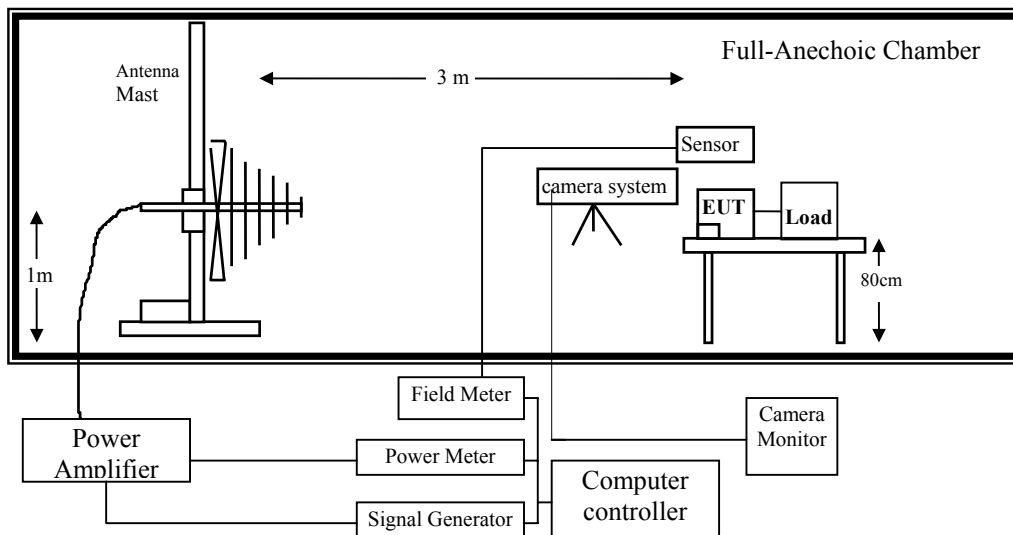

6.3. Test Level

Item	Environmental Phenomena	Units	Test Specification	Performance Criteria
Enclosure Port				
	Radio-Frequency	MHz	80-1000	
	Electromagnetic Field	V/m(Un-modulated, rms)	3	A
	Amplitude Modulated	% AM (1kHz)	80	

6.4. Test Procedure

The EUT and load, which are placed on a table that is 0.8 meter above ground, are placed with one coincident with the calibration plane such that the distance from antenna to the EUT was 3 meters.

Both horizontal and vertical polarization of the antenna and four sides of the EUT are set on measurement.

In order to judge the EUT performance, a CCD camera is used to monitor EUT screen.

All the scanning conditions are as follows:

Condition of Test	Remarks
EN 55024:1998	
1. Field Strength	3 V/M Level 2
2. Radiated Signal	AM 80% Modulated with 1kHz
3. Scanning Frequency	80MHz - 1000MHz
4 Dwell Time	3 Seconds
5. Frequency step size Δf :	1%
6. The rate of Swept of Frequency	1.5×10^{-3} decades/s

6.5. Test Specification

According to IEC 61000-4-3:1995

6.6. Test Result

The measurement of the radiated susceptibility was investigated and test result was shown in section 13. The acceptance criterion was met and the EUT passed the test.

7. Electrical Fast Transient/Burst (EFT/B)

7.1. Test Equipment

Item	Instrument	Manufacturer	Type No/Serial No.	Last Calibration
1	Fast Transient/Burst Generator	SCHAFFNER	BEST S/N: 300035-008SC	Jun., 2002
2	No.3 Shielded Room			N/A

Note: All equipment upon which need to calibrated are with calibration period of 1 year.

7.2. Test Setup

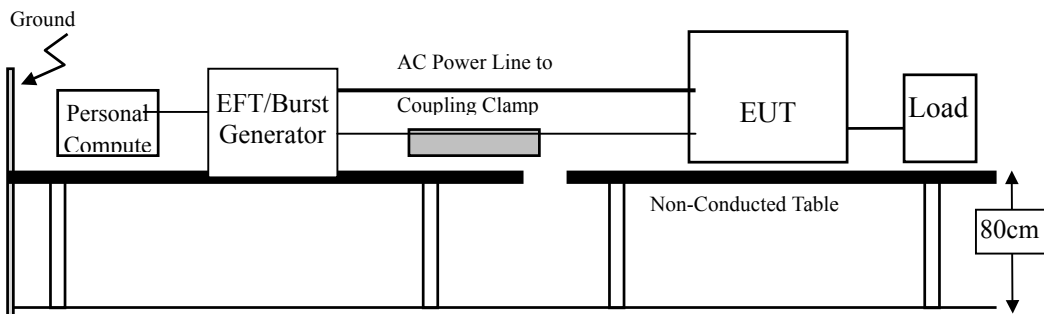

7.3. Test Level

Item	Environmental Phenomena	Units	Test Specification	Performance Criteria
Signal Ports and Telecommunication Ports				
	Fast Transients Common Mode	kV (Peak) Tr/Ts ns Rep. Frequency kHz	± 0.5 5/50 5	B
Input DC Power Ports				
	Fast Transients Common Mode	kV (Peak) Tr/Ts ns Rep. Frequency kHz	± 0.5 5/50 5	B
Input AC Power Ports				
	Fast Transients Common Mode	kV (Peak) Tr/Ts ns Rep. Frequency kHz	± 1 5/50 5	B

7.4. Test Procedure

The EUT and load are placed on a table that is 0.8 meter above a metal ground plane measured 1m*1m min. and 0.65mm thick min. And projected beyond the EUT by at least 0.1m on all sides.

For Signal Ports and Telecommunication Ports:

The EFT interference signal is through a coupling clamp device couples to the signal and control lines of the EUT with burst noise for 1min.

For Input DC and AC Power Ports:

The EUT is connected to the power mains through a coupling device that directly couples the EFT interference signal.

Each of the Line and Neutral conductors is impressed with burst noise for 1 min.

The length of power cord between the coupling device and the EUT shall be 1m.

7.5. Test Specification

According to IEC 61000-4-4:1995

7.6. Test Result

The measurement of the Electrical Fast Transient/Burst was investigated and test result was shown in section 13. The acceptance criterion was met and the EUT passed the test.

8. Surge

8.1. Test Equipment

Note: All equipment upon which need to calibrated are with calibration period of 1 year.

8.2. Test Setup

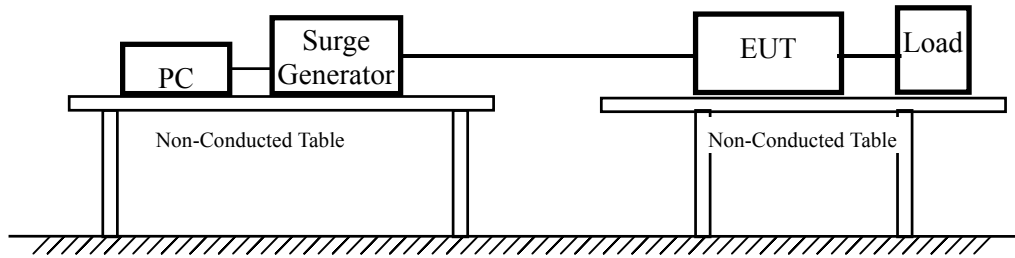

8.3. Test Level

Item	Environmental Phenomena	Units	Test Specification	Performance Criteria
Signal Ports and Telecommunication Ports				
	Surges	Tr/Ts uS	1.2/50 (8/20)	
	Line to Ground	KV	± 1	B
Input DC Power Ports				
	Surges	Tr/Ts uS	1.2/50 (8/20)	
	Line to Ground	kV	± 0.5	B
AC Input and AC Output Power Ports				
	Surges	Tr/Ts uS	1.2/50 (8/20)	
	Line to Line	kV	± 1	B
	Line to Ground	kV	± 2	

Notes:

- 1) Applicable only to ports which according to the manufacturer's may directly to outdoor cables.
- 2) Where normal functioning cannot be achieved because of the impact of the CDN on the EUT, no test shall be required.

8.4. Test Procedure

The EUT and its load are placed on a table that is 0.8 meter above a metal ground plane measured 1m*1m min. and 0.65mm thick min. And projected beyond the EUT by at least 0.1m on all sides. The length of power cord between the coupling device and the EUT shall be 2m or less.

For Input and Output AC Power or DC Input and DC Output Power Ports:

The EUT is connected to the power mains through a coupling device that directly couples the Surge interference signal.

The surge noise shall be applied synchronized to the voltage phase at 0° , 90° , 180° , 270° and the peak value of the a.c. voltage wave. (Positive and negative)

Each of Line-Earth and Line-Line is impressed with a sequence of five surge voltages with interval of 1 min.

8.5. Test Specification

According to IEC 61000-4-5:1995

8.6. Test Result

The measurement of the Surge was investigated and test result was shown in section 13. The acceptance criterion was met and the EUT passed the test.

9. Conducted Susceptibility (CS)

9.1. Test Equipment

Item	Instrument	Manufacturer	Type No/Serial No.	Last Calibration
1	Signal Generator	IFR	2023B / 202302/581	May, 2002
2	Power Amplifier	A & R	500A100AM3 /29369	Aug., 2001
3	Power Amplifier	SCHAFFNER	CBA9413B / 0006	Jun., 2002
4	CDN 1	Schwarzbeck	L801 M2/3 / 1549	Jun., 2002
5	CDN 2	Schwarzbeck	L801 S1 / 1574	Jun., 2002
6	50 ohm Terminator	RES-NET	RCX6BM	Jun., 2002
7	6dB Attenuator	BIRD	RFA250NFF10	Jun., 2002
8	EM Clamp	Schwarzbeck	KEMZ 801 / 15928	Jun., 2002
9	No.2 EMC Fully Chamber			N/A

Note: All equipment upon which need to calibrated are with calibration period of 1 year.

9.2. Test Setup

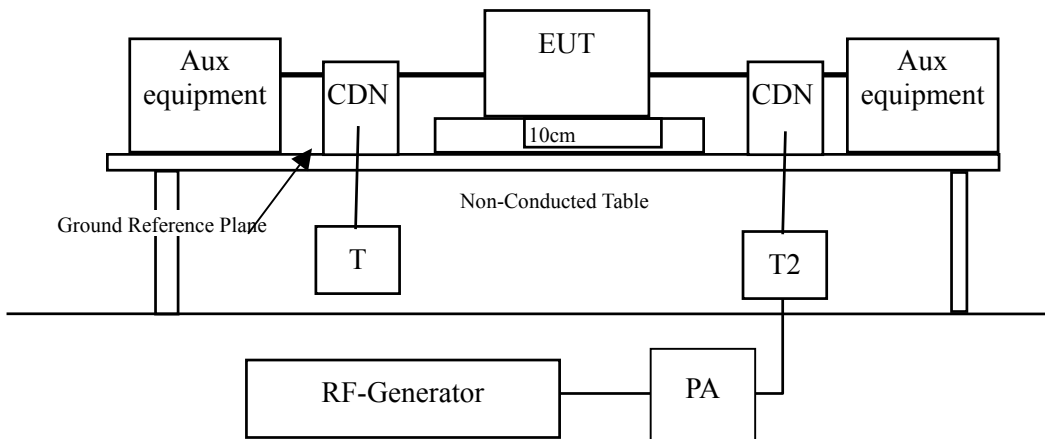

9.3. Test Level

Item	Environmental Phenomena	Units	Test Specification	Performance Criteria
Signal Ports and Telecommunication Ports				
	Radio-Frequency	MHz	0.15-80	
	Continuous Conducted	V (rms, Un-modulated)	3	A
		% AM (1kHz)	80	
Input DC Power Ports				
	Radio-Frequency	MHz	0.15-80	
	Continuous Conducted	V (rms, Un-modulated)	3	A
		% AM (1kHz)	80	
Input AC Power Ports				
	Radio-Frequency	MHz	0.15-80	
	Continuous Conducted	V (rms, Un-modulated)	3	A
		% AM (1kHz)	80	

9.4. Test Procedure

The EUT are placed on a table that is 0.8 meter height, and a Ground reference plane on the table, EUT are placed upon table and use a 10cm insulation between the EUT and Ground reference plane.

For Signal Ports and Telecommunication Ports

The disturbance signal is through a coupling and decoupling networks (CDN) or EM-clamp device couples to the signal and Telecommunication lines of the EUT.

For Input DC and AC Power Ports

The EUT is connected to the power mains through a coupling and decoupling networks for power supply lines. And directly couples the disturbances signal into EUT.

Used CDN-M2 for two wires or CDN-M3 for three wires.

All the scanning conditions are as follows:

Condition of Test	Remarks
1. Field Strength	130dBuV(3V) Level 2
2. Radiated Signal	AM 80% Modulated with 1kHz
3. Scanning Frequency	0.15MHz – 80MHz
4 Dwell Time	3 Seconds
5. Frequency step size Δf :	1%
6. The rate of Swept of Frequency	1.5×10^{-3} decades/s

9.5. Test Specification

According to IEC 61000-4-6:1996

9.6. Test Result

The measurement of the Conducted Susceptibility was investigated and test result was shown in section 13. The acceptance criterion was met and the EUT passed the test.

10. Power Frequency Magnetic Field

10.1. Test Equipment

Item	Instrument	Manufacturer	Type No/Serial No.	Last Calibration
1	Voltage Dips Generator	Haefely	PLINE 1610 S/N: 080 938-05	Jun., 2002
2	Gauss Meter	F.W.BELL	4090	Jun., 2002
3	No.3 Shielded Room			N/A

Note: All equipment upon which need to calibrated are with calibration period of 1 year.

10.2. Test Setup

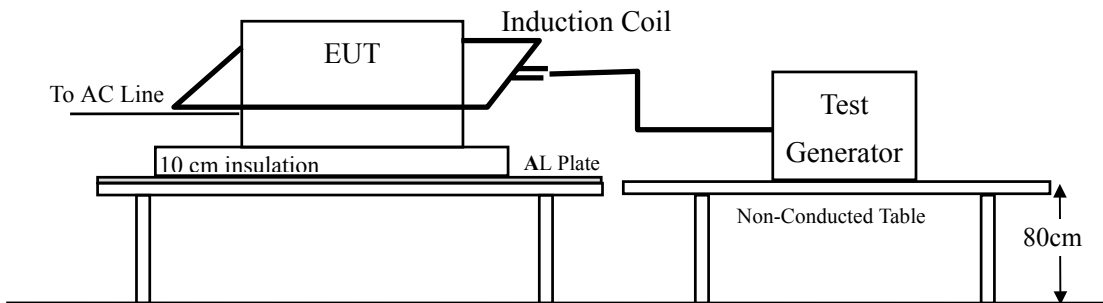

10.3. Test Level

Item	Environmental Phenomena	Units	Test Specification	Performance Criteria
Enclosure Port				
	Power-Frequency Magnetic Field	Hz A/m (r.m.s.)	50 1	A

10.4. Test Procedure

The EUT and its load are placed on a table which is 0.8 meter above a metal ground plane measured at least 1m*1m min. The test magnetic field shall be placed at central of the induction coil.

The test magnetic Field shall be applied 10minutes by the immersion method to the EUT. And the induction coil shall be rotated by 90° in order to expose the EUT to the test field with different orientation (X, Y, Z Orientations).

10.5. Test Specification

According to IEC 61000-4-8:1993

10.6. Test Result

The measurement of the Power Frequency Magnetic Field was investigated and test result was shown in section 13. The acceptance criterion was met and the EUT passed the test.

11. Voltage Dips and Interruption Measurement

11.1. Test Equipment

Item	Instrument	Manufacturer	Type No/Serial No.	Last Calibration
1	Voltage Dips Generator	Haefely	PLINE 1610 S/N: 080 938-05	Jun., 2002
2	No.3 Shielded Room			N/A

Note: All equipment upon which need to calibrated are with calibration period of 1 year.

11.2. Test Setup

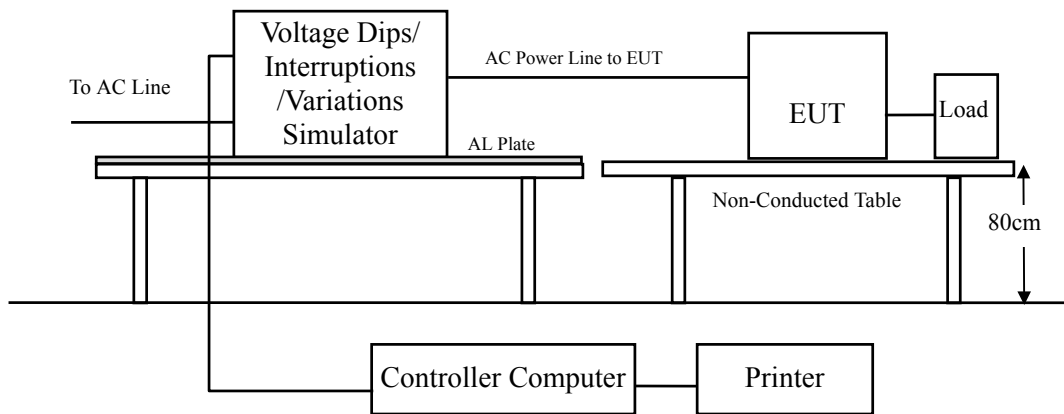

11.3. Test Level

Item	Environmental Phenomena	Units	Test Specification	Performance Criteria
Input AC Power Ports				
Voltage Dips		% Reduction	>95	B
		Period	0.5	
		% Reduction	30	C
Periods	25			
Voltage Interruptions		% Reduction	> 95	C
		Periods	250	

11.4. Test Procedure

The EUT and its load are placed on a table which is 0.8 meter above a metal ground plane measured 1m*1m min. And 0.65mm thick min. And projected beyond the EUT by at least 0.1m on all sides. The power cord shall be used the shortest power cord as specified by the manufacturer.

For Voltage Dips/ Interruptions test:

The selection of test voltage is based on the rated power range. If the operation range is large than 20% of lower power range, both end of specified voltage shall be tested. Otherwise, the typical voltage specification is selected as test voltage.

The EUT is connected to the power mains through a coupling device that directly couples to the Voltage Dips and Interruption Generator.

The EUT shall be tested for 30% voltage dip of supplied voltage and duration 10ms, for 60% voltage dip of supplied voltage and duration 100ms with a sequence of three voltage dips with intervals of 10 seconds, and for 95% voltage interruption of supplied voltage and duration 5000ms with a sequence of three voltage interruptions with intervals of 10 seconds. Voltage phase shifting are shall occur at 0° , 45° , 90° , 135° , 180° , 225° , 270° , 315° of the voltage.

11.5. Test Specification

According to IEC 61000-4-11:1994

11.6. Test Result

The measurement of the Voltage Dips and Interruption was investigated and test result was shown in section 13. The acceptance criterion was met and the EUT passed the test.

12. EMC Reduction Method During Compliance Testing

No modification was made during testing.

13. Test Result

The test results in the emission and the immunity were performed according to the requirements of measurement standard and process. Quietek Corporation is assumed full responsibility for the accuracy and completeness of these measurements. The test data of the emission is listed as below.

All the tests were carried out with the EUT in normal operation, which was defined as:

EMI Test	:	Mode 1: 1920*1440/75Hz (D-SUB+DVI) Mode 2: 1600*1200/85Hz (D-SUB+S-Video) Mode 3: 1024*768/60Hz (DVI+AV)
EMS Test	:	Mode 1: 1920*1440/75Hz (D-SUB+DVI)

Note :

- No Deviation from standard procedure
- Deviations from standard procedure

13.1. Test Data of Conducted Emission

Date of Test	Jul. 16, 2002	Test Room	No.4 Shielded Room
Test Mode	Mode 1: 1920*1440/75Hz (D-SUB+DVI)	Product	VGA Card
Test Condition	Line1 & Line2	Test Range	0.15MHz – 30MHz

Frequency MHz	Measurement Level (dBuV)				Limits (dBuV)	
	Line1 QP	Line1 AV	Line2 QP	Line2 AV	QP	AV
0.167	--	--	47.41	44.01	65.11	55.11
0.168	38.81	36.41	--	--	65.06	55.06
0.233	35.11	33.41	--	--	62.34	52.34
0.233	--	--	40.11	35.11	62.34	52.34
0.301	24.41	22.41	--	--	60.22	50.22
0.301	--	--	35.91	31.41	60.22	50.22
0.365	--	--	30.91	26.81	58.61	48.61
0.366	24.51	22.51	--	--	58.59	48.59
0.436	--	--	24.91	21.11	57.14	47.14
15.631	28.28	22.28	--	--	60.00	50.00
19.134	29.18	21.48	--	--	60.00	50.00
19.342	--	--	29.18	21.38	60.00	50.00

Note:

1. All Reading Levels are Quasi-Peak and average value.
2. Measurement Level = Reading Level + LISN Factor + Cable loss.
3. "--", means the average measurement was not performed when the Quasi-peak measured data under the limit of average detection.

Quietek Corporation
EMI Test Receiver ECCS 30

EUT: VGA CARD
Manuf: ASUS
Op Cond: Full System
Operator: Eddie
Test Spec: AC 230V/50Hz
Comment: Line 1
M/N: V8420 (Mode:1)
Date: 14. Jul 02 18:37

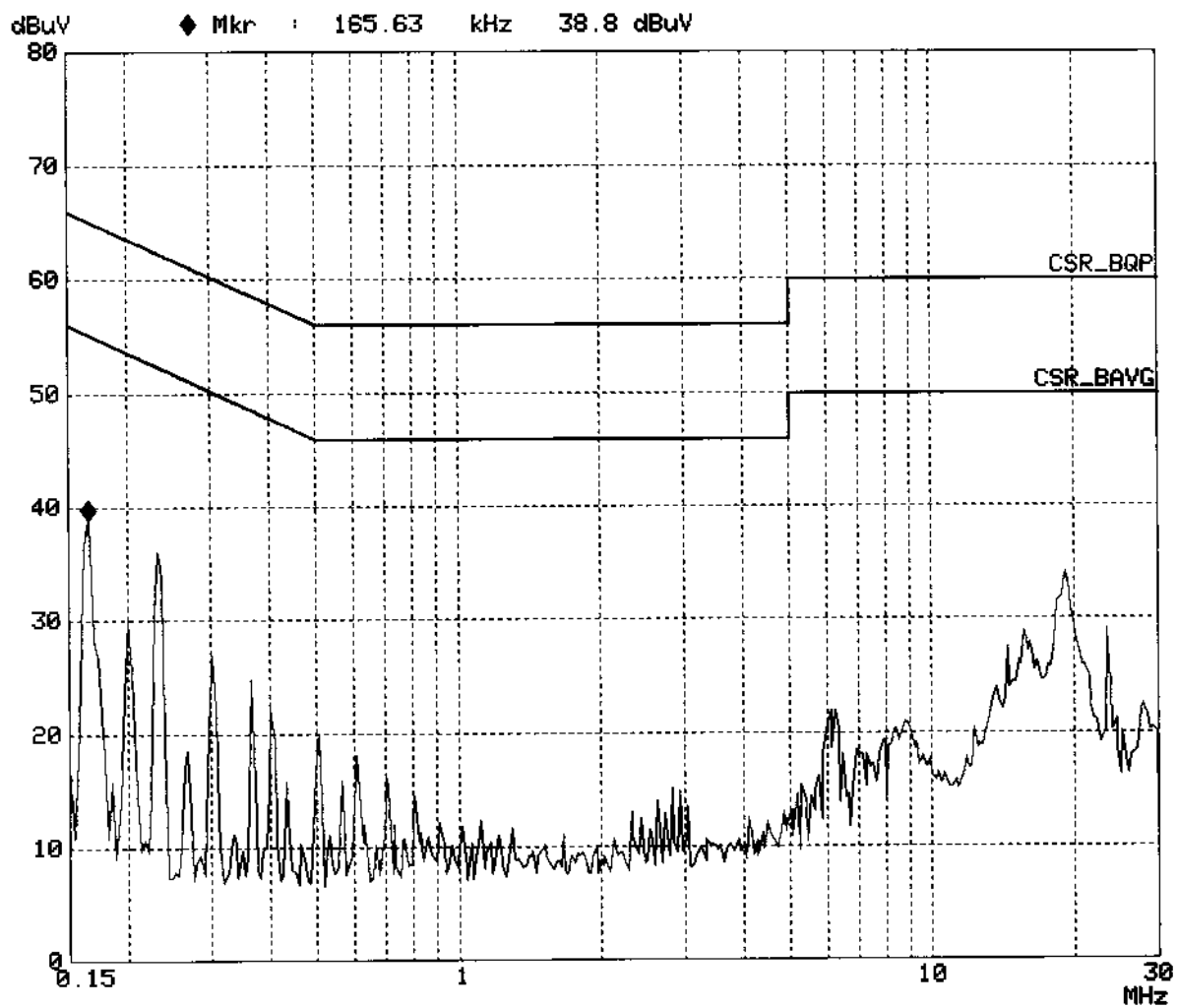

Quietek Corporation
EMI Test Receiver ECCS 30

EUT: VGA CARD
Manuf: ASUS
Op Cond: Full System
Operator: Eddie
Test Spec: AC 230V/50Hz
Comment: Line 2
M/N: V8420 (Mode:1)
Date: 14. Jul 02 18:57

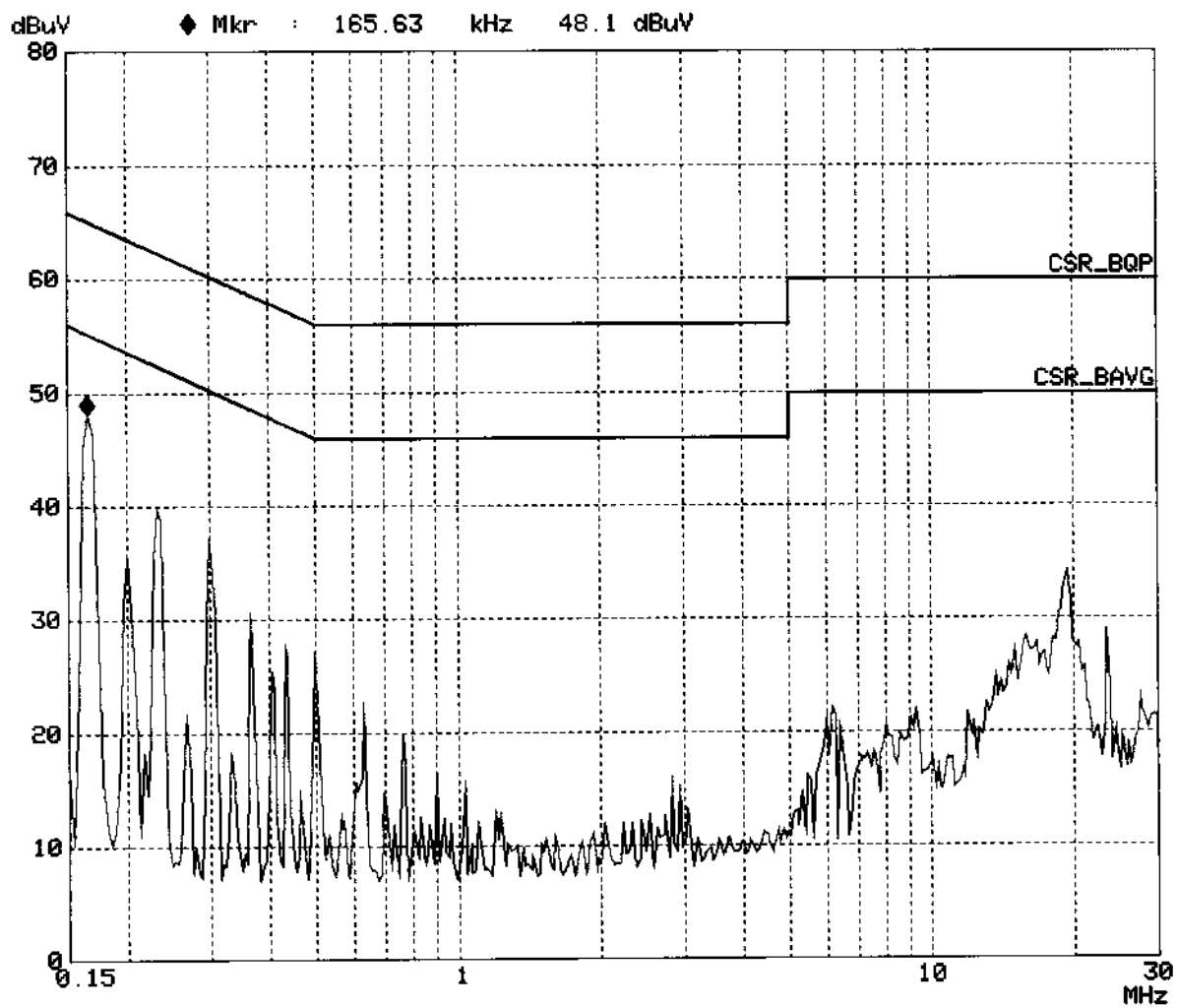

Date of Test	Jul. 16, 2002	Test Room	No.4 Shielded Room
Test Mode	Mode 2: 1600*1200/85Hz (D-SUB+S-Video)	Product	VGA Card
Test Condition	Line1 & Line2	Test Range	0.15MHz – 30MHz

Frequency MHz	Measurement Level (dBuV)				Limits (dBuV)	
	Line1 QP	Line1 AV	Line2 QP	Line2 AV	QP	AV
0.167	38.91	36.51	--	--	65.11	55.11
0.167	--	--	47.31	43.91	55.11	45.11
0.200	27.41	23.81	--	--	63.61	53.61
0.234	34.61	32.91	--	--	62.31	52.31
0.234	--	--	39.91	34.91	52.31	42.31
0.300	--	--	35.61	30.91	50.24	40.24
0.301	24.81	23.01	--	--	60.22	50.22
0.364	--	--	30.91	26.61	48.64	38.64
15.635	28.58	23.68	--	--	60.00	50.00
15.642	--	--	27.98	24.38	50.00	40.00
19.180	28.68	20.78	--	--	60.00	50.00
19.577	--	--	28.69	20.09	50.00	40.00

Note:

1. All Reading Levels are Quasi-Peak and average value.
2. Measurement Level = Reading Level + LISN Factor + Cable loss.
3. "--", means the average measurement was not performed when the Quasi-peak measured data under the limit of average detection.

Quietek Corporation
EMI Test Receiver ECCS 30

EUT: VGA CARD
Manuf: ASUS
Op Cond: Full System
Operator: Eddie
Test Spec: AC 230V/50Hz
Comment: Line 1
M/N: V8420 (Mode:2)
Date: 14. Jul 02 18:26

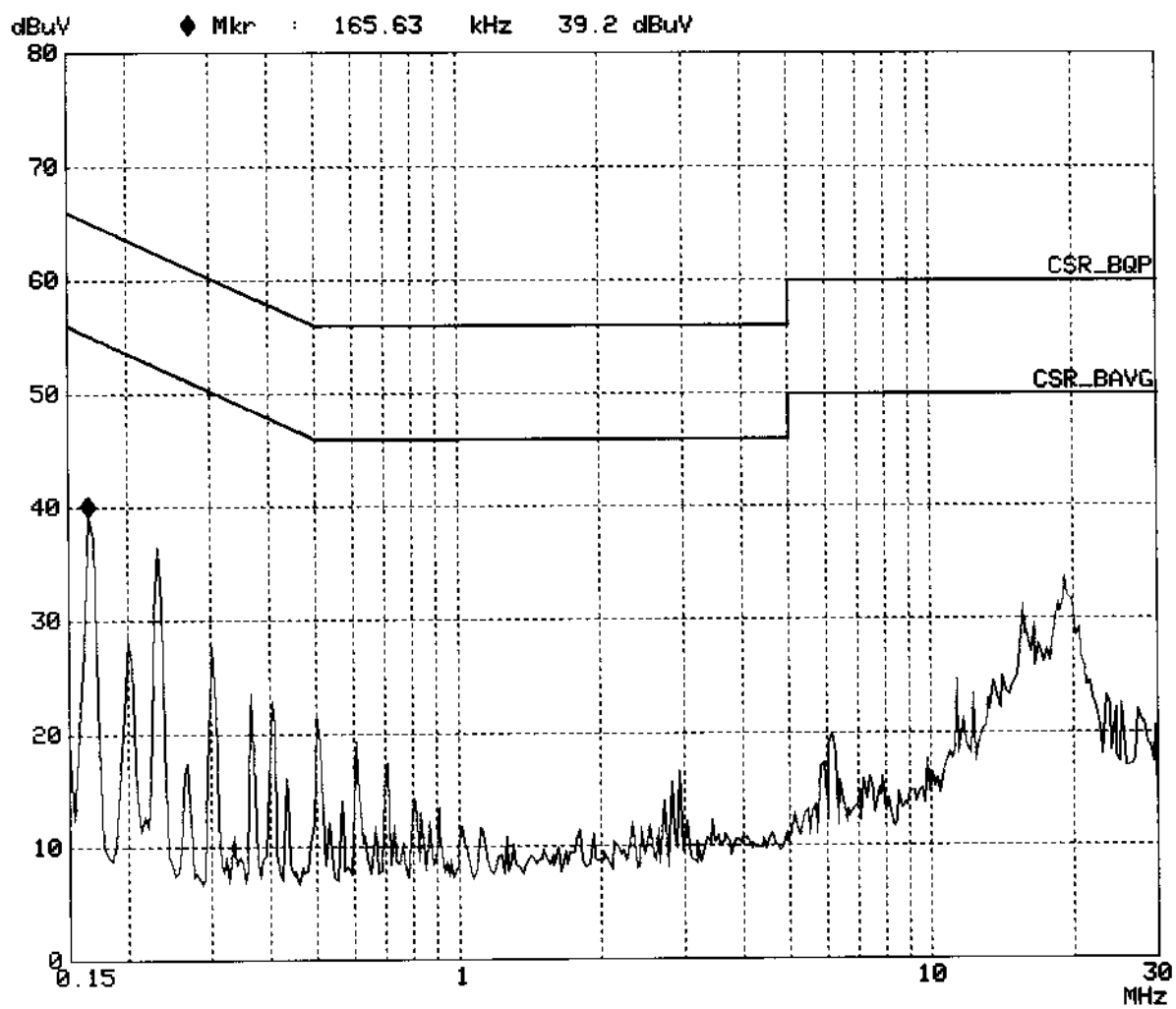

Quietek Corporation
EMI Test Receiver ECCS 30

EUT: VGA CARD
Manuf: ASUS
Op Cond: Full System
Operator: Eddie
Test Spec: AC 230V/50Hz
Comment: Line 2
M/N: V8420 (Mode:2)
Date: 14. Jul 02 18:30

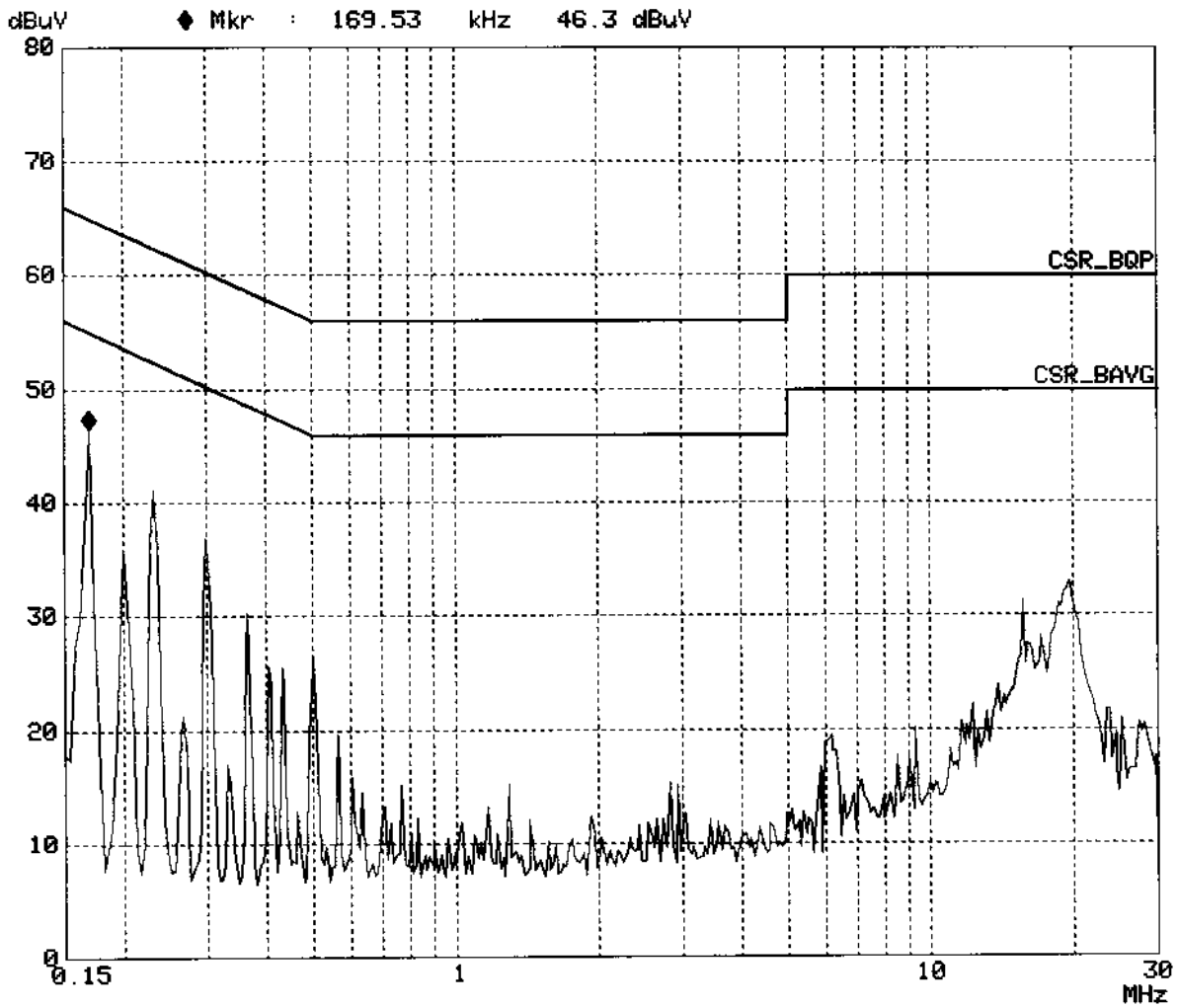

Date of Test	Jul. 16, 2002	Test Room	No.4 Shielded Room
Test Mode	Mode 3: 1024*768/60Hz (DVI+AV)	Product	VGA Card
Test Condition	Line1 & Line2	Test Range	0.15MHz – 30MHz

Frequency MHz	Measurement Level (dBuV)				Limits (dBuV)	
	Line1 QP	Line1 AV	Line2 QP	Line2 AV	QP	AV
0.166	--	--	47.11	43.61	65.16	55.16
0.167	38.01	35.41	--	--	65.11	55.11
0.233	34.81	33.01	--	--	62.34	52.34
0.233	--	--	40.11	35.21	62.34	52.34
0.301	--	--	34.51	30.11	60.22	50.22
0.302	24.41	23.01	--	--	60.19	50.19
0.366	23.91	22.11	--	--	58.59	48.59
0.367	--	--	30.71	26.41	58.57	48.57
15.638	--	--	28.58	25.08	60.00	50.00
15.640	28.98	25.38	--	--	60.00	50.00
19.239	30.48	22.48	--	--	60.00	50.00
19.723	--	--	29.84	21.44	60.00	50.00

Note:

1. All Reading Levels are Quasi-Peak and average value.
2. Measurement Level = Reading Level + LISN Factor + Cable loss.
3. "--", means the average measurement was not performed when the Quasi-peak measured data under the limit of average detection.

Quietek Corporation
EMI Test Receiver ECCS 30

EUT: VGA CARD
Manuf: ASUS
Op Cond: Full System
Operator: Eddie
Test Spec: AC 230V/50Hz
Comment: Line 1
M/N: V8420 (Mode:3)
Date: 14. Jul 02 18:11

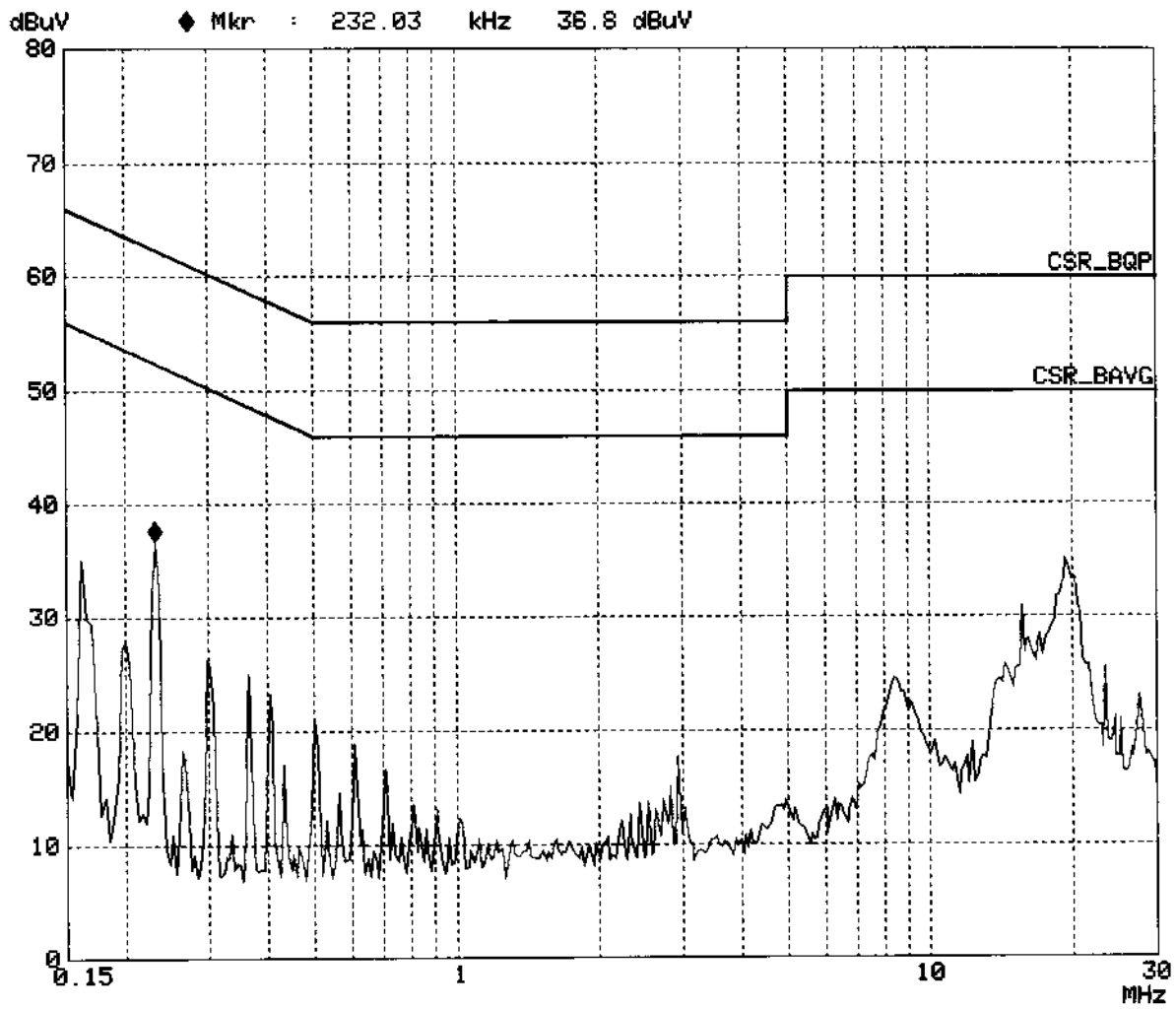

Quietek Corporation
EMI Test Receiver ECCS 30

EUT: VGA CARD
Manuf: ASUS
Op Cond: Full System
Operator: Eddie
Test Spec: AC 230V/50Hz
Comment: Line 2
M/N: V8420 (Mode:3)
Date: 14. Jul 02 18:17

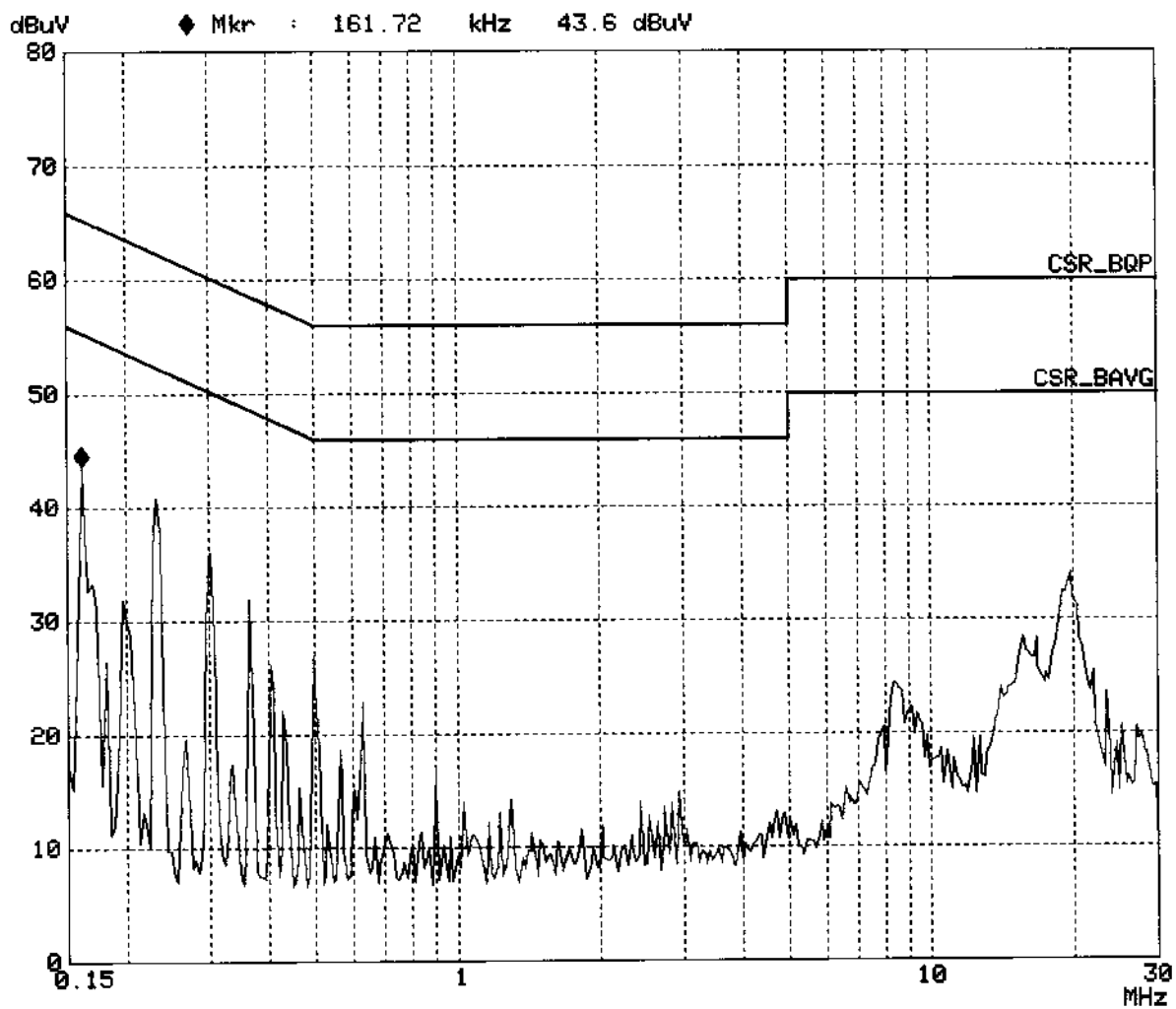

13.2. Test Data of Radiated Emission

Date of Test	Jul. 16, 2002	Test Site	No.3 OATS
Test Mode	Mode 1: 1920*1440/75Hz (D-SUB+DVI)	Product	VGA Card
Test Condition	10m & Horizontal	Test Range	30MHz – 1GHz

Frequency MHz	Cable Loss (dB)	Probe Factor (dB/m)	Pre-Amp Factor (dB)	Reading Level (dBuV/m)	Emission Level (dBuV/m)	Margin (dB)	Limit (dBuV/m)
51.290	0.98	7.43	0.00	5.59	14.00	-16.00	30.00
67.690	1.06	5.99	0.00	13.05	20.10	-9.90	30.00
134.999	1.41	11.59	0.00	9.18	22.18	-7.82	30.00
179.745	1.64	8.27	0.00	11.72	21.63	-8.37	30.00
184.902	1.67	7.98	0.00	12.71	22.36	-7.64	30.00
208.250	1.79	8.46	0.00	10.94	21.19	-8.81	30.00
252.333	2.01	12.04	0.00	9.97	24.02	-12.98	37.00
383.970	2.69	14.01	0.00	10.72	27.42	-9.58	37.00
649.686	4.06	18.64	0.00	4.97	27.67	-9.33	37.00
779.615	4.73	19.03	0.00	7.10	30.86	-6.14	37.00
909.557	5.40	19.54	0.00	7.87	32.81	-4.19	37.00
998.997	5.87	20.89	0.00	6.77	33.53	-3.47	37.00

Note:

1. All Reading Levels below 1GHz are Quasi-Peak.
2. Emission Level = Reading Level + Probe Factor + Cable loss – Preamp.
3. Margin = Emission Level-Limit.

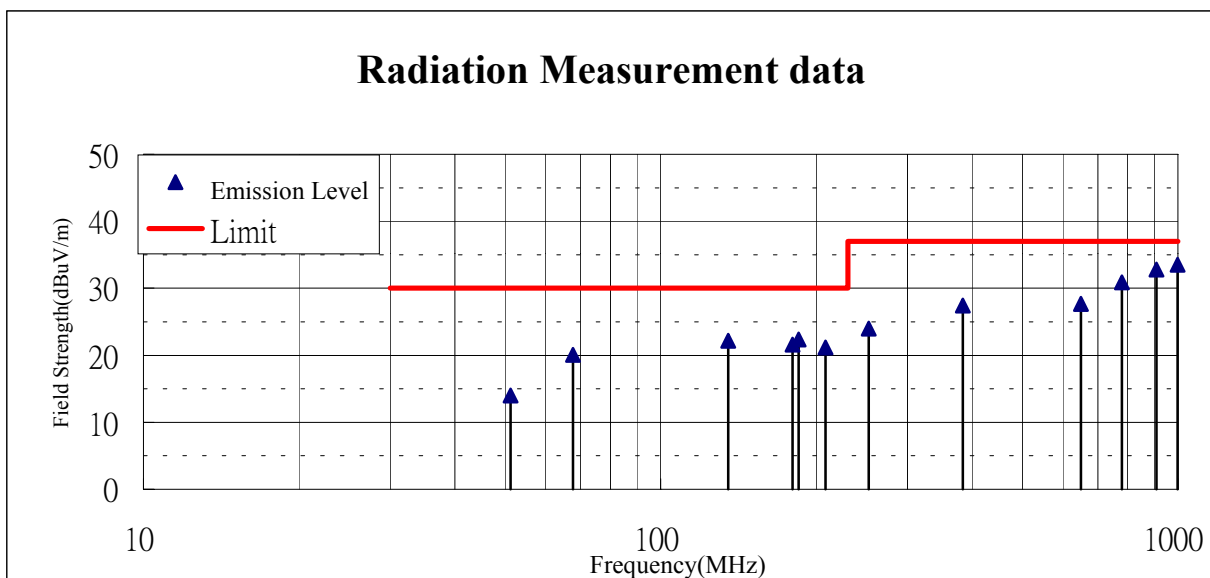

Date of Test	Jul. 16, 2002	Test Site	No.3 OATS
Test Mode	Mode 1: 1920*1440/75Hz (D-SUB+DVI)	Product	VGA Card
Test Condition	10m & Vertical	Test Range	30MHz – 1GHz

Frequency MHz	Cable Loss (dB)	Probe Factor (dB/m)	Pre-Amp Factor (dB)	Reading Level (dBuV/m)	Emission Level (dBuV/m)	Margin (dB)	Limit (dBuV/m)
67.380	1.06	6.07	0.00	10.61	17.74	-12.26	30.00
122.870	1.35	10.73	0.00	9.73	21.81	-8.19	30.00
196.258	1.73	8.14	0.00	9.32	19.19	-10.81	30.00
216.562	1.83	9.26	0.00	9.42	20.51	-9.49	30.00
229.904	1.90	9.73	0.00	9.85	21.48	-8.52	30.00
279.982	2.16	12.19	0.00	14.12	28.47	-8.53	37.00
392.516	2.73	15.57	0.00	8.46	26.76	-10.24	37.00
714.656	4.39	19.08	0.00	6.97	30.44	-6.56	37.00

Note:

1. All Reading Levels below 1GHz are Quasi-Peak.
2. Emission Level = Reading Level + Probe Factor + Cable loss – Preamp.
3. Margin = Emission Level-Limit.

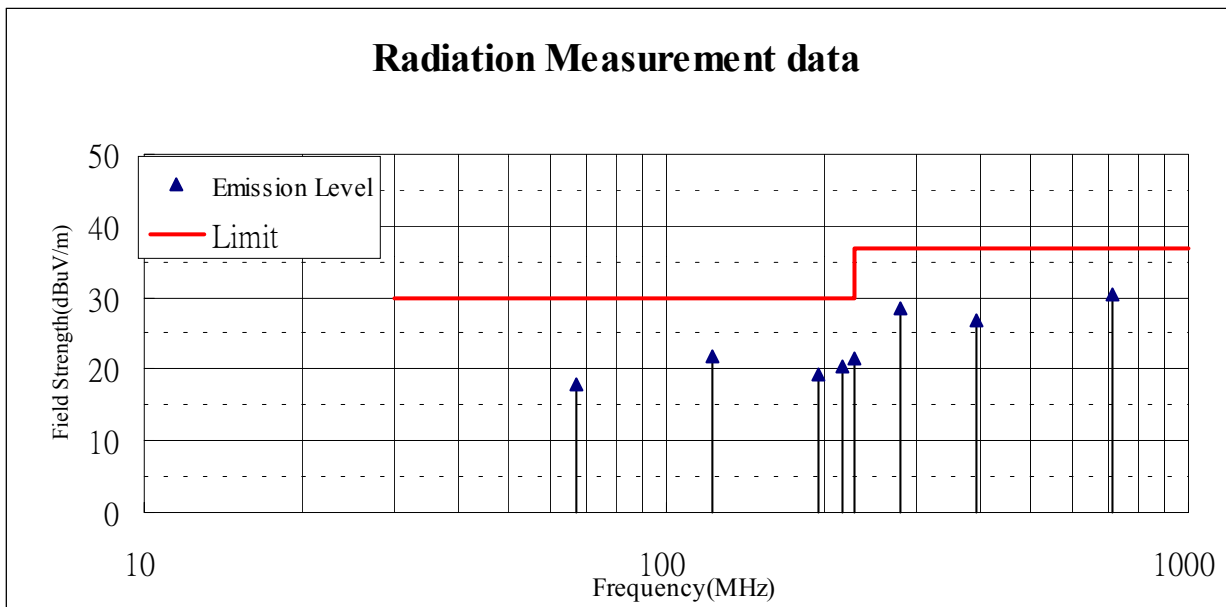

Date of Test	Jul. 16, 2002	Test Site	No.3 OATS
Test Mode	Mode 2: 1600*1200/85Hz (D-SUB+S-Video)	Product	VGA Card
Test Condition	10m & Horizontal	Test Range	30MHz-1GHz

Frequency MHz	Cable Loss (dB)	Probe Factor (dB/m)	Pre-Amp Factor (dB)	Reading Level (dBuV/m)	Emission Level (dBuV/m)	Margin (dB)	Limit (dBuV/m)
55.800	1.00	5.93	0.00	6.84	13.77	-16.23	30.00
69.370	1.07	6.12	0.00	12.02	19.21	-10.79	30.00
142.940	1.45	10.87	0.00	9.16	21.48	-8.52	30.00
176.488	1.62	8.43	0.00	13.11	23.16	-6.84	30.00
216.249	1.83	8.21	0.00	9.47	19.51	-10.49	30.00
262.391	2.06	13.08	0.00	10.90	26.04	-10.96	37.00
327.988	2.4	12.29	0.00	16.55	31.24	-5.76	37.00
393.586	2.74	14.46	0.00	12.34	29.54	-7.46	37.00
459.189	3.08	16.58	0.00	8.64	28.30	-8.70	37.00
524.785	3.42	16.44	0.00	8.07	27.93	-9.07	37.00
655.982	4.10	18.49	0.00	8.49	31.08	-5.92	37.00
787.172	4.77	19.21	0.00	6.96	30.94	-6.06	37.00
918.368	5.45	20.08	0.00	6.61	32.14	-4.86	37.00

Note:

1. All Reading Levels below 1GHz are Quasi-Peak.
2. Emission Level = Reading Level + Probe Factor + Cable loss – Preamp.
3. Margin = Emission Level-Limit.

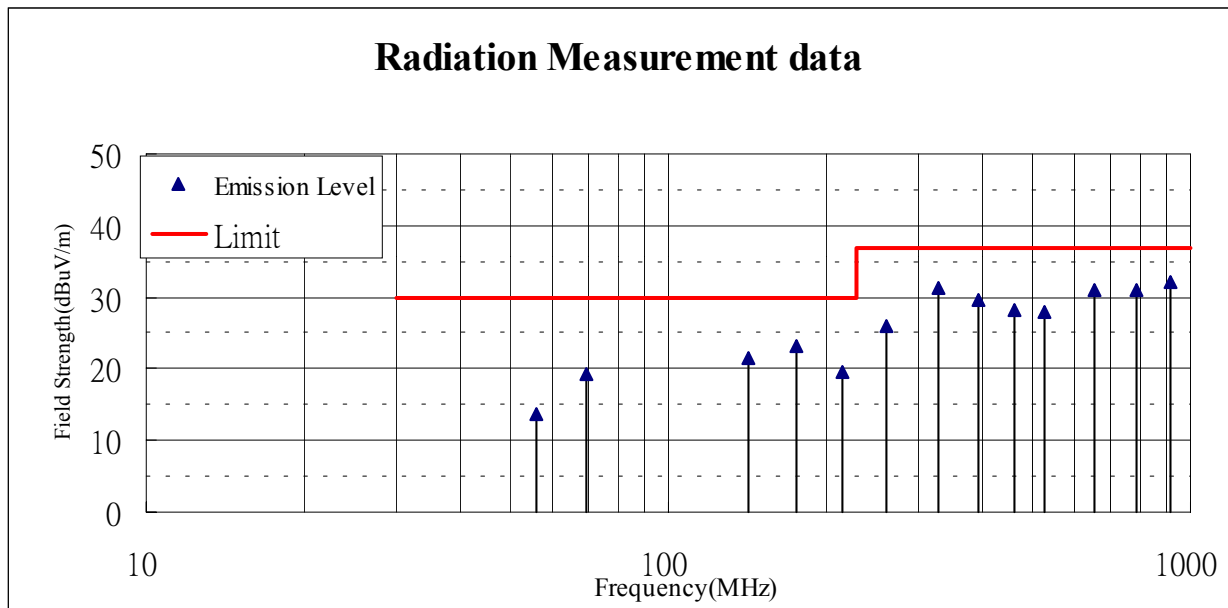

Date of Test	Jul. 16, 2002	Test Site	No.3 OATS
Test Mode	Mode 2: 1600*1200/85Hz (D-SUB+S-Video)	Product	VGA Card
Test Condition	10m & Vertical	Test Range	30MHz – 1GHz

Frequency MHz	Cable Loss (dB)	Probe Factor (dB/m)	Pre-Amp Factor (dB)	Reading Level (dBuV/m)	Emission Level (dBuV/m)	Margin (dB)	Limit (dBuV/m)
43.970	0.94	9.57	0.00	10.41	20.92	-9.08	30.00
53.930	0.99	5.90	0.00	18.32	25.21	-4.79	30.00
70.600	1.08	6.58	0.00	11.90	19.56	-10.44	30.00
176.476	1.62	8.35	0.00	9.13	19.10	-10.90	30.00
196.793	1.73	8.14	0.00	10.88	20.75	-9.25	30.00
215.998	1.83	9.33	0.00	8.34	19.50	-10.50	30.00
262.390	2.06	13.12	0.00	16.14	31.32	-5.68	37.00
327.992	2.40	12.51	0.00	15.02	29.93	-7.07	37.00
393.586	2.74	15.79	0.00	10.51	29.04	-7.96	37.00
459.184	3.08	16.42	0.00	9.32	28.82	-8.18	37.00
655.978	4.10	17.65	0.00	11.24	32.99	-4.01	37.00
787.175	4.77	19.66	0.00	7.28	31.71	-5.29	37.00
918.369	5.45	21.38	0.00	6.58	33.41	-3.59	37.00

Note:

1. All Reading Levels below 1GHz are Quasi-Peak.
2. Emission Level = Reading Level + Probe Factor + Cable loss – Preamp.
3. Margin = Emission Level-Limit.

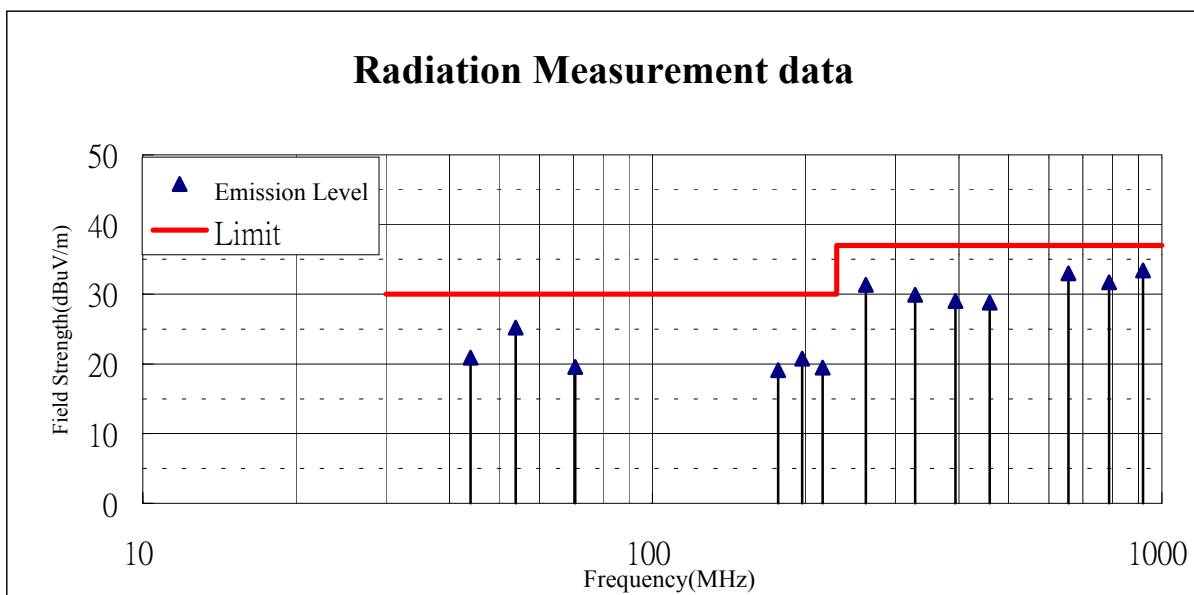

Date of Test	Jul. 16, 2002	Test Site	No.3 OATS
Test Mode	Mode 3: 1024*768/60Hz (DVI+AV)	Product	VGA Card
Test Condition	10m & Horizontal	Test Range	30MHz-1GHz

Frequency MHz	Cable Loss (dB)	Probe Factor (dB/m)	Pre-Amp Factor (dB)	Reading Level (dBuV/m)	Emission Level (dBuV/m)	Margin (dB)	Limit (dBuV/m)
74.140	1.10	7.00	0.00	7.71	15.81	-14.19	30.00
151.593	1.49	10.40	0.00	11.77	23.66	-6.34	30.00
173.251	1.61	8.69	0.00	12.55	22.85	-7.15	30.00
194.909	1.72	8.05	0.00	8.91	18.68	-11.32	30.00
216.565	1.83	8.15	0.00	12.37	22.35	-7.65	30.00
257.722	2.04	12.59	0.00	12.94	27.57	-9.43	37.00
329.314	2.41	12.39	0.00	11.18	25.98	-11.02	37.00
343.635	2.48	12.97	0.00	12.19	27.64	-9.36	37.00
383.980	2.69	14.01	0.00	13.46	30.16	-6.84	37.00
714.654	4.39	18.28	0.00	8.64	31.31	-5.69	37.00
779.619	4.73	19.03	0.00	6.52	30.28	-6.72	37.00
909.563	5.40	19.54	0.00	4.21	29.15	-7.85	37.00

Note:

1. All Reading Levels below 1GHz are Quasi-Peak.
2. Emission Level = Reading Level + Probe Factor + Cable loss – Preamp.
3. Margin = Emission Level-Limit.

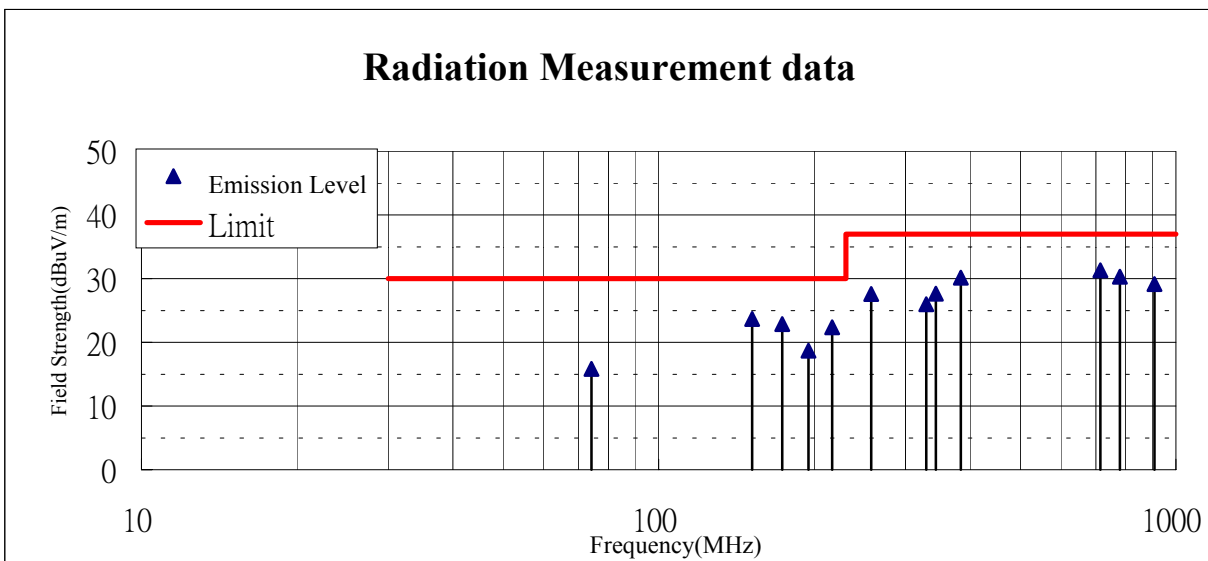

Date of Test	Jul. 16, 2002	Test Site	No.3 OATS
Test Mode	Mode 3: 1024*768/60Hz (DVI+AV)	Product	VGA Card
Test Condition	10m & Vertical	Test Range	30MHz – 1GHz

Frequency MHz	Cable Loss (dB)	Probe Factor (dB/m)	Pre-Amp Factor (dB)	Reading Level (dBuV/m)	Emission Level (dBuV/m)	Margin (dB)	Limit (dBuV/m)
50.620	0.97	6.60	0.00	10.06	17.63	-12.37	30.00
53.700	0.99	6.24	0.00	14.67	21.90	-8.10	30.00
122.888	1.35	10.73	0.00	6.70	18.78	-11.22	30.00
135.351	1.41	10.65	0.00	7.55	19.61	-10.39	30.00
162.419	1.55	8.47	0.00	9.21	19.23	-10.77	30.00
173.250	1.61	8.39	0.00	10.64	20.64	-9.36	30.00
216.563	1.83	9.26	0.00	12.45	23.54	-6.46	30.00
229.088	1.89	9.73	0.00	14.90	26.52	-3.48	30.00
238.218	1.94	10.52	0.00	10.26	22.72	-14.28	37.00
329.312	2.41	12.44	0.00	8.73	23.58	-13.42	37.00
353.701	2.54	13.85	0.00	9.38	25.77	-11.23	37.00
383.990	2.69	15.08	0.00	8.33	26.10	-10.90	37.00

Note:

1. All Reading Levels below 1GHz are Quasi-Peak.
2. Emission Level = Reading Level + Probe Factor + Cable loss – Preamp.
3. Margin = Emission Level-Limit.

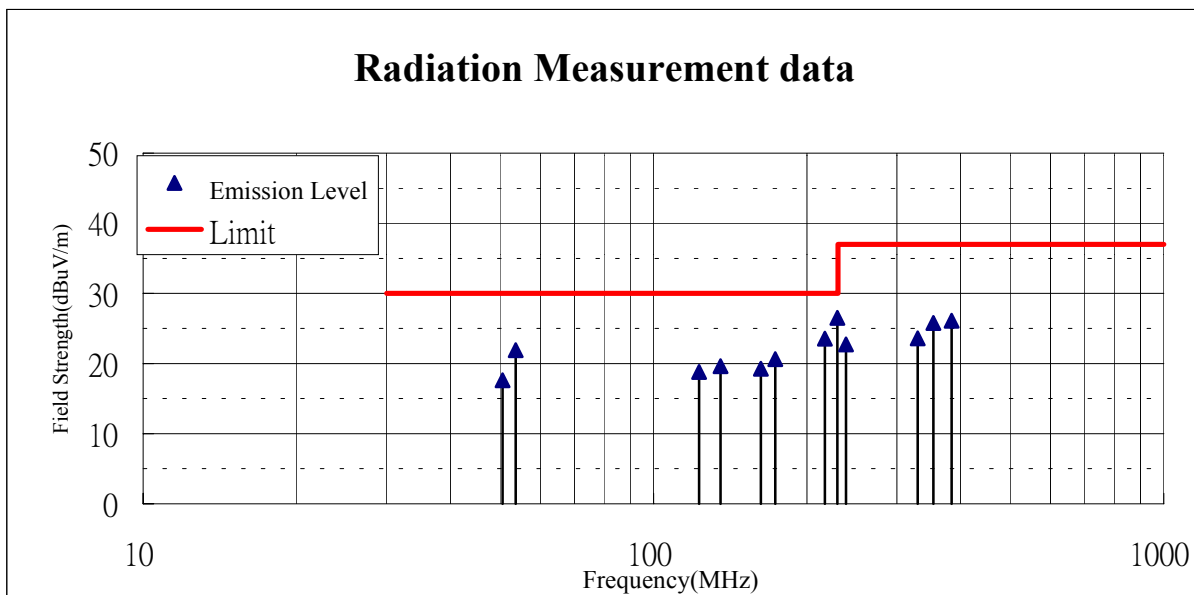

13.3. Test Data of Power Harmonics

Date of Test	Jul. 16, 2002	Test Room	No.3 Shielded Room
Test Mode	Mode 1: 1920*1440/75Hz (D-SUB+DVI)	Product	VGA Card
Test Condition	Power Harmonics (Classification : Class D)		

Test Result: Pass

Source qualification: Normal

Current & voltage waveforms

It is 0.0% outside Class-D envelope

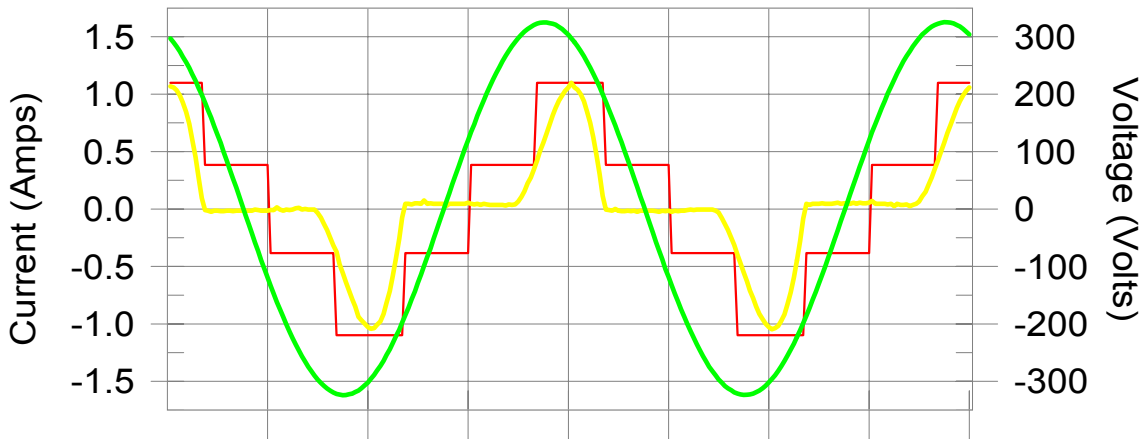

Harmonics and Class D limit line

European Limits

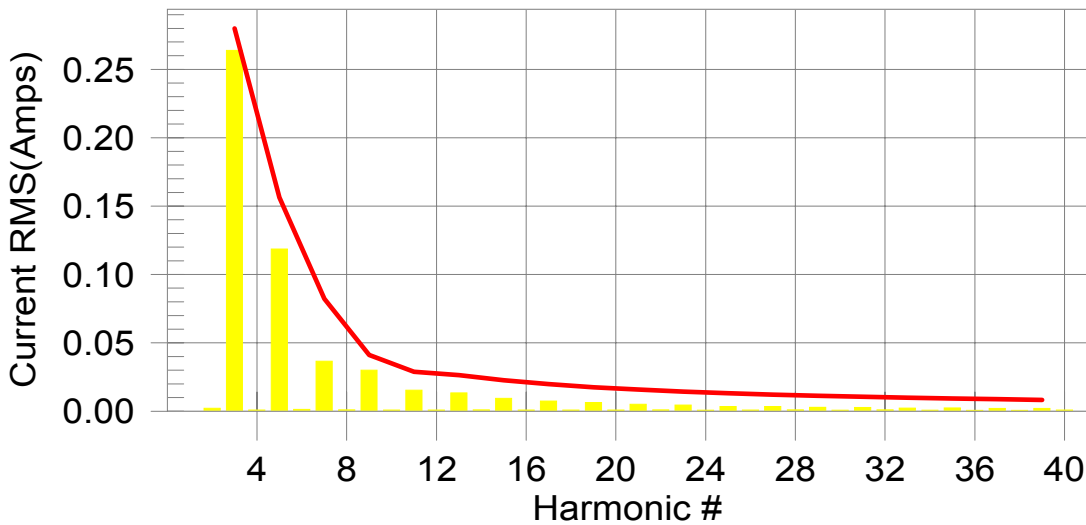

Test result: Pass

Worst harmonic was #3 with 94.27 % of the limit.

Test Result: Pass

Source qualification: Normal

Highest parameter values during test:

V_RMS (Volts):	229.64	I_RMS (Amps):	0.471
I_Peak (Amps):	1.098	Crest Factor:	2.335
I_Fund (Amps):	0.370	Power Factor:	0.763
Power (Watts):	82		

Harm#	Harmonics	Limit	% of Limit	Status
2	0.002			
3	0.264	0.280	94.24	Pass
4	0.001			
5	0.119	0.156	75.94	Pass
6	0.001			
7	0.037	0.082	44.47	Pass
8	0.001			
9	0.030	0.041	72.96	Pass
10	0.001			
11	0.015	0.029	53.36	Pass
12	0.001			
13	0.013	0.026	50.81	Pass
14	0.001			
15	0.009	0.023	41.57	Pass
16	0.001			
17	0.007	0.020	37.64	Pass
18	0.001			
19	0.006	0.018	36.38	Pass
20	0.001			
21	0.005	0.016	31.89	Pass
22	0.001			
23	0.005	0.014	0.00	Pass
24	0.001			
25	0.003	0.013	0.00	Pass
26	0.001			
27	0.004	0.012	0.00	Pass
28	0.001			
29	0.003	0.011	0.00	Pass
30	0.001			
31	0.003	0.011	0.00	Pass
32	0.001			
33	0.002	0.010	0.00	Pass
34	0.001			
35	0.002	0.009	0.00	Pass
36	0.001			
37	0.002	0.009	0.00	Pass
38	0.001			
39	0.002	0.008	0.00	Pass
40	0.001			

Note: Dynamic limits were applied for this test. The highest harmonics values in the above table may not occur at the same window as the maximum harmonics/limit ratio.

Date of Test	Jul. 16, 2002	Test Room	No.3 Shielded Room
Test Mode	Mode 2: 1600*1200/85Hz (D-SUB+S-Video)	Product	VGA Card
Test Condition	Voltage Fluctuations and Flicker		

Test Result: Pass

Status: Test Completed

Pst_i and limit line

European Limits

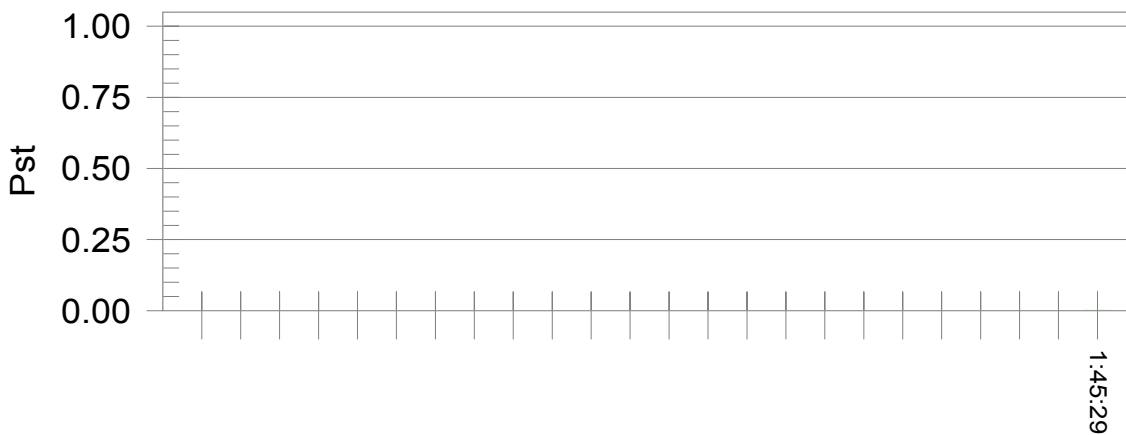

Time is too short for Plt plot

Parameter values recorded during the test:

Vrms at the end of test (Volt):	229.52		
Highest dt (%):	0.00	Test limit (%):	4.00
Highest dc (%):	0.00	Test limit (%):	3.30
Highest dmax (%):	0.00	Test limit (%):	4.00
Highest Pst (10 min. period):	0.001	Test limit:	1.000
Highest Plt (2 hr. period):	0.001	Test limit:	0.650

Date of Test	Jul. 16, 2002	Test Room	No.3 Shielded Room
Test Mode	Mode 3: 1024*768/60Hz (DVI+AV)	Product	VGA Card
Test Condition	Power Harmonics (Classification : Class D)		

Test Result: Pass

Source qualification: Normal

Current & voltage waveforms

It is 0.0% outside Class-D envelope

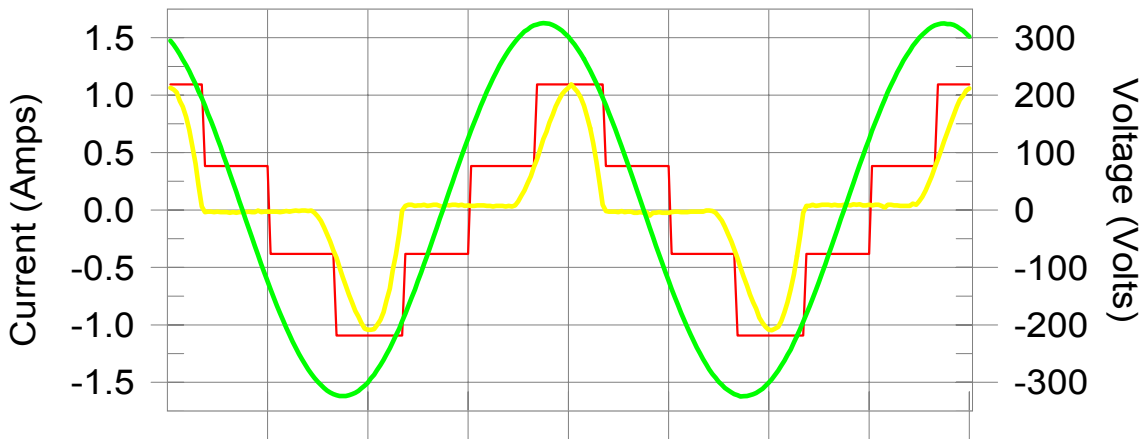

Harmonics and Class D limit line

European Limits

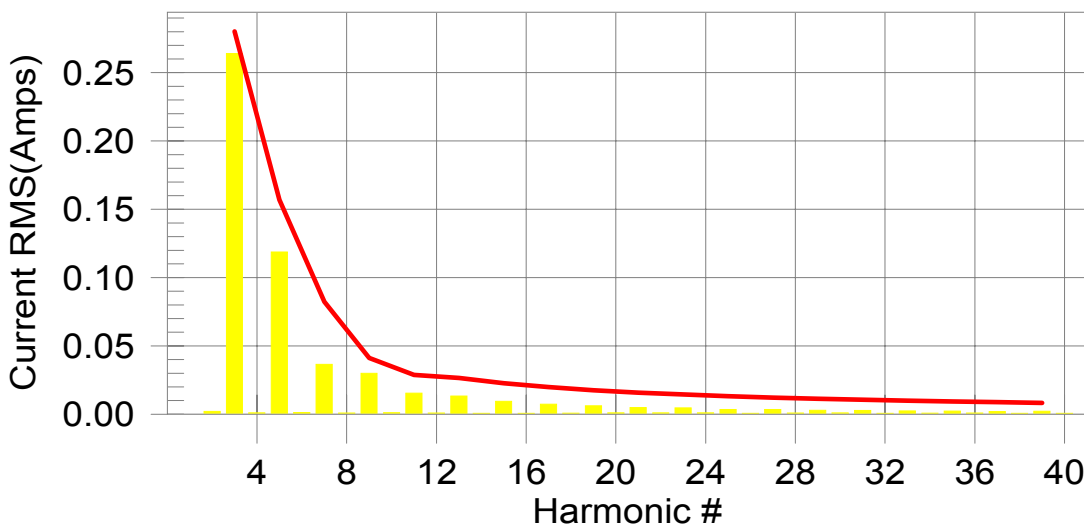

Test result: Pass

Worst harmonic was #3 with 94.30 % of the limit.

Test Result: Pass

Source qualification: Normal

Highest parameter values during test:

V_RMS (Volts):	229.69	I_RMS (Amps):	0.472
I_Peak (Amps):	1.093	Crest Factor:	2.323
I_Fund (Amps):	0.371	Power Factor:	0.763
Power (Watts):	83		

Harm#	Harmonics	Limit	% of Limit	Status
2	0.002			
3	0.264	0.280	94.18	Pass
4	0.001			
5	0.119	0.157	75.74	Pass
6	0.001			
7	0.037	0.082	44.39	Pass
8	0.001			
9	0.030	0.041	72.89	Pass
10	0.001			
11	0.015	0.029	53.48	Pass
12	0.001			
13	0.013	0.026	50.30	Pass
14	0.001			
15	0.010	0.023	41.99	Pass
16	0.001			
17	0.007	0.020	37.20	Pass
18	0.001			
19	0.006	0.018	34.96	Pass
20	0.001			
21	0.005	0.016	0.00	Pass
22	0.001			
23	0.005	0.014	0.00	Pass
24	0.001			
25	0.003	0.013	0.00	Pass
26	0.001			
27	0.004	0.012	0.00	Pass
28	0.001			
29	0.003	0.011	0.00	Pass
30	0.001			
31	0.003	0.011	0.00	Pass
32	0.001			
33	0.002	0.010	0.00	Pass
34	0.001			
35	0.002	0.009	0.00	Pass
36	0.001			
37	0.002	0.009	0.00	Pass
38	0.001			
39	0.002	0.008	0.00	Pass
40	0.001			

Note: Dynamic limits were applied for this test. The highest harmonics values in the above table may not occur at the same window as the maximum harmonics/limit ratio.

Date of Test	Jul. 16, 2002	Test Room	No.3 Shielded Room
Test Mode	Mode 1: 1920*1440/75Hz (D-SUB+DVI)	Product	VGA Card
Test Condition	Voltage Fluctuations and Flicker		

Test Result: Pass

Status: Test Completed

Pst_i and limit line

European Limits

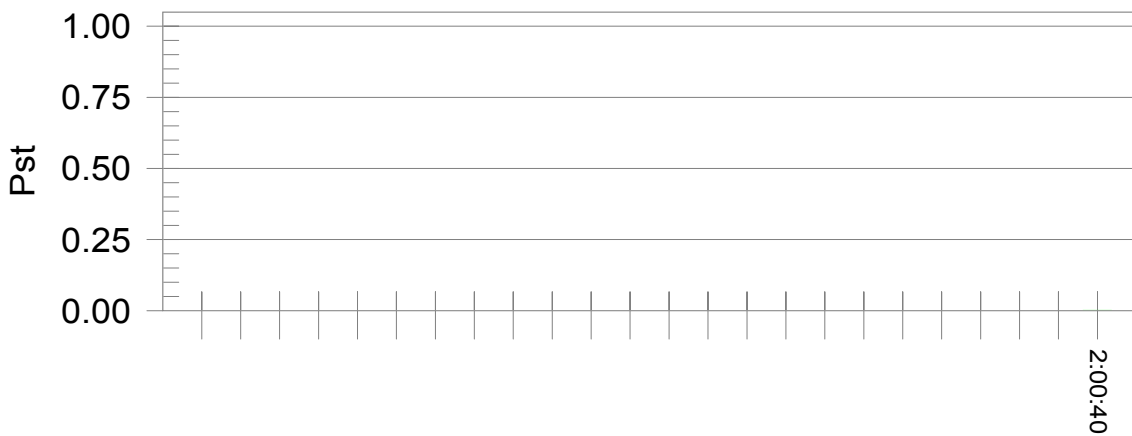

Time is too short for Plt plot

Parameter values recorded during the test:

Vrms at the end of test (Volt):	229.77		
Highest dt (%):	0.00	Test limit (%):	4.00
Highest dc (%):	0.00	Test limit (%):	3.30
Highest dmax (%):	0.00	Test limit (%):	4.00
Highest Pst (10 min. period):	0.001	Test limit:	1.000
Highest Plt (2 hr. period):	0.001	Test limit:	0.650

Date of Test	Jul. 16, 2002	Test Room	No.3 Shielded Room
Test Mode	Mode 2: 1600*1200/85Hz (D-SUB+S-Video)	Product	VGA Card
Test Condition	Power Harmonics (Classification : Class D)		

Test Result: Pass

Source qualification: Normal

Current & voltage waveforms

It is 0.0% outside Class-D envelope

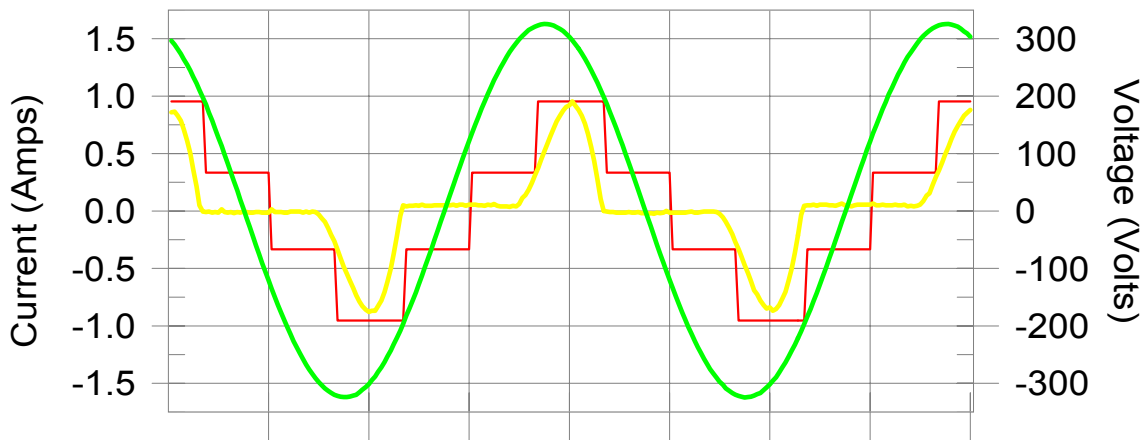

Harmonics and Class D limit line

European Limits

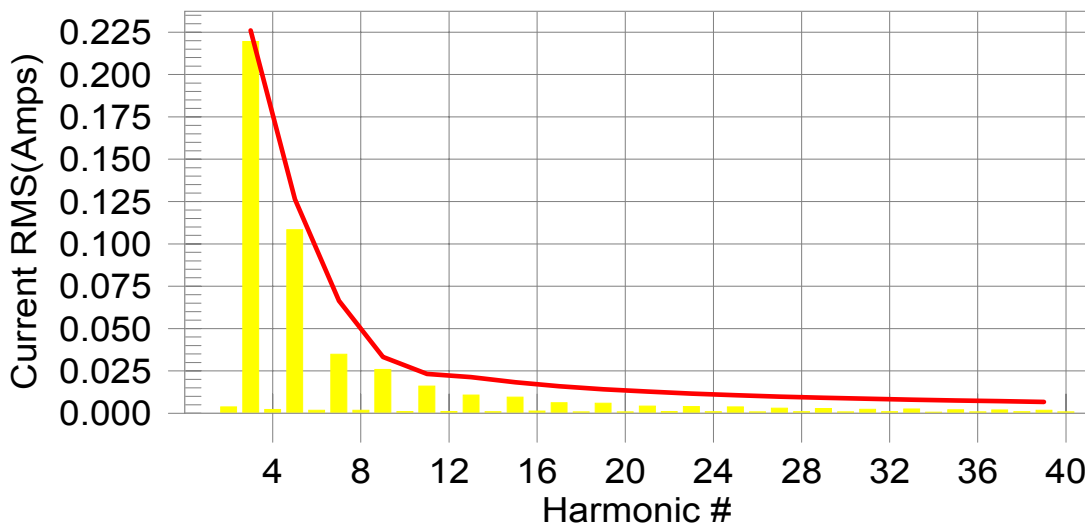

Test result: Pass

Worst harmonic was #3 with 0.00 % of the limit.

Test Result: Pass

Source qualification: Normal

Highest parameter values during test:

V_RMS (Volts):	229.79	I_RMS (Amps):	0.385
I_Peak (Amps):	0.954	Crest Factor:	2.489
I_Fund (Amps):	0.299	Power Factor:	0.755
Power (Watts):	67		

Harm#	Harmonics	Limit	% of Limit	Status
2	0.004			
3	0.220	--	--	Pass
4	0.002			
5	0.108	--	--	Pass
6	0.002			
7	0.035	--	--	Pass
8	0.002			
9	0.026	--	--	Pass
10	0.001			
11	0.016	--	--	Pass
12	0.001			
13	0.011	--	--	Pass
14	0.001			
15	0.009	--	--	Pass
16	0.001			
17	0.006	--	--	Pass
18	0.001			
19	0.006	--	--	Pass
20	0.001			
21	0.004	--	--	Pass
22	0.001			
23	0.004	--	--	Pass
24	0.001			
25	0.004	--	--	Pass
26	0.001			
27	0.003	--	--	Pass
28	0.001			
29	0.003	--	--	Pass
30	0.001			
31	0.002	--	--	Pass
32	0.001			
33	0.002	--	--	Pass
34	0.001			
35	0.002	--	--	Pass
36	0.001			
37	0.002	--	--	Pass
38	0.001			
39	0.002	--	--	Pass
40	0.001			

Note :

1.Dynamic limits were applied for this test. The highest harmonics values in the above table may not occur at the same window as the maximum harmonics/limit ratio.

2:According to EN61000-3-2 pavagraph 7.4 the limits given in table 3 are valid for all applications having an active input power >75W.

3." -- " mean the limit is not applicable

Date of Test	Jul. 16, 2002	Test Room	No.3 Shielded Room
Test Mode	Mode 3: 1024*768/60Hz (DVI+AV)	Product	VGA Card
Test Condition	Voltage Fluctuations and Flicker		

Test Result: Pass

Status: Test Completed

Pst_i and limit line

European Limits

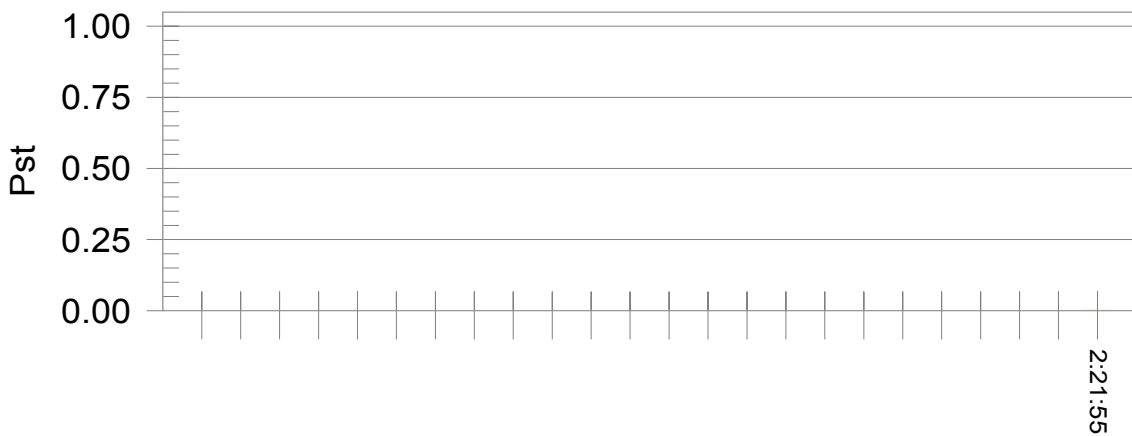

Time is too short for Plt plot

Parameter values recorded during the test:

Vrms at the end of test (Volt):	229.69		
Highest dt (%):	0.00	Test limit (%):	4.00
Highest dc (%):	0.00	Test limit (%):	3.30
Highest dmax (%):	0.00	Test limit (%):	4.00
Highest Pst (10 min. period):	0.001	Test limit:	1.000
Highest Plt (2 hr. period):	0.001	Test limit:	0.650

13.4. Test Data of Electrostatic Discharge

Date of Test	Jul. 16, 2002	Test Room	No.3 Shielded Room
Test Mode	Mode 1: 1920*1440/75Hz (D-SUB+DVI)	Product	VGA Card
Test Condition	Electrostatic Discharge (Performance Criteria: B)		

Test point	Polarity	Number of Discharges	Complied To Criteria (A,B,C)	Result
Seams	+/-8kV Air	10	A	PASS
Switch	+/-8kV Air	10	A	PASS
Knobs	+/-4kV Con	50	A	PASS
Metal Plate	+/-4kV Con	50	A	PASS
Screws	+/-4kV Con	50	A	PASS
H.C.P.	+/-4kV	50	A	PASS
V.C.P.	+/-4kV	50	A	PASS

Criteria judgment of Test result:

- Meet criteria A: No abnormalities were observed during and directly after the test.
- Meet criteria B: Operate as intended after the test
- Meet criteria C: Loss/Error of function
- Additional Information
 - EUT stopped operation and could / could not be reset by operator at ____ kV.
 - No false alarms or other malfunctions were observed during or after the test.

13.5. Test Data of Radiated Susceptibility

Date of Test	Jul. 16, 2002	Test Room	No.3 Shielded Room
Test Mode	Mode 1: 1920*1440/75Hz (D-SUB+DVI)	Product	VGA Card
Test Condition	Radiated Susceptibility (Performance Criteria: A)		

Frequency (MHz)	Position (Angle)	Polarity (H or V)	Field Strength (V/m)	Complied To Criteria (A,B,C)	Results
80-1000	0	H	3	A	Pass
80-1000	0	V	3	A	Pass
80-1000	90	H	3	A	Pass
80-1000	90	V	3	A	Pass
80-1000	180	H	3	A	Pass
80-1000	180	V	3	A	Pass
80-1000	270	H	3	A	Pass
80-1000	270	V	3	A	Pass

Criteria judgment of Test result:

- Meet criteria A: No abnormalities were observed during and directly after the test.
- Meet criteria B: Operate as intended after the test
- Meet criteria C: Loss/Error of function
- Additional Information
 - EUT stopped operation and could / could not be reset by operator at ____ kV.
 - No false alarms or other malfunctions were observed during or after the test.

13.6. Test Data of Electrical Fast Transient

Date of Test	Jul. 16, 2002	Test Room	No.3 Shielded Room
Test Mode	Mode 1: 1920*1440/75Hz (D-SUB+DVI)	Product	VGA Card
Test Condition	Electrical Fast Transient (Performance Criteria: B)		

Inject Line	Polarity	Voltage kV	Inject Time (Second)	Inject Method	Complied To Criteria (A,B,C)	Result
L	±	1kV	60	Direct	A	Pass
N	±	1kV	60	Direct	A	Pass
PE	±	1kV	60	Direct	A	Pass
L+N	±	1kV	60	Direct	A	Pass
L+PE	±	1kV	60	Direct	A	Pass
N+PE	±	1kV	60	Direct	A	Pass
L+N+PE	±	1kV	60	Direct	A	Pass

Criteria judgment of Test result:

- Meet criteria A: No abnormalities were observed during and directly after the test.
- Meet criteria B: Operate as intended after the test
- Meet criteria C: Loss/Error of function
- Additional Information
 - EUT stopped operation and could / could not be reset by operator at ____ kV.
 - No false alarms or other malfunctions were observed during or after the test.

13.7. Test Data of Surge

Date of Test	Jul. 16, 2002	Test Room	No.3 Shielded Room
Test Mode	Mode 1: 1920*1440/75Hz (D-SUB+DVI)	Product	VGA Card
Test Condition	Surge (Performance Criteria: B)		

Inject Line	Polarity	Angle	Voltage kV	Time Interval (Second)	Inject Method	Complied To Criteria (A,B,C)	Result
L-N	±	0	1kV	60	Direct	A	Pass
L-N	±	90	1kV	60	Direct	A	Pass
L-N	±	180	1kV	60	Direct	A	Pass
L-N	±	270	1kV	60	Direct	A	Pass
L-PE	±	0	2kV	60	Direct	A	Pass
L-PE	±	90	2kV	60	Direct	A	Pass
L-PE	±	180	2kV	60	Direct	A	Pass
L-PE	±	270	2kV	60	Direct	A	Pass
N-PE	±	0	2kV	60	Direct	A	Pass
N-PE	±	90	2kV	60	Direct	A	Pass
N-PE	±	180	2kV	60	Direct	A	Pass
N-PE	±	270	2kV	60	Direct	A	Pass

Criteria judgment of Test result:

- Meet criteria A: No abnormalities were observed during and directly after the test.
- Meet criteria B: Operate as intended after the test
- Meet criteria C: Loss/Error of function
- Additional Information
 - EUT stopped operation and could / could not be reset by operator at ____ kV.
 - No false alarms or other malfunctions were observed during or after the test.

13.8. Test Data of Conducted Susceptibility

Date of Test	Jul. 16, 2002	Test Room	No.3 Shielded Room
Test Mode	Mode 1: 1920*1440/75Hz (D-SUB+DVI)	Product	VGA Card
Test Condition	Conducted Susceptibility (Performance Criteria: A)		

Frequency Range (MHz)	Voltage Applied dBuV(V)	Inject Method	Tested Port of EUT	Complied To Criteria (A,B,C)	Result
0.15 ~ 80	130(3V)	CDN 1	AC IN	A	PASS

Criteria judgment of Test result:

- Meet criteria A: No abnormalities were observed during and directly after the test.
- Meet criteria B: Operate as intended after the test
- Meet criteria C: Loss/Error of function
- Additional Information
 - EUT stopped operation and could / could not be reset by operator at ____ kV.
 - No false alarms or other malfunctions were observed during or after the test.

13.9. Test Data of Power Frequency Magnetic Field

Date of Test	Jul. 16, 2002	Test Room	No.3 Shielded Room
Test Mode	Mode 1: 1920*1440/75Hz (D-SUB+DVI)	Product	VGA Card
Test Condition	Power Frequency Magnetic Field (Performance criteria: A)		

Polarization	Frequency (Hz)	Magnetic Strength (A/m)	Observation	Test Result
X Orientation	50	1	A	PASS
Y Orientation	50	1	A	PASS
Z Orientation	50	1	A	PASS

Criteria judgment of Test result:

- Meet criteria A: No abnormalities were observed during and directly after the test.
- Meet criteria B: Operate as intended after the test
- Meet criteria C: Loss/Error of function
- Additional Information
 - EUT stopped operation and could / could not be reset by operator at ____ kV.
 - No false alarms or other malfunctions were observed during or after the test.

13.10. Test Data of Voltage Dips and Interruption

Date of Test	Jul. 16, 2002	Test Room	No.3 Shielded Room
Test Mode	Mode 1: 1920*1440/75Hz (D-SUB+DVI)	Product	VGA Card
Test Condition	Voltage Dips and Interruption		

Voltage Dips and Interruption Reduction(%)	Angle	Test Duration (Periods)	Required Performance Criteria	Observation	Test Result
>95(0V)	0	0.5	B	A	PASS
>95(0V)	45	0.5	B	A	PASS
>95(0V)	90	0.5	B	A	PASS
>95(0V)	135	0.5	B	A	PASS
>95(0V)	180	0.5	B	A	PASS
>95(0V)	225	0.5	B	A	PASS
>95(0V)	270	0.5	B	A	PASS
>95(0V)	315	0.5	B	A	PASS
30(161V)	0	25	C	A	PASS
30(161V)	45	25	C	A	PASS
30(161V)	90	25	C	A	PASS
30(161V)	135	25	C	A	PASS
30(161V)	180	25	C	A	PASS
30(161V)	225	25	C	A	PASS
30(161V)	270	25	C	A	PASS
30(161V)	315	25	C	A	PASS
>95(0V)	0	250	C	C	PASS
>95(0V)	45	250	C	C	PASS
>95(0V)	90	250	C	C	PASS
>95(0V)	135	250	C	C	PASS
>95(0V)	180	250	C	C	PASS
>95(0V)	225	250	C	C	PASS
>95(0V)	270	250	C	C	PASS
>95(0V)	315	250	C	C	PASS

Criteria judgment of Test result:

- Meet criteria A: No abnormalities were observed during and directly after the test.
- Meet criteria B: Operate as intended after the test
- Meet criteria C: Loss/Error of function
- Additional Information
 - EUT stopped operation and could be reset by operator.
 - No false alarms or other malfunctions were observed during or after the test.

Attachment 1 : EUT Test Photographs

Attachment 1: EUT Test Setup Photographs

Front View of Conducted Test (Mode 1)



Back View of Conducted Test (Mode 1)



Front View of Radiated Test (Mode 1)



Back View of Radiated Test (Mode 1)

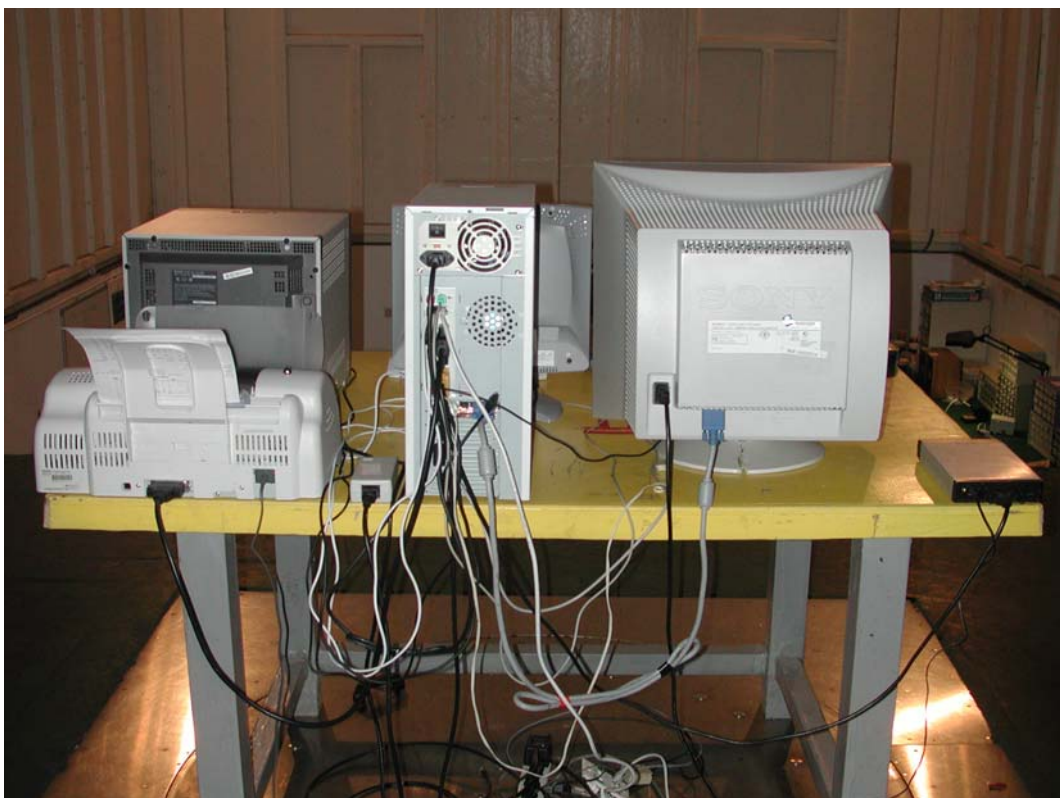

Front View of Conducted Test (Mode 2)



Back View of Conducted Test (Mode 2)



Front View of Radiated Test (Mode 2)



Back View of Radiated Test (Mode 2)



Front View of Conducted Test (Mode 3)



Back View of Conducted Test (Mode 3)



Front View of Radiated Test (Mode 3)



Back View of Radiated Test (Mode 3)

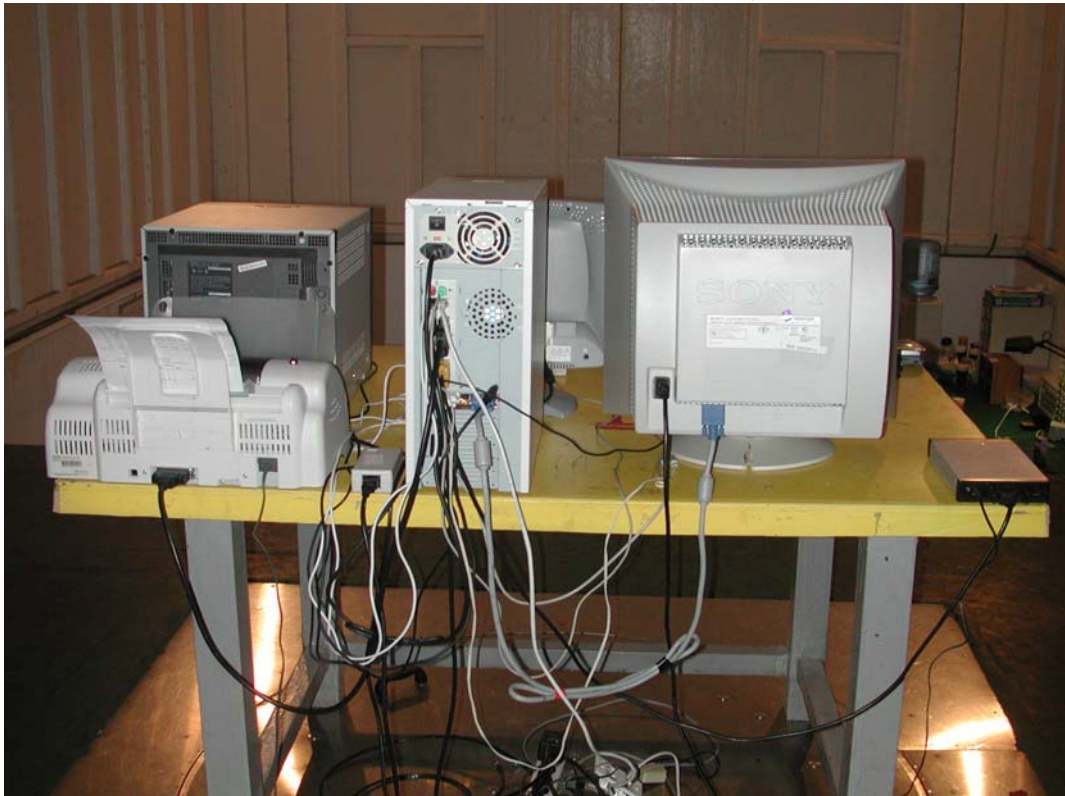

Power Harmonics Test Setup



ESD Test Setup



Radiated Susceptibility Test Setup



EFT/B Test Setup



SURGE Test Setup



Conducted Susceptibility Test Setup



Power Frequency Magnetic Field Test Setup



Voltage Dips Test Setup



Attachment 2 : EUT Detailed Photographs

Attachment 2 : EUT Detailed Photographs

(1) EUT Photo

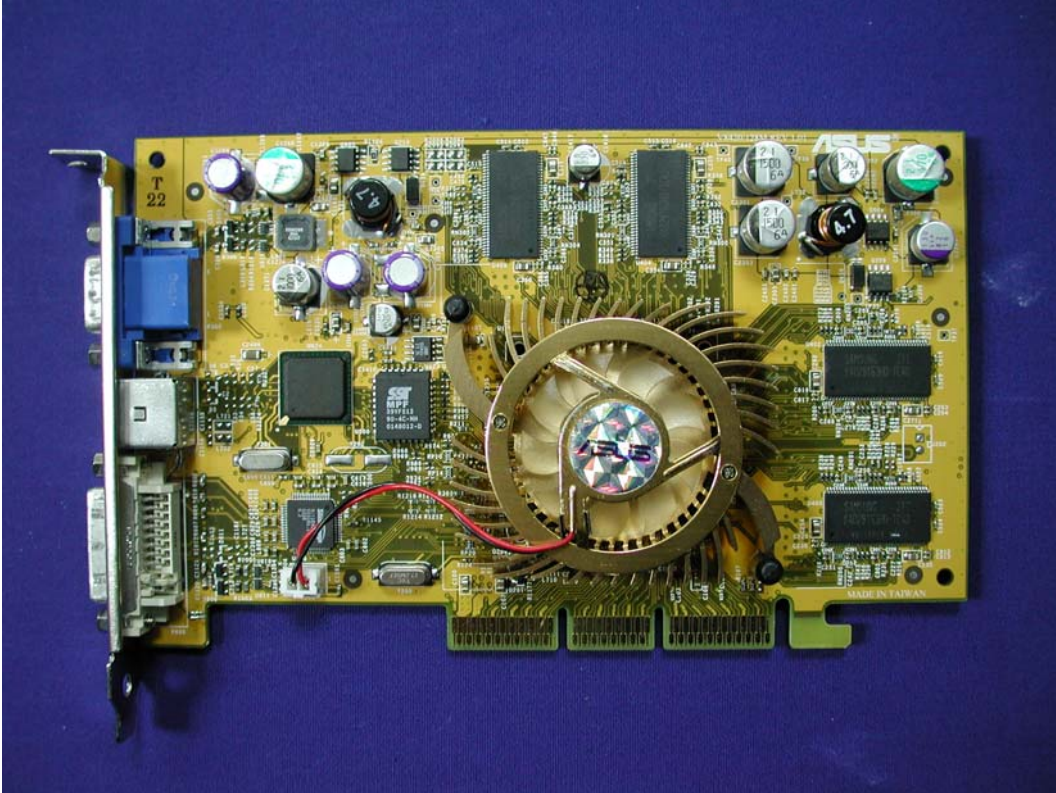

(2) EUT Photo

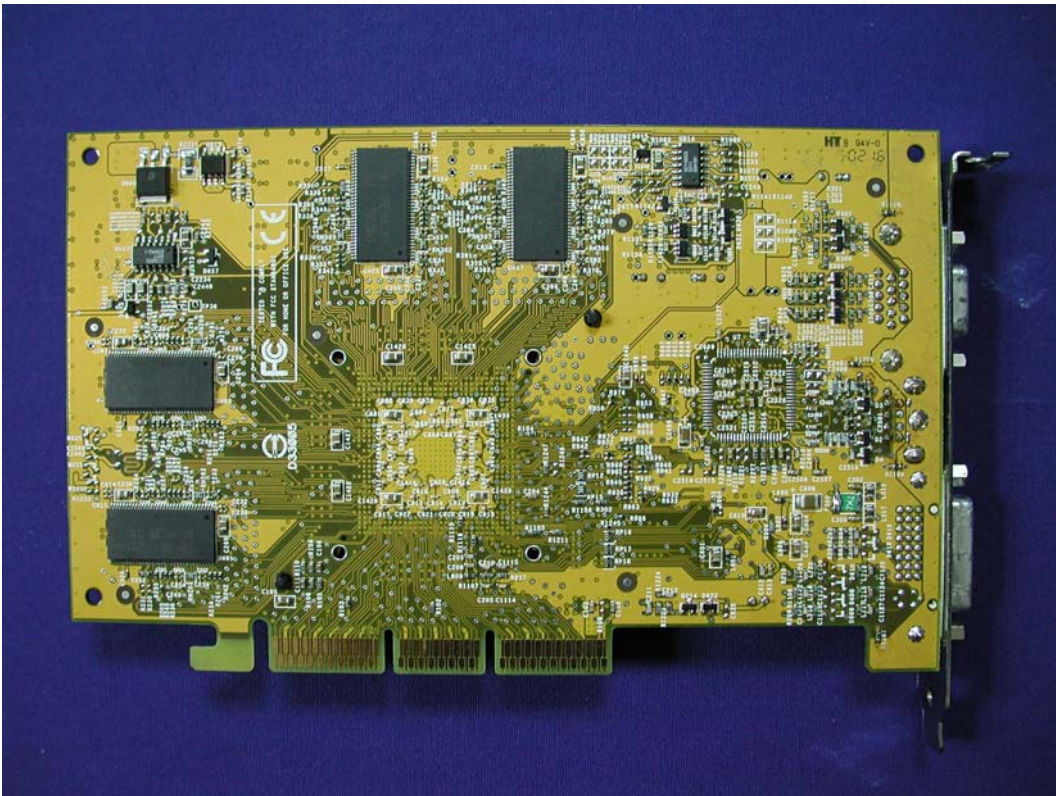

(3) EUT Photo



(4) EUT Photo

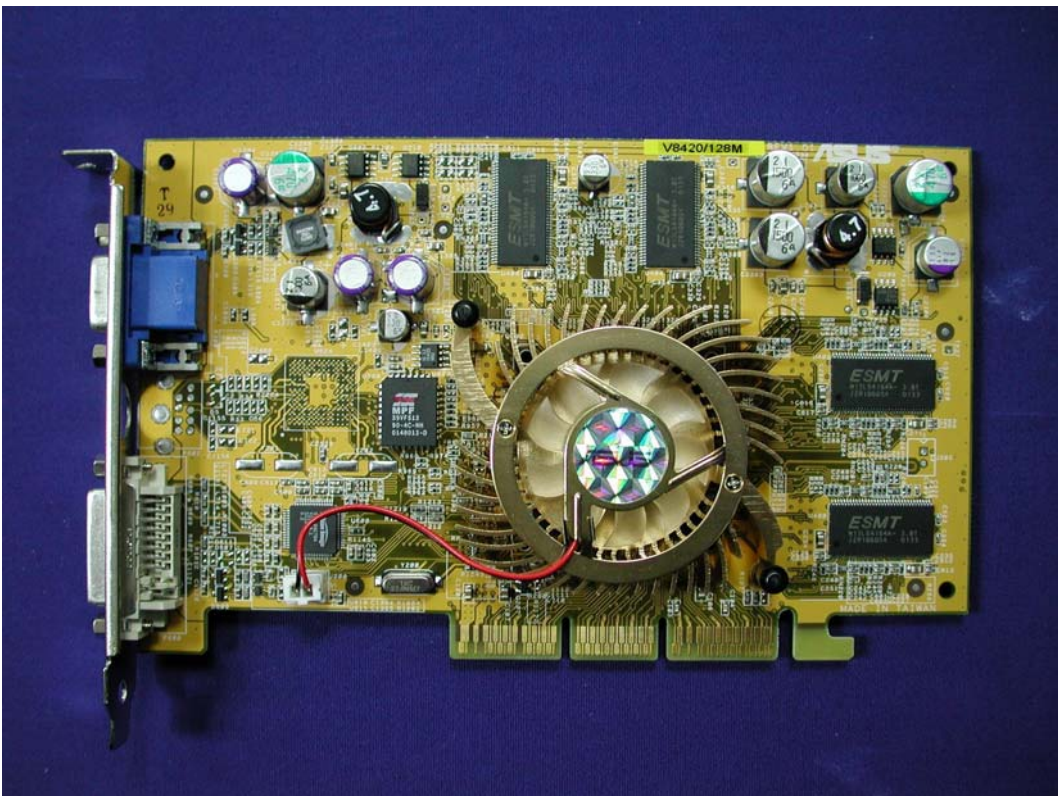

(5) EUT Photo

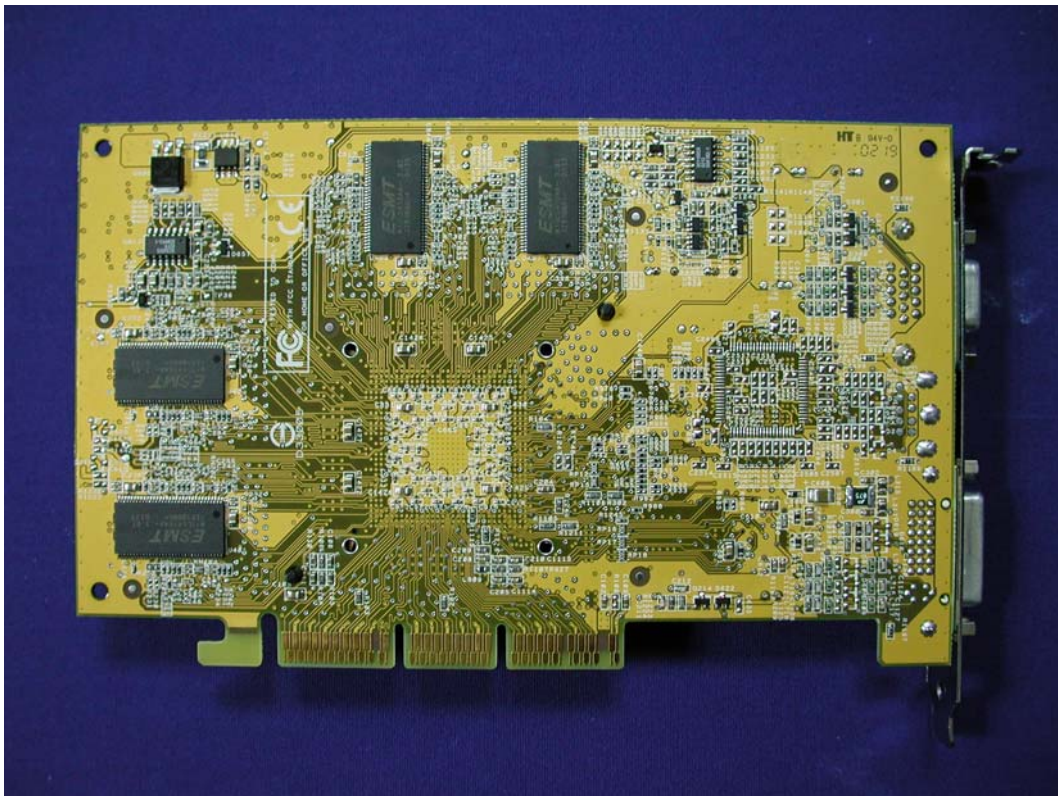

(6) EUT Photo

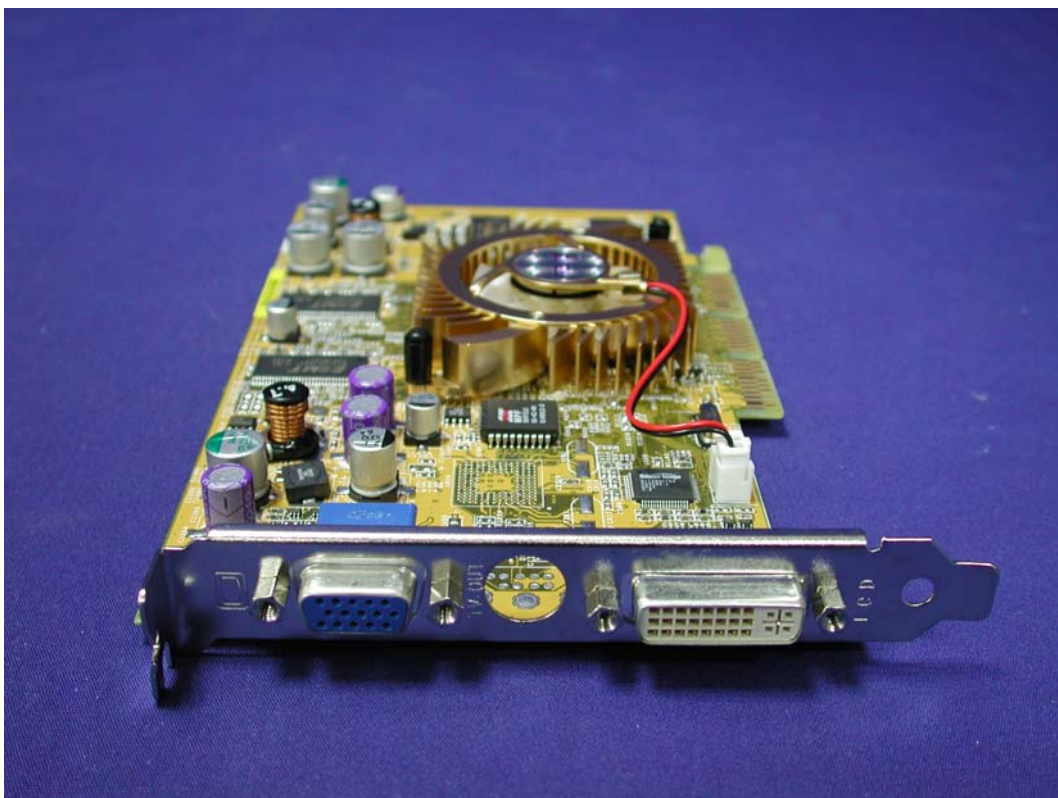

(7) EUT Photo

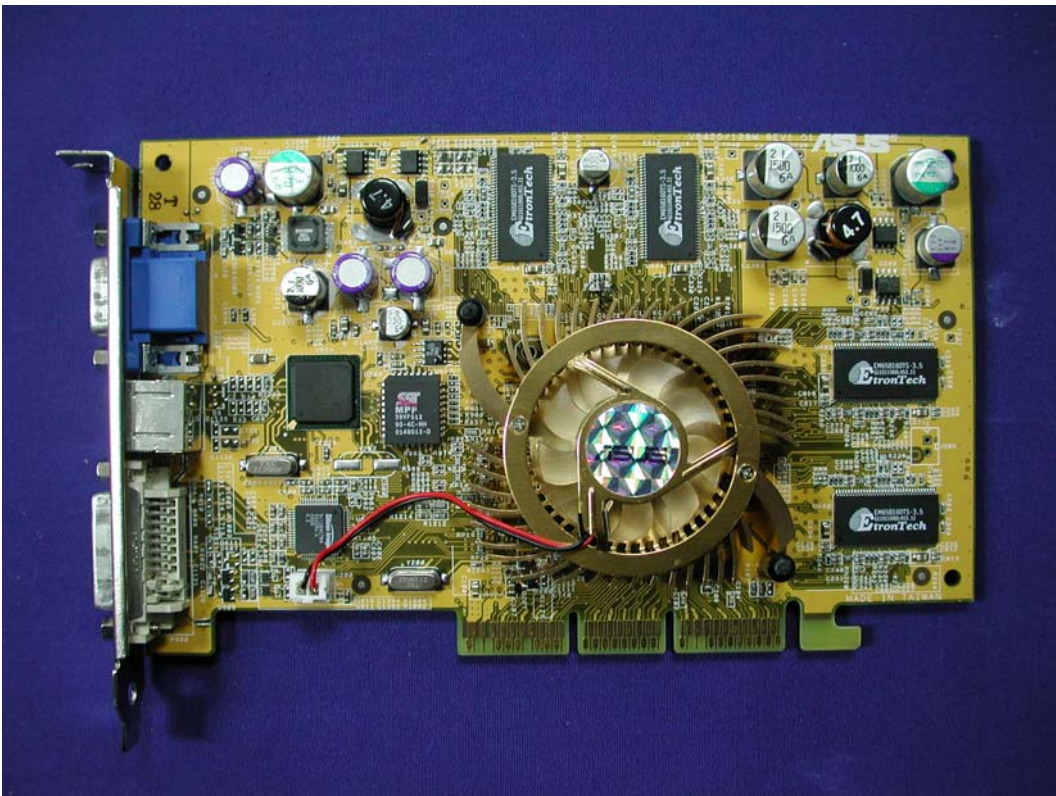

(8) EUT Photo

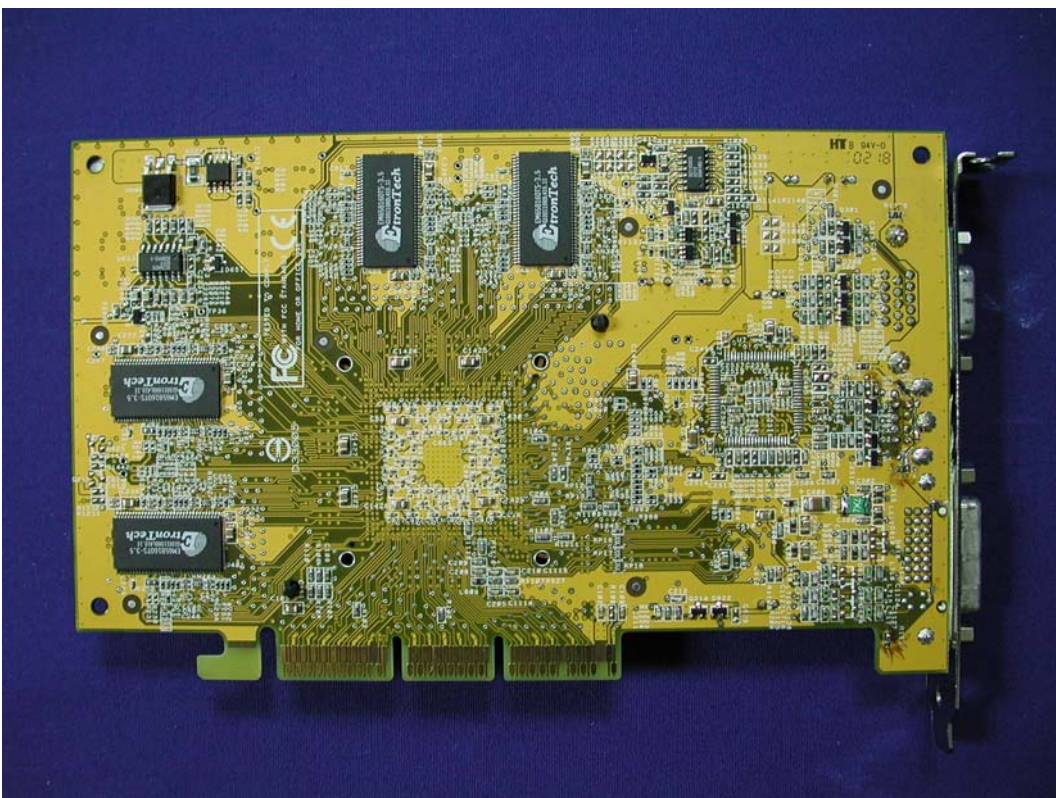

(9) EUT Photo



(10) EUT Photo

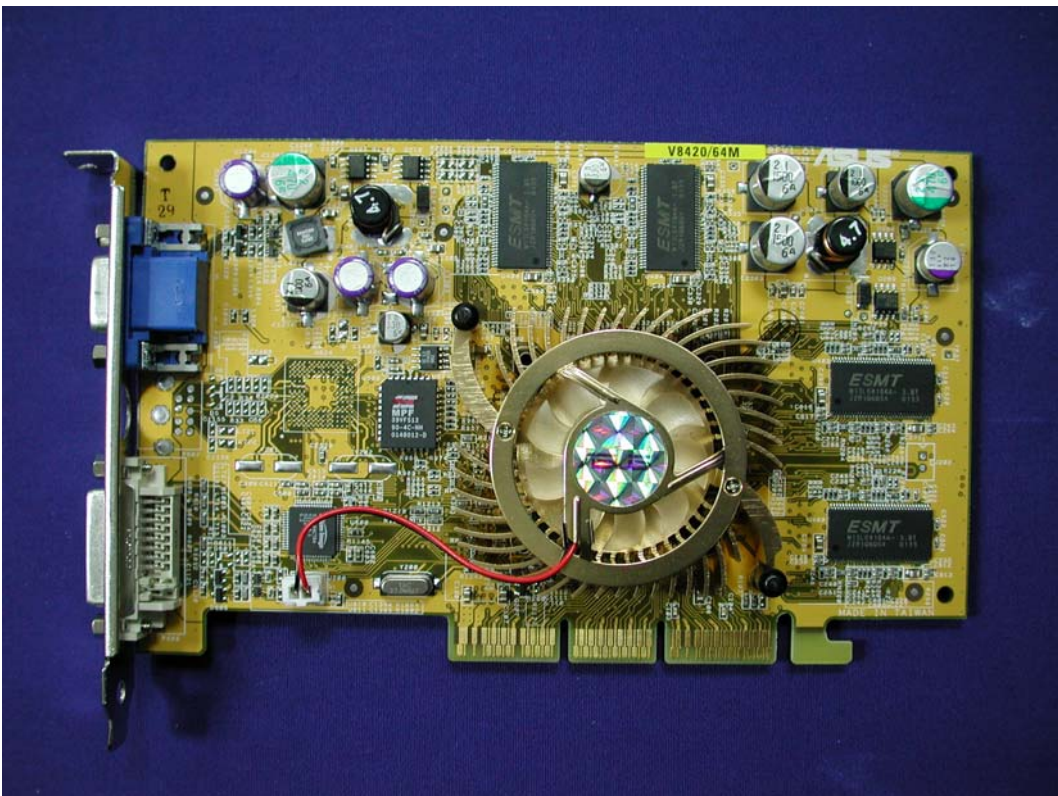

(11) EUT Photo

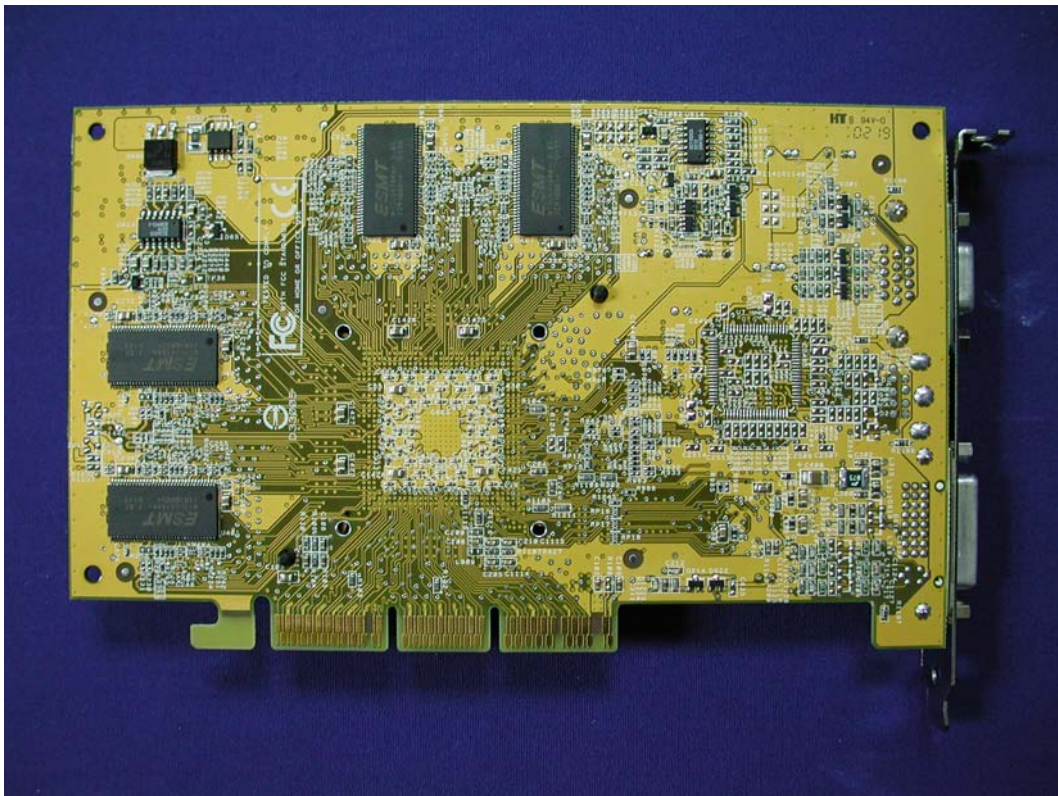

(12) EUT Photo

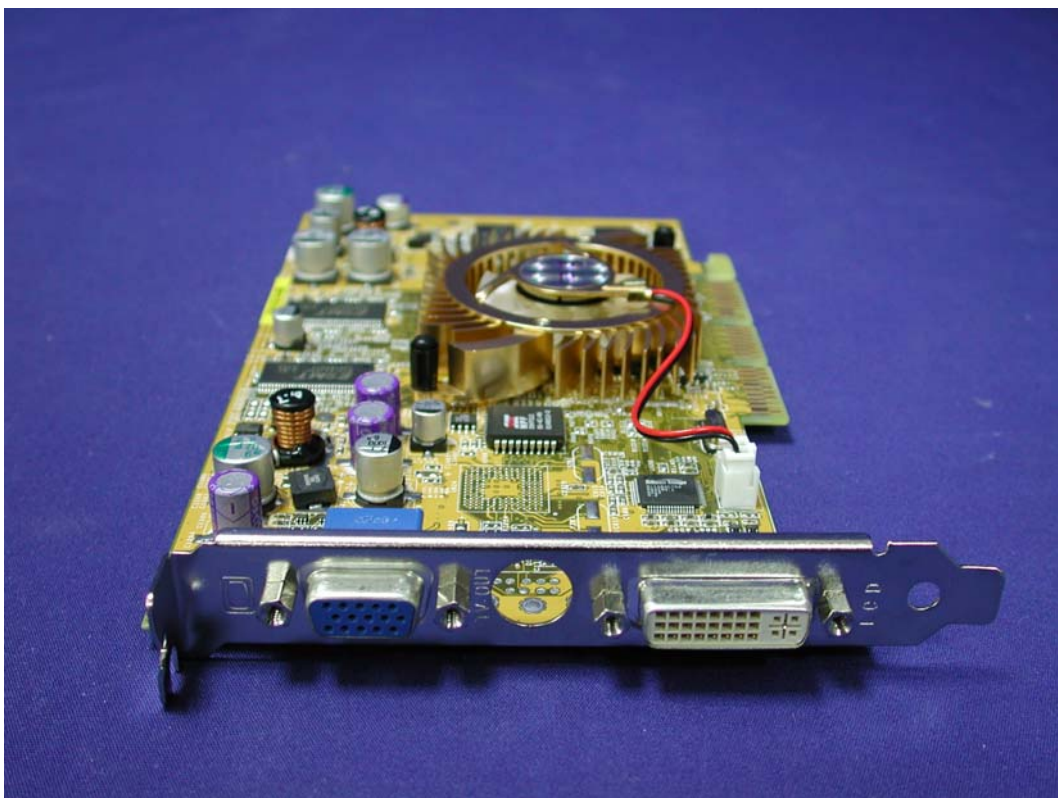

Reference : Laboratory of License

Scope of Accreditation



ELECTROMAGNETIC COMPATIBILITY AND TELECOMMUNICATIONS

NVLAP LAB CODE 200533-0

QUITEK CORPORATION

No. 5, Ruei-shu Valley, Ruei-ping, Tsuen
Lin Kou Shiang, Taipei 244
TAIWAN

Mr. Gene Chang

Phone: 886-2-8601-3788 Fax: 886-2-8601-3789

E-Mail: gene@quietek.com

NVLAP Code Designation / Description

Emissions Test Methods:

12/CIS22	IEC/CISPR 22 (1997) and EN 55022 (1998): Limits and methods of measurement of radio disturbance characteristics of information technology equipment
12/CIS22a	IEC/CISPR 22:1993: Limits and methods of measurement of radio disturbance characteristics of information technology equipment, Amendment 1:1995, and Amendment 2:1996.
12/CIS22b	CNS 13438:1997: Limits and Methods of Measurement of Radio Interference Characteristics of Information Technology Equipment
12/F01	FCC Method - 47 CFR Part 15 - Digital Devices
12/F01a	Conducted Emissions, Power Lines, 450 KHz to 30 MHz
12/F01b	Radiated Emissions

June 30, 2003

Effective through

For the National Institute of Standards and Technology

Scope of Accreditation



ELECTROMAGNETIC COMPATIBILITY AND TELECOMMUNICATIONS

NVLAP LAB CODE 200533-0

QUITEK CORPORATION

NVLAP Code *Designation / Description*

12/T51 AS/NZS 3548: Electromagnetic Interference - Limits and Methods of Measurement
of Information Technology Equipment

Immunity Test Methods:

- 12/I01 IEC 61000-4-2 (1995) and Amendment 1 (1998): Electrostatic Discharge Immunity
Test
- 12/I02 IEC 61000-4-3 (1995) and Amendment 1 (1998): Radiated, Radio-Frequency
Electromagnetic Field Immunity Test
- 12/I03 IEC 61000-4-4 (1995): Electrical Fast Transient/Burst Immunity Test
- 12/I04 IEC 61000-4-5 (1995): Surge Immunity Test
- 12/I05 IEC 61000-4-6 (1996): Immunity to Conducted Disturbances, Induced
Radio-Frequency Fields
- 12/I06 IEC 61000-4-8 (1993): Power Frequency Magnetic Field Immunity Test
- 12/I07 IEC 61000-4-11 (1994): Voltage Dips, Short Interruptions and Voltage Variations
Immunity Tests

June 30, 2003

Effective through

David F. Alderman

For the National Institute of Standards and Technology

United States Department of Commerce
National Institute of Standards and Technology

NVLAP[®]

ISO/IEC GUIDE 25:1990
ISO 9002:1987

Certificate of Accreditation



QUITEK CORPORATION

LIN KOU SHIANG, TAIPEI 244
TAIWAN

is recognized under the National Voluntary Laboratory Accreditation Program for satisfactory compliance with criteria established in Title 15, Part 285 Code of Federal Regulations. These criteria encompass the requirements of ISO/IEC Guide 25 and the relevant requirements of ISO 9002 (ANSI/ASQC Q92-1987) as suppliers of calibration or test results. Accreditation is awarded for specific services, listed on the Scope of Accreditation for:

ELECTROMAGNETIC COMPATIBILITY AND TELECOMMUNICATIONS

June 30, 2003

Effective through

David F. Alderman

For the National Institute of Standards and Technology

NVLAP Lab Code: 200533-0

EMC Laboratory Authorisation

Aut. No. : ELA 165

EMC Laboratory:

**Quietek Corporation
No. 75-2, Wang-Yeh Valley,
Yung-Hsing, Chiung-Lin, Hsin-Chu,
Hsin-Chu County, Taiwan R.O.C.**

Scope of Authorization: All CENELEC standards [ENs] for EMC that are listed on the accompanying page, and, all of the corresponding CISPR, IEC, and ISO EMC standards that are listed on the accompanying page.

This Authorisation Document confirms that the above mentioned EMC Laboratory has been validated against EN 45001 and found to be compliant. The laboratory also fulfils the conditions described in Nemko Document ELA 10. During Nemko's visit to the laboratory, an assessment was made of the relevant parts of your organisation - i.e. facilities, personnel qualifications, test equipment, and testing practices. It was found that the EMC Laboratory is capable of performing tests within the Scope of Authorisation given on the accompanying page. Accordingly, Nemko will accept your test reports as a basis for attesting conformity to these EMC Standards for the products in question under the European Union EMC Directive [89/336/EEC as amended by 92/31/EEC and 98/13/EC].

In case of applications for Product Certification(s) to be issued by Nemko, your EMC Laboratory's test report(s) will be accepted by Nemko if they are enclosed with the Application Form submitted by the manufacturer.

In order to maintain this Authorization, the information given in the enclosed ELA-INFOs (if any) must be carefully followed. Nemko is to be promptly notified about any changes in the situation at your EMC Laboratory which may affect the basis for this Authorization. The Authorization may at any time be withdrawn if the conditions are no longer considered to be fulfilled.

The Authorisation is valid through **31. December 2003**.

Oslo, 18. April 2001

For Nemko AS:

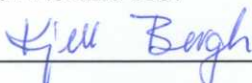

Kjell Bergh, Nemko Group EMC Co-ordinator

EMC Laboratory Authorisation

Aut. No. : ELA 162

EMC Laboratory:

**Quietek Corporation
No. 75-2, Wang-Yeh Valley,
Yung-Hsing, Chiung-Lin, Hsin-Chu,
Hsin-Chu County, Taiwan R.O.C.**

Scope of Authorization:

**EN 60601-1-2 and IEC 60601-1-2, the Collateral Standards
for electromedical products, with particular application to
EMC requirements only.**

This Authorisation Document confirms that the above mentioned EMC Laboratory has been validated against EN 45001 and found to be compliant. The laboratory also fulfils the conditions described in Nemko Document ELA 10. During Nemko's visit to the laboratory, an assessment was made of the relevant parts of your organisation - i.e. facilities, personnel qualifications, test equipment, and testing practices. It was found that the EMC Laboratory is capable of performing tests within the Scope of Authorisation listed above. Accordingly, Nemko will accept your test reports as a basis for attesting conformity to these EMC Standards for the products in question under either the European Union Medical Device Directive [MDD], 93/42/EEC, or the European Union Active Implantable Medical Device Directive [AIMD], 90/385/EEC, (as applicable).

In case of applications for Product Certification(s) to be issued by Nemko, your EMC Laboratory's test report(s) will be accepted by Nemko if they are enclosed with the Application Form submitted by the manufacturer.

In order to maintain the Authorisation, the information given in the enclosed ELA-INFOs (if any) must be carefully followed. Nemko is to be promptly notified about any changes in the situation at your EMC Laboratory which may affect the basis for this Authorisation. The Authorisation may at any time be withdrawn if the conditions are no longer considered to be fulfilled.

The Authorisation is valid through **31. December 2001**.

Oslo, 18. April 2001

For Nemko AS:

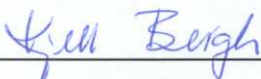

Kjell Bergh, Nemko Group EMC Co-ordinator

EMC Laboratory Authorisation

Aut. No. : ELA 191

(Page 2 of 2)

SCOPE OF AUTHORISATION

Generic and product-family standards – R&TTE Directive

EN 300 220-3 :2000	ETS 300 328:1996 + A1:97 EN 300 328-2:2000	I-ETS 300 330:1994 + A1:97 (Not harmonised for R&TTE-D)
EN 300 422-2 :2000	I-ETS 300 440:1995 (Not harmonised for R&TTE-D)	ETS 300 445 :1996 + A1 :97 EN 301 489-09 :2000
ETS 300 683 :1997 EN 301 489-03 :2000	ETS 300 826 :1997 EN 301 489-17 :2000	EN 301 489-01:2000

Basic standards

EN 61000-4-2:1995 + A1:98 IEC 61000-4-2:1995 + A1:98 (EN 60801-1:1993 IEC 801.2:1991 IEC 801.2:1984)	EN 61000-4-3:1996 + A1:98 IEC 61000-4-3:1995 + A1:98 (IEC 801.3:1984 ENV 50140:1993 + ENV 50204:1995)	EN 61000-4-4:1995 IEC 61000-4-4:1995 (IEC 801.4:1990)
EN 61000-4-5:1995 IEC 61000-4-5:1995 (ENV 50142:1994)	EN 61000-4-6:1996 IEC 61000-4-6:1996 (ENV 50141:1993)	EN 61000-4-8:1993 IEC 61000-4-8:1993
EN 61000-4-11:1994 IEC 61000-4-11:1994		

Oslo, 24 April 2001

Kjell Bergh, Nemko Group EMC Co-ordinator

**EMC Laboratory
Authorisation****Aut. No. : ELA 162**

EMC Laboratory: **QuieTek Corporation
No. 75-2, Wang-Yeh Valley,
Yung-Hsing, Chiung-Lin, Hsin-Chu,
Hsin-Chu County, Taiwan R.O.C.**

Scope of Authorization: **EN 60601-1-2 and IEC 60601-1-2, the Collateral Standards
for electromedical products, with particular application to
EMC requirements only.**

This Authorisation Document confirms that the above mentioned EMC Laboratory has been validated against EN 45001 and found to be compliant. The laboratory also fulfils the conditions described in Nemko Document ELA 10. During Nemko's visit to the laboratory, an assessment was made of the relevant parts of your organisation - i.e. facilities, personnel qualifications, test equipment, and testing practices. It was found that the EMC Laboratory is capable of performing tests within the Scope of Authorisation listed above. Accordingly, Nemko will accept your test reports as a basis for attesting conformity to these EMC Standards for the products in question under either the European Union Medical Device Directive [MDD], 93/42/EEC, or the European Union Active Implantable Medical Device Directive [AIMD], 90/385/EEC, (as applicable).

In case of applications for Product Certification(s) to be issued by Nemko, your EMC Laboratory's test report(s) will be accepted by Nemko if they are enclosed with the Application Form submitted by the manufacturer.

In order to maintain the Authorisation, the information given in the enclosed ELA-INFOs (if any) must be carefully followed. Nemko is to be promptly notified about any changes in the situation at your EMC Laboratory which may affect the basis for this Authorisation. The Authorisation may at any time be withdrawn if the conditions are no longer considered to be fulfilled.

The Authorisation is valid through **31. December 2003.**

Oslo, 24. April 2001

For Nemko AS:

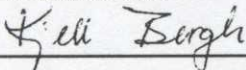

Kjell Bergh, Nemko Group EMC Co-ordinator

EMC Laboratory Authorisation
Aut. No. : ELA 165
(Page 2 of 2)
SCOPE OF AUTHORIZATION
GENERIC & PRODUCT-FAMILY STANDARDS

EN 50081-1:1992 IEC 61000-6-3 EN 50081-2:1993 IEC 61000-6-4:1997	EN 50082-1:1992 EN 50082-1 :1997 IEC 61000-6-1:1997 EN 50082-2:1995 EN 61000-6-2:1999 IEC 61000-6-2:1999	EN 50091-2:1995
EN 50130-4:1995 + A1:98	EN 55011:1991 + A1:97 + A2:96 CISPR 11:1990 + A1:96 + A2:96 EN 55011:1998 + CISPR 11:97	EN 55013:90 + A12:94 + A13:96 + A14 :99 CISPR 13:75 + A1:83
EN 55014-1:1993 + A1:97 + A2 :99 CISPR 14:1993 + A1:96 + A2 :	EN 55014-2:1997 CISPR 14-2:1997 EN 55104:1995	EN 55015:1993, CISPR 15:1992 EN 55015:1996 + A1:97 CISPR 15:96 + A1:97
EN 55022:1994 + A1:95 + A2:97 CISPR 22:1993 + A1:95 + A2:96 EN 55022:1998, CISPR 22:1997	EN 55024:1998 CISPR 24:1997	EN 55103-1:1996
EN 55103-2:1996		
EN 61000-3-2:1995 + A1:98 + A2:98 + A14 :00 IEC 61000-3-2:1995 + A1:97 + A2:98 IEC 61000-3-2 :2000	EN 61000-3-3:1995, IEC 61000-3-3:1994 EN 61000-3-11 :2000 IEC 61000-3-11 :2000	EN 61326-1:1997 + A1:98 IEC 61326:1997 + A1:98

BASIC STANDARDS

EN 61000-4-2:1995 + A1:98 IEC 61000-4-2:1995 + A1:98 (EN 60801-1:1993 IEC 801.2:1991 IEC 801.2:1984)	EN 61000-4-3:1996 + A1:98 IEC 61000-4-3:1995 + A1:98 (IEC 801.3:1984 ENV 50140:1993 + ENV 50204:1995)	EN 61000-4-4:1995 IEC 61000-4-4:1995 (IEC 801.4:1990)
EN 61000-4-5:1995 IEC 61000-4-5:1995 (ENV 50142:1994)	EN 61000-4-6:1996 IEC 61000-4-6:1996 (ENV 50141:1993)	EN 61000-4-8:1993 IEC 61000-4-8:1993
EN 61000-4-11:1994 IEC 61000-4-11:1994		

Oslo, 24 April 2001
Kjell Bergh, Nemko Group EMC Co-ordinator
Postal address:
Telephone: +47 22 96 03 30

P.O.Box 73 Blindern

Fax: +47 22 96 05 50

N-0314 OSLO, NORWAY

EMC Laboratory Authorisation**Aut. No. : ELA 191****Testing of
Radio & Telecommunications Terminal Equipment**

**EMC
Laboratory:** **QuieTek Corporation**
No. 75-2, Wang-Yeh Valley,
Yung-Hsing, Chiung-Lin, Hsin-Chu,
Hsin-Chu County, Taiwan R.O.C.

**Scope of
Authorisation:** **All CENELEC and ETSI standards [ENs and ETSs that are listed on the
accompanying page, and, all of the corresponding CISPR, IEC, and ISO EMC
standards]. This authorisation covers all of the EMC-related testing and
documentation within the scope of the *Radio and Telecommunications Terminal
Equipment [R&TTE] Directive [i.e. 1999/5/EC].***

**NOTE: This authorisation also covers EMC-related testing and documentation
that is within the scope of Article 10.5 of the *EMC Directive [i.e. 89/336/EEC as
amended by 92/31/EEC]***

This Authorisation Document confirms that the above mentioned EMC Laboratory has been validated against EN 45001 and found to be compliant. The laboratory also fulfils the conditions described in Nemko Document ELA 10. During Nemko's visit to the laboratory, an assessment was made of the relevant parts of your organisation - i.e. facilities, personnel qualifications, test equipment, and testing practices. It was found that the EMC Laboratory is capable of performing tests within the Scope of Authorisation given on the accompanying page. Accordingly, Nemko will accept your test reports as a basis for attesting conformity to these EMC Standards for the products in question under the European Union's Directives specified above

For Type Examination Certification(s) to be issued by Nemko, your EMC Laboratory's test report(s) will be accepted by Nemko if they are enclosed with the Application Form submitted by the manufacturer.

In order to maintain the Authorisation, the information given in the enclosed ELA-INFOs (if any) must be carefully followed. Nemko is to be promptly notified about any changes in the situation at your EMC Laboratory which may affect the basis for this Authorisation. The Authorisation may at any time be withdrawn if the conditions are no longer considered to be fulfilled.

The Authorisation is valid through **31. December 2003.**

Oslo, 24. April 2001

For Nemko AS:

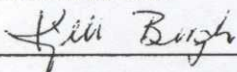

Kjell Bergh, Nemko Group EMC Co-ordinator