

ASUS[®] AP1700

Intel[®] Xeon Tower/5U Rackmount Server
with 533MHz FSB support



User's Manual

Disclaimer/Copyrights

No part of this manual, including the products and software described in it, may be reproduced, transmitted, transcribed, stored in a retrieval system, or translated into any language in any form or by any means, except documentation kept by the purchaser for backup purposes, without the express written permission of ASUSTeK COMPUTER INC. ("ASUS").

ASUS PROVIDES THIS MANUAL "AS IS" WITHOUT WARRANTY OF ANY KIND, EITHER EXPRESS OR IMPLIED, INCLUDING BUT NOT LIMITED TO THE IMPLIED WARRANTIES OR CONDITIONS OF MERCHANTABILITY OR FITNESS FOR A PARTICULAR PURPOSE. IN NO EVENT SHALL ASUS, ITS DIRECTORS, OFFICERS, EMPLOYEES OR AGENTS BE LIABLE FOR ANY INDIRECT, SPECIAL, INCIDENTAL, OR CONSEQUENTIAL DAMAGES (INCLUDING DAMAGES FOR LOSS OF PROFITS, LOSS OF BUSINESS, LOSS OF USE OR DATA, INTERRUPTION OF BUSINESS AND THE LIKE), EVEN IF ASUS HAS BEEN ADVISED OF THE POSSIBILITY OF SUCH DAMAGES ARISING FROM ANY DEFECT OR ERROR IN THIS MANUAL OR PRODUCT.

Product warranty or service will not be extended if: (1) the product is repaired, modified or altered, unless such repair, modification or alteration is authorized in writing by ASUS; or (2) the serial number of the product is defaced or missing.

Products and corporate names appearing in this manual may or may not be registered trademarks or copyrights of their respective companies, and are used only for identification or explanation and to the owners' benefit, without intent to infringe.

The product name and revision number are both printed on the product itself. Manual revisions are released for each product design represented by the digit before and after the period of the manual revision number. Manual updates are represented by the third digit in the manual revision number.

For previous or updated manuals, BIOS, drivers, or product release information, contact ASUS at <http://www.asus.com.tw> or through any of the means indicated on the following page.

SPECIFICATIONS AND INFORMATION CONTAINED IN THIS MANUAL ARE FURNISHED FOR INFORMATIONAL USE ONLY, AND ARE SUBJECT TO CHANGE AT ANY TIME WITHOUT NOTICE, AND SHOULD NOT BE CONSTRUED AS A COMMITMENT BY ASUS. ASUS ASSUMES NO RESPONSIBILITY OR LIABILITY FOR ANY ERRORS OR INACCURACIES THAT MAY APPEAR IN THIS MANUAL, INCLUDING THE PRODUCTS AND SOFTWARE DESCRIBED IN IT.

Copyright © 2003 ASUSTeK COMPUTER INC. All Rights Reserved.

Product Name:	AP1700
Manual Revision:	Revised Edition V2 E1182
Release Date:	March 2003

ASUS Contact Information

ASUSTeK COMPUTER INC. (Asia-Pacific)

Address: 150 Li-Te Road, Peitou, Taipei, Taiwan 112
General Tel: +886-2-2894-3447
General Fax: +886-2-2894-3449
General Email: info@asus.com.tw

Technical Support

MB/Others (Tel): +886-2-2890-7121 (English)
Notebook (Tel): +886-2-2890-7122 (English)
Desktop/Server (Tel): +886-2-2890-7123 (English)
Support Fax: +886-2-2890-7698
Web Site: www.asus.com.tw

ASUS COMPUTER INTERNATIONAL (America)

Address: 44370 Nobel Drive, Fremont, CA 94538, USA
General Fax: +1-510-608-4555
General Email: tmd1@asus.com

Technical Support

Support Fax: +1-510-608-4555
General Support: +1-502-933-8713
Web Site: www.asus.com
Support Email: tsd@asus.com

ASUS COMPUTER GmbH (Germany & Austria)

Address: Harkortstr. 25, 40880 Ratingen, BRD, Germany
General Fax: +49-2102-442066
General Email: sales@asuscom.de (for marketing requests only)

Technical Support

Support Hotline: MB/Others: +49-2102-9599-0
Notebook (Tel): +49-2102-9599-10
Support Fax: +49-2102-9599-11
Support (Email): www.asuscom.de/de/support (for online support)
Web Site: www.asuscom.de

FCC/CDC Statements

Federal Communications Commission

This device complies with FCC Rules Part 15. Operation is subject to the following two conditions:

- This device may not cause harmful interference, and
- This device must accept any interference received including interference that may cause undesired operation.

This equipment has been tested and found to comply with the limits for a Class B digital device, pursuant to Part 15 of the FCC Rules. These limits are designed to provide reasonable protection against harmful interference in a residential installation. This equipment generates, uses and can radiate radio frequency energy and, if not installed and used in accordance with manufacturer's instructions, may cause harmful interference to radio communications. However, there is no guarantee that interference will not occur in a particular installation. If this equipment does cause harmful interference to radio or television reception, which can be determined by turning the equipment off and on, the user is encouraged to try to correct the interference by one or more of the following measures:

- Reorient or relocate the receiving antenna.
- Increase the separation between the equipment and receiver.
- Connect the equipment to an outlet on a circuit different from that to which the receiver is connected.
- Consult the dealer or an experienced radio/TV technician for help.

WARNING! The use of shielded cables for connection of the monitor to the graphics card is required to assure compliance with FCC regulations. Changes or modifications to this unit not expressly approved by the party responsible for compliance could void the user's authority to operate this equipment.

Canadian Department of Communications

This digital apparatus does not exceed the Class B limits for radio noise emissions from digital apparatus set out in the Radio Interference Regulations of the Canadian Department of Communications.

This class B digital apparatus complies with Canadian ICES-003.

Contents

Disclaimer/Copyrights	ii
ASUS Contact Information	iii
FCC/CDC Statements	iv
Safety Precautions	vii
Electrical Safety	vii
Operation Safety	vii

Introduction

About this guide	I-1
Audience	I-2
Contents	I-2
Conventions	I-3
References	I-3
System Package Contents	I-4

Chapter 1: System Overview

System Overview	1-1
1.1 System Features	1-2
1.2 Front Panel Features	1-3
1.3 Rear Panel Features	1-4
1.4 Internal Features	1-5
1.5 LED Table	1-6

Chapter 2: Hardware Reference

Hardware Reference	2-1
2.1 Removing and installing chassis cover	2-2
2.2 Motherboard Placement	2-4
2.3 Central Processing Unit	2-5
2.4 System Memory	2-9
2.5 Fixed Device Bays	2-12
2.6 Hard Disk Drives	2-18

2.7	Screwless Expansion Card Slot	2-20
2.8	Long Card Support Guide	2-21
2.9	RAID Card	2-22
2.10	Hard Drive Blower	2-23
2.11	Chassis Fan	2-24
2.12	Connecting Cables	2-25
2.13	SCSI Backplane	2-26

Appendix A: Optional chassis roller-wheel

Chassis Roller-wheel Installation	A-2
--	------------

Appendix B: Power Modules

Redundant Power Modules	A-4
--------------------------------------	------------

Appendix C: Troubleshooting

Troubleshooting	A-9
------------------------------	------------

Safety Precautions

Electrical Safety

IMPORTANT

- Before installing or removing signal cables, ensure that the power cables for the system unit and all attached devices are unplugged.
- To prevent electrical shock hazard, disconnect the power cable from the electrical outlet before relocating the system.
- When adding or removing any additional devices to or from the system, ensure that the power cables for the devices are unplugged before the signal cables are connected. If possible, disconnect all power cables from the existing system before you add a device.
- If the power supply is broken, do not try to fix it by yourself. Contact an authorized dealer.

CAUTION

This product is equipped with a three-wire power cable and plug for the user's safety. Use the power cable with a properly grounded electrical outlet to avoid electrical shock.

Operation Safety

IMPORTANT

- Any mechanical operation on this server must be conducted by certified or experienced engineers.
- Before operating the server, carefully read all the manuals included with the server package.
- Before using the server, make sure all cables are correctly connected and the power cables are not damaged. If any damage is detected, contact your dealer as soon as possible.
- To avoid short circuits, keep paper clips, screws, and staples away from connectors, slots, sockets and circuitry.
- Avoid dust, humidity, and temperature extremes. Place the server on a stable surface.

Lined area for handwritten notes or signatures.

Introduction

“About This Guide” introduces the contents of this document. This part includes the target audience, chapter description, and conventions used. It also lists other sources of information that are not contained in this manual.

About this guide

Audience

This user guide is intended for system integrators, and experienced users with at least basic knowledge of configuring an entry-level server.

Contents

This guide contains the following parts:

1. Introduction: About this guide

This part introduces the contents of this document. It includes the target audience, chapter description, and conventions used. It also lists other sources of information that are not contained in this manual.

2. Chapter 1: System overview

This chapter describes the general features of the AP1700 system server. It includes sections on front panel and rear panel specifications.

3. Chapter 2: Hardware setup

This chapter lists the hardware setup procedures that you have to perform when installing system components.

4. Appendix A: Optional Chassis Roller-wheels

This appendix contains the installation procedure for the optional chassis roller-wheel units for the AP1700 server system.

5. Appendix B: Redundant Power Modules

This appendix contains detailed hardware operation and specifications of the AP1700 redundant power modules.

6. Appendix C: Troubleshooting

This appendix lists the common problems that you may encounter while using the AP1700 server. It lists the possible causes of the problems and offers solutions. You may refer to this part and try to solve simple problems before calling customer support.

Conventions

Symbols

To make sure that you perform certain tasks properly, take note of the following symbols used throughout this manual.



WARNING: Information to prevent injury to yourself when trying to complete a task.



CAUTION: Information to prevent damage to the components when trying to complete a task.



IMPORTANT: Information that you **MUST** follow to complete a task.



NOTE: Tips and information to aid in completing a task.

References

Refer to the following sources for additional information and for product and software updates.

1. **ASUS PR-DLS533 Motherboard User's Manual**

This manual contains detailed information about the PR-DLS533 motherboard.

2. **ASUS Websites**

The ASUS websites worldwide provide updated information on ASUS hardware and software products. The ASUS websites are listed in the ASUS Contact Information on page v.

3. **Optional Documentation**

Your product package may include optional documentation such as a CD-ROM manual, warranty flyers, and others that may have been added by your dealer. **NOTE:** These documents are not part of the standard server package.

System Package Contents

The following checklist enumerates the components included in the standard system package.

- 1) ASUS AS-35 Tower/5U Rackmount chassis
- 2) ASUS PR-DLS533 motherboard
- 3) 500W+500W redundant power supply
- 4) Backplane board (BP6LS-AS35)
- 5) CD-ROM drive (1 piece)
- 6) Floppy disk drive (1 piece)
- 7) Special heatsink with fan assembly (2 sets)
- 8) Hot swap SCSI hard disk drive tray (6 units)
- 9) AC power cord (2 pieces)
- 10) Support CD that includes drivers, utilities, ASUS System Monitoring Agent (ASMA) with the ASUS Server Web-based Management (ASWM)
- 11) Trend Micro Server Protect anti-virus software full user version CD enterprise edition
- 12) Motherboard user guide
- 13) System user guide
- 14) LSI SCSI controller user guide
- 15) ASMS (ASMA + ASWM) user guide
- 16) chassis roller wheels (4 sets)
- 17) Keys x 2
- 18) Screws and labels

Optional:

- 1) ASUS AS-35 5U rackmount rail kit
- 2) LSI MegaRAID 320-0 Zero channel RAID card



If any of the above items is missing, contact your dealer.

Chapter 1

This chapter describes the general features of the AP1700 system server. It includes sections on front panel, rear panel and internal specifications.

System Overview

1.1 System Features

The ASUS AP1700 server is a stylish server system featuring the ASUS PR-DLS533 motherboard. The server supports the Intel® Xeon™ processor in a 604-pin socket, and includes the latest I/O, LAN, and video technologies through the chipsets embedded on the motherboard.

The following are highlights of the server's many features:

- **Chassis:** Pedestal or rackmount 5U with removable front door bezel and chassis foot stand or roller-wheels.
- **Motherboard:** ASUS PR-DLS533
- **Chipset:** RCC Grand Champion LE Server 3.1 (GCLE), RCC Champion South Bridge 5.0 (CSB5), RCC Champion I/O Bridge 2.0 (CIOB-X2)
- **Memory:** Supports six 184-pin DDR DIMM sockets, PC2100/PC1600 registered ECC DDR DIMMs, 128MB to 12GB system memory.
- **Processor:** Support for two Intel® Xeon™ processor up to 2.8 GHz+ frequency.
- **Network Controller:** Intel® 82544GC Gigabit Ethernet controller, Intel® 82540EM Gigabit Ethernet controller
- **Drive Controller:** LSI 53C1030/64-bit/100MHz Dual Ultra-320 channels. Two UltraDMA 100 IDE channels.
- **Graphics:** ATI RAGE-XL PCI with 8MB PC-100 SDRAM video memory
- **Onboard IO:** 1 X PS/2 mouse port, 1 X PS/2 keyboard slot, 1 X serial ports, 1 X 15-pin VGA port, 1 X floppy drive slot, 2 X IDE ports, 4 X USB ports, 2 X RJ-45 LAN port, 2 X 68-pin SCSI connectors
- **Special IO:** IPMB connector, SM-Bus
- **Expansion:** 5 X 64-bit 3V PCI-X slots, 1 X 32-bit/33Mhz 5V PCI slot
- **Device Bays:** 6 X hot-swap trays for SCA SCSI hard drives, 3 X 5.25 inch bay, 1 X floppy disk drive bay.
- **Power Supply:** 500W redundant power supply.
- **Hardware Monitors:** Voltage, temperature, Automatic System Restart (ASR), fan speed.

1.2 Front Panel Features

The front panel allows easy access to the hard disk drives. The power and reset buttons, LED indicators, optical drive, floppy drive and two USB connectors are also located on the front panel. For future installation of 5.25 devices, there are two drive bays available. The front panel of the server is protected by a door and lock for added security.

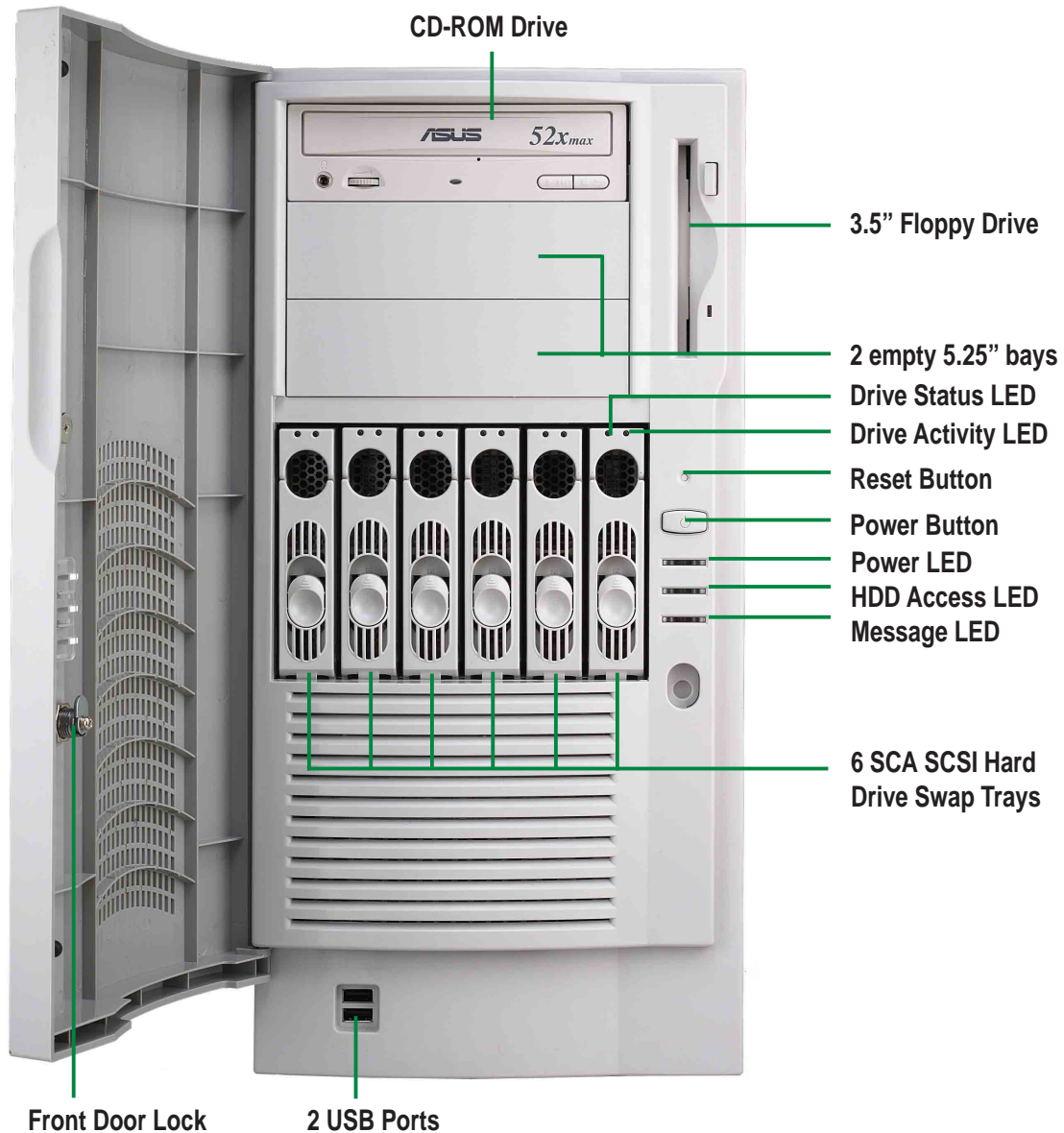

For more detailed information of each LED display, refer to "1.5 LED Table" on page 1-6.

1.3 Rear Panel Features

The server rear panel includes the connectors, the system devices, a chassis lock and six full-length expansion cards slot. The following shows the features on the rear side of the server.

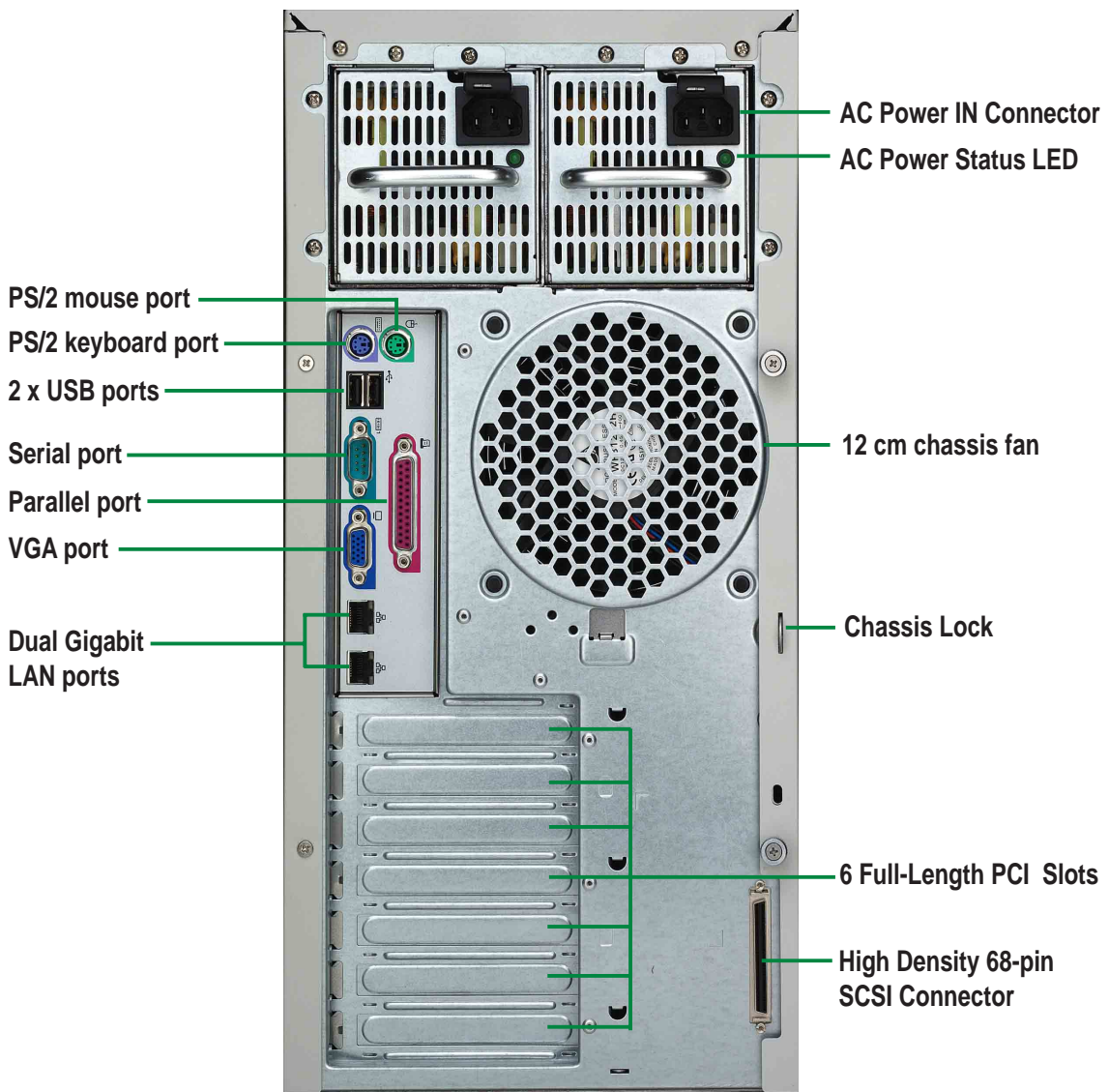

You may secure the chassis lock with an additional padlock or other security device for added server system security.

1.4 Internal Features



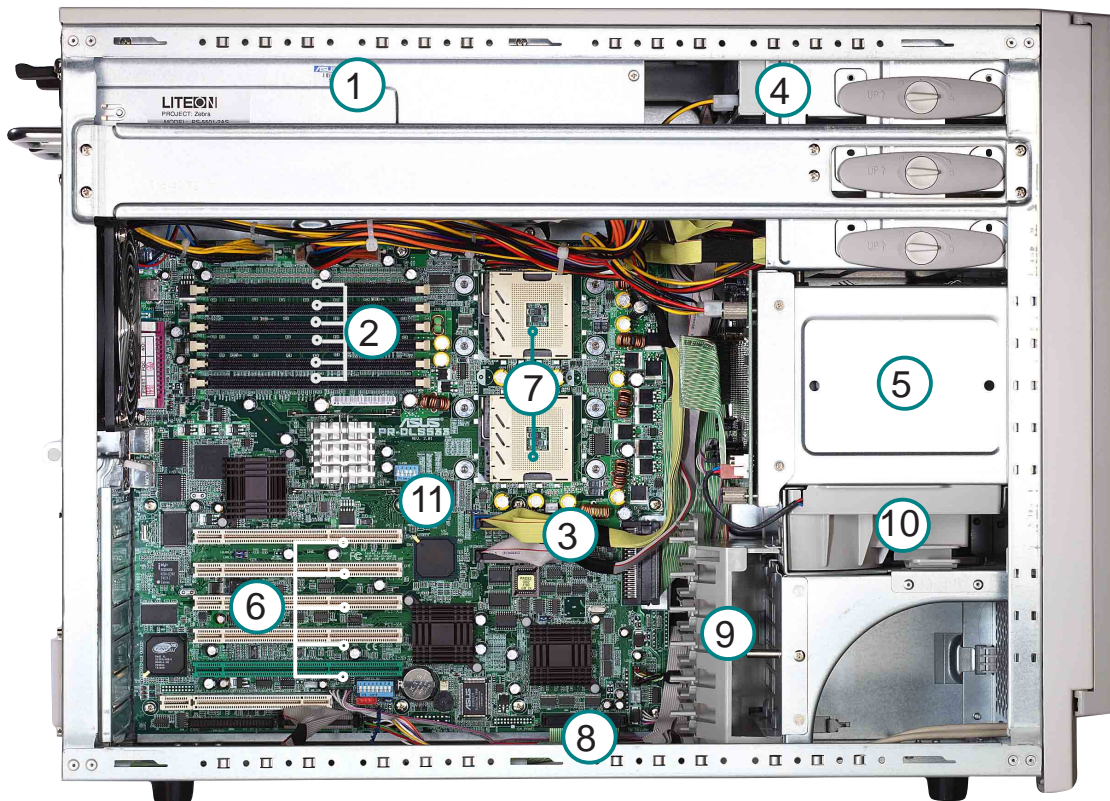

The standard components inside the server include the motherboard, power supply, floppy and CD-ROM drives, and cables. The picture below shows the standard components of the server.



- | | |
|--------------------------------|----------------------------------|
| 1. Redundant power supply cage | 6. 5 x 64 bit 3V PCI-X slots |
| 2. 6 x DDR DIMM sockets | 7. CPU sockets |
| 3. 2 x IDE cable | 8. Internal 68-pin SCSI cable |
| 4. 5 1/4" CD-ROM drive | 9. PCI Long Card support guide |
| 5. HDD hot swap modules | 10. 12 cm hot swap module blower |
| | 11. PR-DLS533 motherboard |

1.5 LED Table

The following table describes the LED display found on the front panel and rear panel of the AP1700 server system.

Icon	LED	Display	Description
① 	Drive Status LED	Green	HDD insert and Power status is good
		Red	HDD Fail
		Red blinking	HDD rebuilding (RAID card SAF-TE* function)
① 	Drive Activity LED	Blinking	HDD Read/Write data
② 	Power LED	ON	System power ON
		Blinking	Suspend Mode
③ 	HDD Access LED	OFF	No activity
		Blinking	Read/Write data in HDD
④ 	Message LED	OFF	Normal/No incoming event
		Blinking	ASMS indicate HW monitor event

*SCSI Access Fault - Tolerant Enclosure



Only RAID cards with SAF-TE feature is enabled with HDD rebuilding function.

Chapter 2

This chapter lists the hardware setup procedures that you have to perform when installing system components.

Hardware Setup

2.1 Removing and installing chassis cover

The chassis is designed for easy assembly and disassembly, making the installation of internal components very convenient.

2.1.1 Removing the chassis cover

1. Loosen the two thumb screws that secure the side cover.
2. Slide the chassis cover for about half an inch toward the rear until it is disengaged from the chassis.

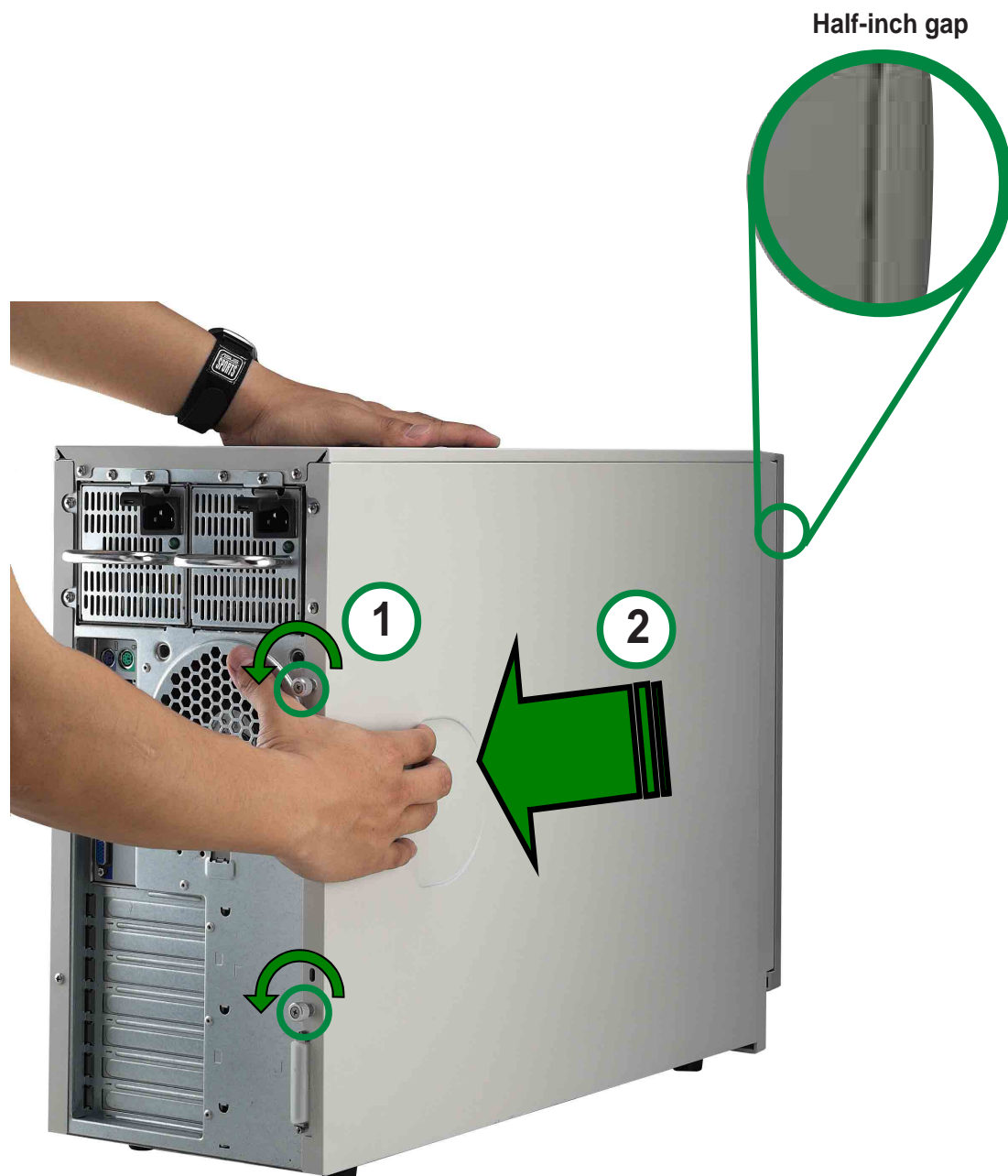

2.1.2 Installing the cover

1. Match and insert the hooks of the cover to the elongated holes on the side of the chassis. All the six hook (three each on the top and bottom) of the cover must properly fit the designated holes.
2. Slide the chassis cover for about half an inch towards the front until it snaps in place.
3. Tighten the thumb screws to secure the cover.

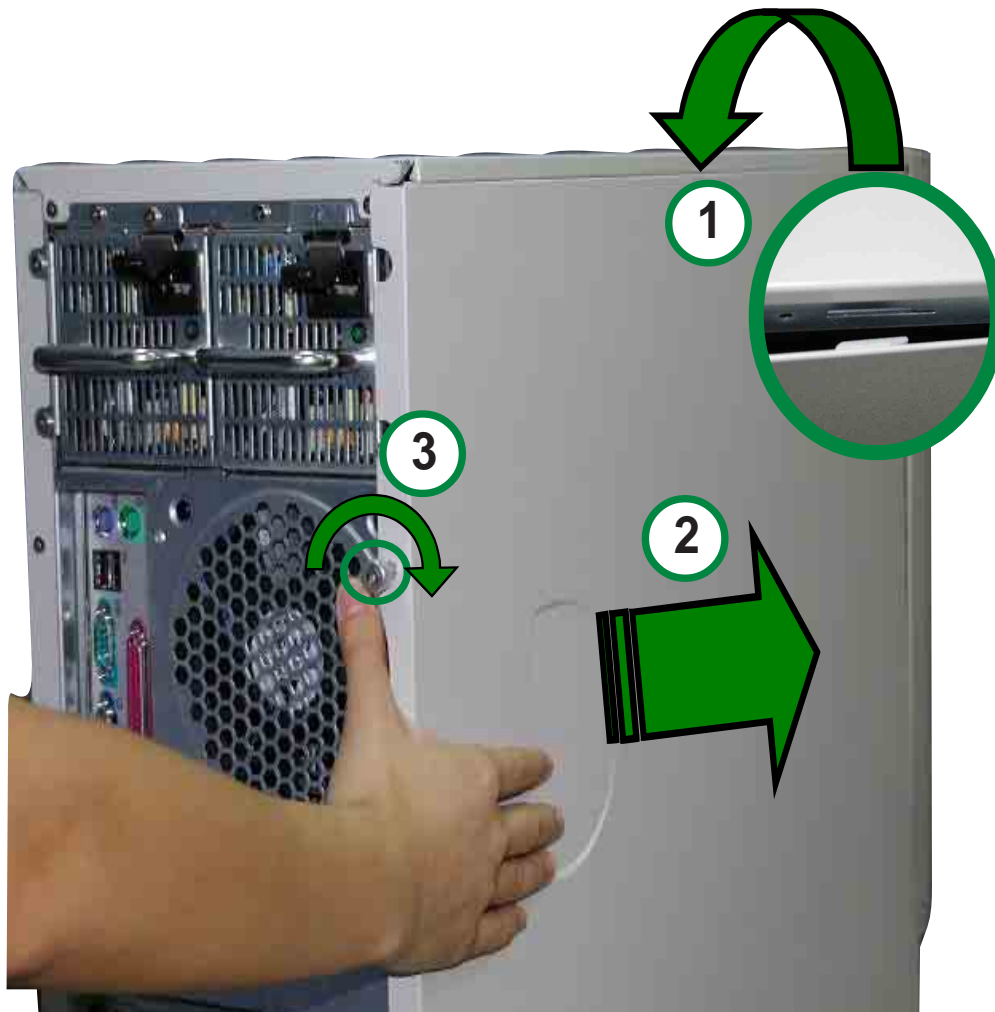

There are six (6) chassis guide hooks located on the upper side and lower side of the chassis cover, make sure all six are aligned properly in place.

2.2 Motherboard placement

Before you install the motherboard, study the configuration of your chassis to ensure that the motherboard fits into it. The PR-DLS533 uses the extended ATX form factor that measures 12 inches x 13 inches (30.5 x 33 cm).



Make sure to unplug the power cord before installing or removing the motherboard. Failure to do so may cause you physical injury and damage motherboard components.

Placement direction

When installing the motherboard, make sure that you place it into the chassis in the correct orientation. The edge with external ports goes to the rear part of the chassis as indicated in the image below.

Place this side towards the rear of the chassis

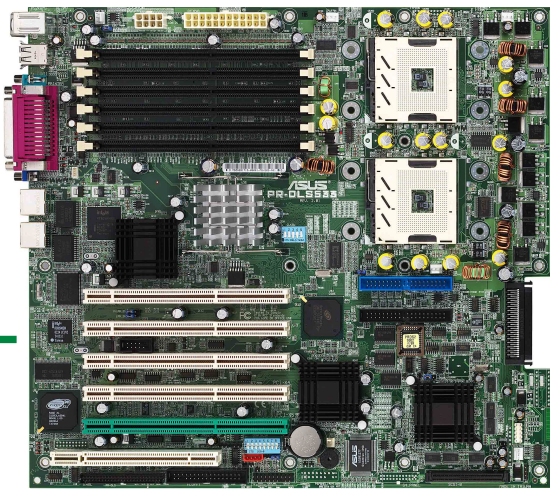

Motherboard Screws

Place thirteen (13) screws into the holes indicated by circles to secure the motherboard to the chassis. Do not overtighten the screws! Doing so may damage the motherboard.

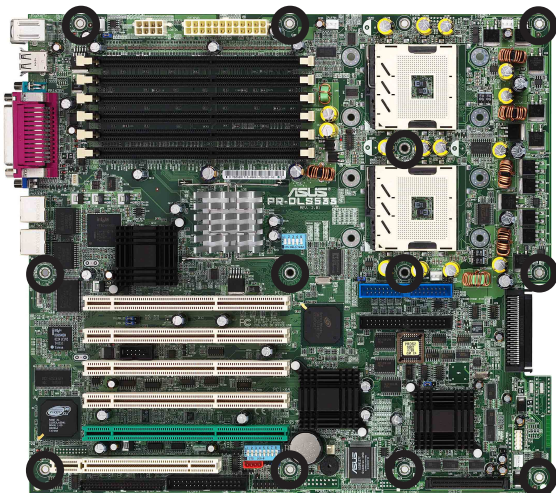

2.3 Installing the Central Processing Unit (CPU)



In the event of conflict between this instruction and other references cited herein, instructions in this system manual takes precedence.

2.3.1 Overview

The motherboard comes with dual surface mount 604-pin Zero Insertion Force (ZIF) sockets. The sockets are designed for the Intel Xeon Processor in the 604-pin package with 512KB L2 cache. The processor includes the Intel® NetBurst™ micro-architecture that features the hyper-threading technology, rapid execution engine, 533/400MHz system bus, and execution trace cache. Together, these attributes improve system performance by allowing higher core frequencies, faster execution of integer instructions, and data transfer rate of up to 4.26GB/s.

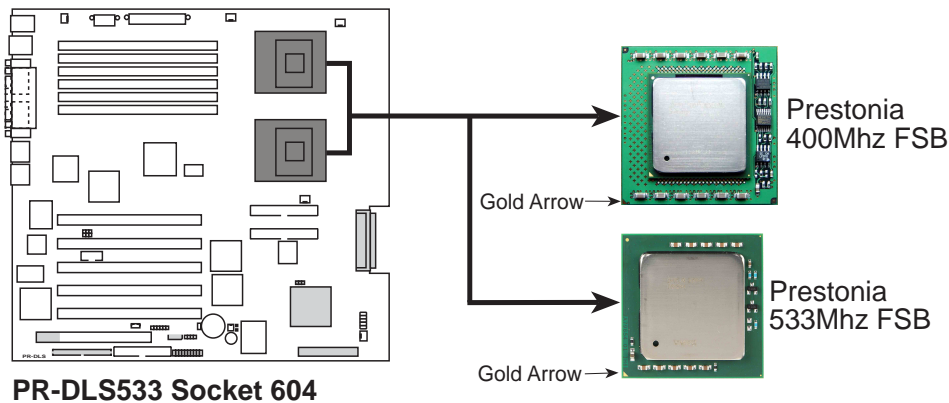

Note in the illustration that the CPU has a gold triangular mark on one corner. This mark indicates the processor Pin 1 that should match a specific corner of the CPU socket.



Incorrect installation of the CPU into the socket may bend the pins and severely damage the CPU!



1. The motherboard supports either one or two CPUs. If you are installing only one CPU, you **MUST** install it in CPU socket 1. Otherwise, the red motherboard LED will light up as warning.
2. Use Prestonia CPUs with the same FSB speed and specifications when installing on both CPU sockets.

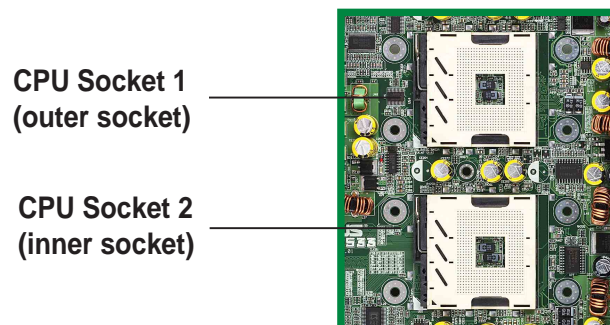

2.3.2 Installing the CPU



If you are installing only one CPU, install in CPU socket 1.

Follow these steps to install a CPU.

1. Locate the 604-pin ZIF sockets on the motherboard. Unlock the socket by pressing the lever sideways, then lift it up to at least 115° angle.



Make sure that the socket lever is lifted up to at least 115° angle, otherwise the CPU does not fit in completely.

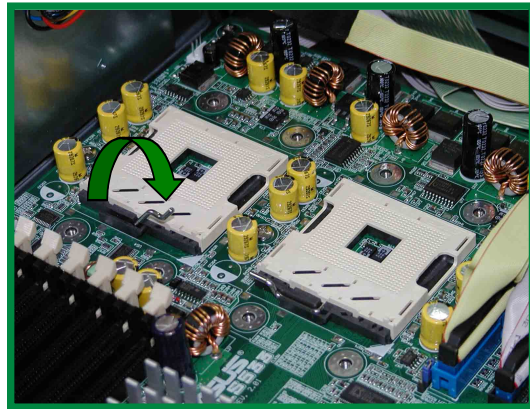

2. Position the CPU above the socket as shown.
3. Carefully insert the CPU into the socket until it fits in place.

Marked Corner

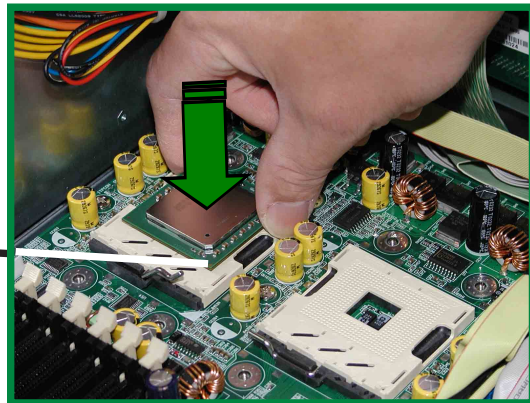

The CPU fits only in one correct orientation. **DO NOT** force the CPU into the socket to prevent bending the pins and damaging the CPU!

4. When the CPU is in place, press it firmly on the socket while you push down the socket lever to secure the CPU. The lever clicks on the side tab to indicate that it is locked.

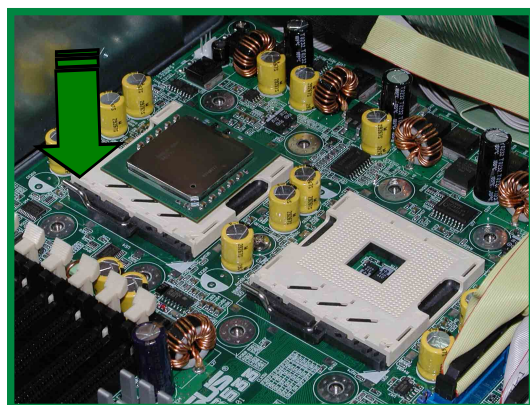

2.3.3 Installing the CPU heatsink with fan assembly

The Intel® Xeon™ processors require especially designed heatsink and fan assembly to ensure optimum thermal condition and performance.

Make sure that the heatsink with fan assembly is properly installed on the motherboard. A tilted or improperly installed heatsink with fan assembly can cause damage to motherboard CPU socket and/or CPU. Follow these steps to install the CPU heatsink and fan.

1. Place the heatsink and fan assembly on top of the installed CPU, making sure that it fits in the screw holes of the heatsink bracket found at the bottom of the CPU socket. (The heatsink bracket comes factory installed with the motherboard.)



2. Tighten all four (4) screws. Make sure all screws fit properly in place.



Take caution in tightening screws. Do not over-tighten screws, doing so may damage the motherboard!

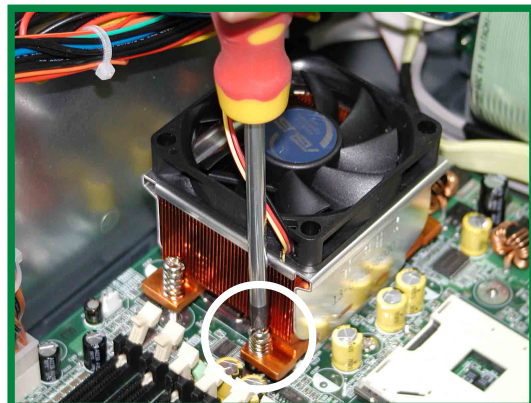

TIP: Follow the sequence shown: half-tighten the screw on one corner of the heatsink and fan, then the next screw on the other corner and so on, making a cross pattern. Repeat until all four screws are tightened properly.

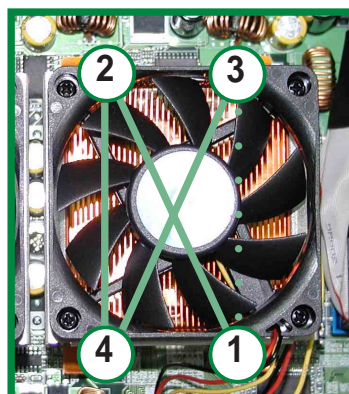

3. When the heatsink and fan assembly is in place, connect the fan cable to the fan connector on the motherboard labeled CPUFAN1.



The fan cable plug is slotted so it fits only in one orientation. If it doesn't fit completely, try reversing it.

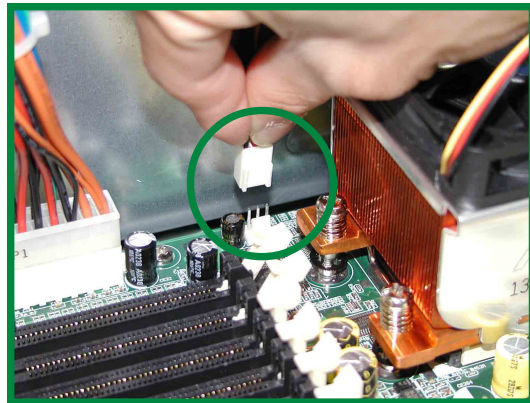

4. Make sure that the heatsink and fan assembly is stable in place and the fan power cable are connected properly.



Don't forget to connect the CPU fan cable. Hardware monitoring errors may occur if you fail to plug the fan cable.

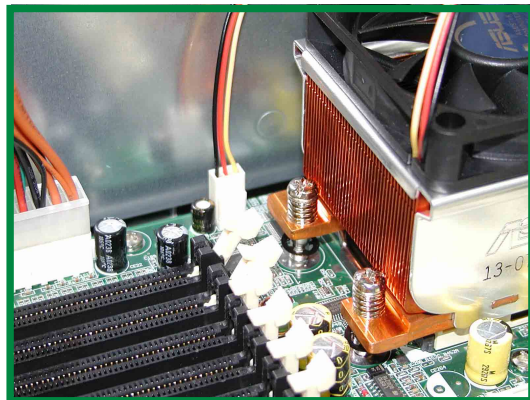

5. If you wish to install two CPUs, repeat the same steps for CPU socket 2.

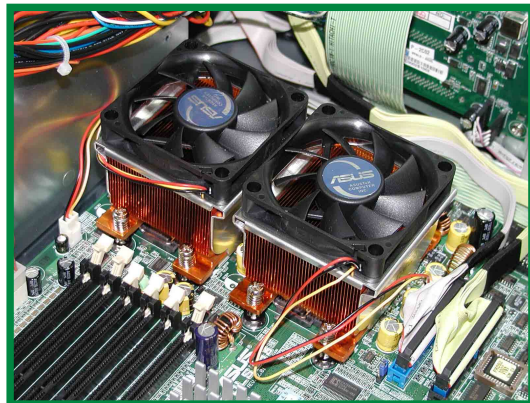

6. Use CPUFAN2 connector for the second CPU heatsink and fan assembly cable.

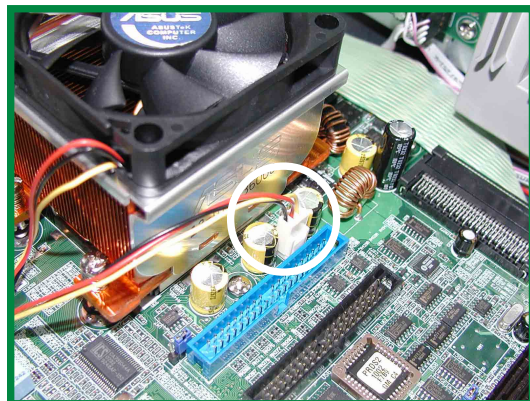

2.4 System memory

2.4.1 Overview

The motherboard comes with six Double Data Rate (DDR) Dual Inline Memory Module (DIMM) sockets. These sockets support up to 12GB system memory using 184-pin registered PC2100/1600 DIMMs with Serial Presence Detect (SPD) and Error Check and Correction (ECC).

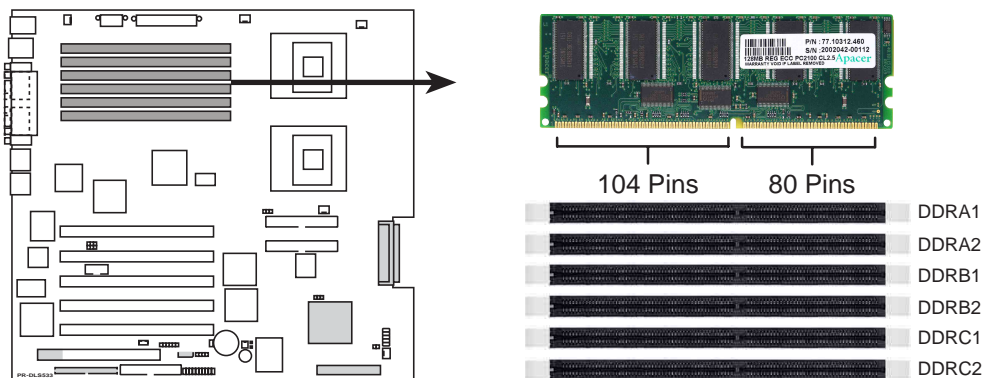

PR-DLS533 184-Pin DDR DIMM Sockets



A DDR DIMM is keyed with a notch so that it fits in only one direction. DO NOT force a DIMM into a socket to avoid damaging the DIMM.

The DDR SDRAM technology evolved from the mainstream PC66, PC100, PC133 memory known as Single Data Rate (SDR) SDRAM. DDR memory however, has the ability to perform two data operations in one clock cycle, thus providing twice the throughput of SDR memory. For example, a 200MHz DDR DIMM will support a 100MHz memory bus, and a 266MHz DDR DIMM will support a 133MHz memory bus.

DDR Data Transfer Rate		DDR Base Frequency
266MHz	➔	133MHz
200MHz	➔	100MHz

A DDR DIMM has the same physical dimensions as an SDR DIMM, but it has a 184-pin footprint compared to the 168-pin of the SDR DIMM. Also, a DDR DIMM is single notched while an SDR DIMM is double notched. Therefore, a DDR DIMM is not backward compatible with SDR, and should be installed only in a socket specially designed for DDR DIMMs.

2.4.2 Memory Configurations

The motherboard supports system memory of up to 12GB in a two-way interleaved configuration. As a rule, this configuration requires that you install identical DDR DIMMs (exactly the same type and size) in pairs for optimum performance. For example, if you installed a 512MB module into DDRA1, you must install the same type of 512MB module into DDRA2. The same rule applies to pairs DDRB1/DDR B2 and DDRC1/DDRC2.

The only exception to the above rule allows you to install one DIMM into DDRA1 socket (the socket closest to the ATX power connector). Installing a single DIMM into any other socket would not work.

The following table lists the DIMM socket pairs and the memory modules that you can install.

Memory configuration table

DIMM Socket	184-pin ECC DDR DIMM	Total Memory
DDRA1	SDRAM 128MB, 256MB, 512MB, 1GB, 2GB	x1
DDRA2	SDRAM 128MB, 256MB, 512MB, 1GB, 2GB	x1
DDR B1	SDRAM 128MB, 256MB, 512MB, 1GB, 2GB	x1
DDR B2	SDRAM 128MB, 256MB, 512MB, 1GB, 2GB	x1
DDRC1	SDRAM 128MB, 256MB, 512MB, 1GB, 2GB	x1
DDRC2	SDRAM 128MB, 256MB, 512MB, 1GB, 2GB	x1
Total System Memory (Max. 12GB) =		



The system chipset only supports PC2100/1600 registered ECC DIMMs. Make sure to use only the specified DIMM types for stable system operation.

2.4.3 Installing a DIMM



Make sure to unplug the power supply before adding or removing DIMMs or other system components. Failure to do so may cause severe damage to both the motherboard and the components.

Follow these steps to install a DIMM.

1. Unlock a DIMM socket by pressing the retaining clips outward.
2. Align a DIMM on the socket such that the notch on the DIMM matches the break on the socket.

Unlocked Retaining Clip

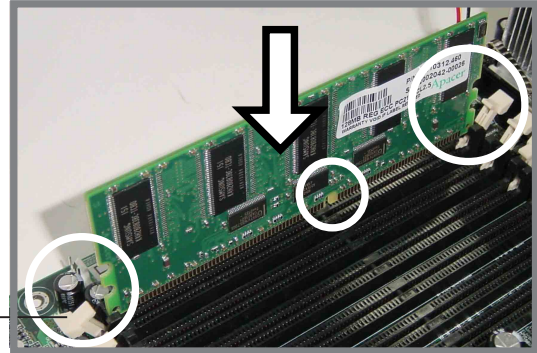

3. Firmly insert the DIMM into the socket until the retaining clips snap back in place and the DIMM is properly seated.

Locked Retaining Clip

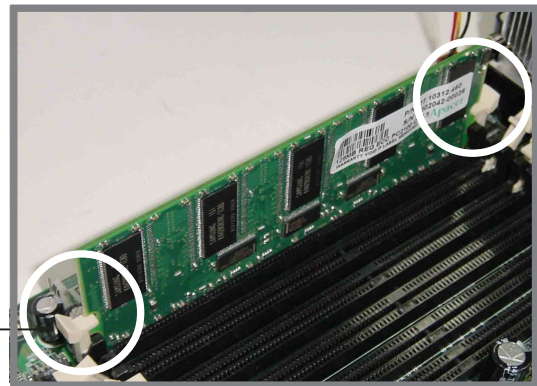

2.4.4 Removing a DIMM

Follow these steps to remove a DIMM.

1. Simultaneously press the retaining clips outward to unlock the DIMM.
2. Remove the DIMM from the socket.



Support the DIMM lightly with your fingers when pressing the retaining clips. The DIMM might get damaged when it flips out with extra force.

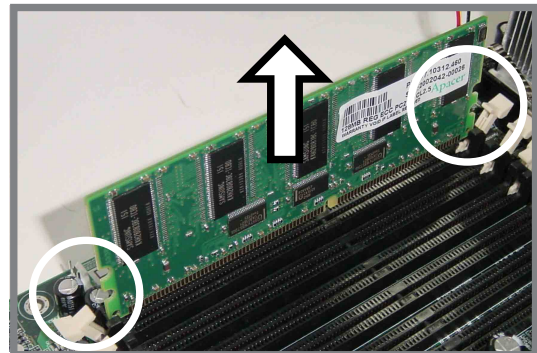

2.5 Fixed Device Bays

2.5.1 Overview

The fixed device bay are cinched by screwless locks for device placement convenience. An IDE CD-ROM drive is installed on the uppermost bay and two free bays are available for installation of additional storage devices like optical disc drives or tape drives.

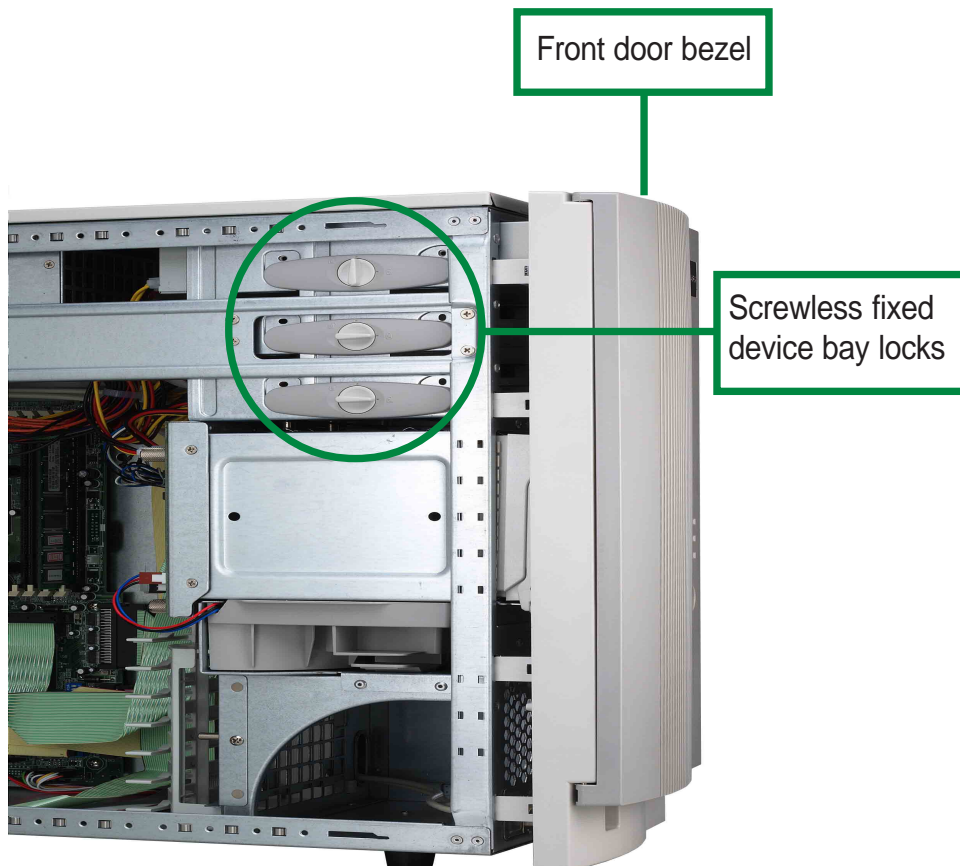

2.5.2 Installing a 5.25 device



Make sure to unplug the AC power supply before adding or removing any 5.25 fixed device or other system components. Failure to do so may cause severe damage to both the motherboard and the system components.

1. Use thumbs or a flat-head screw driver to detach the hooked tabs from the left side of the front panel.

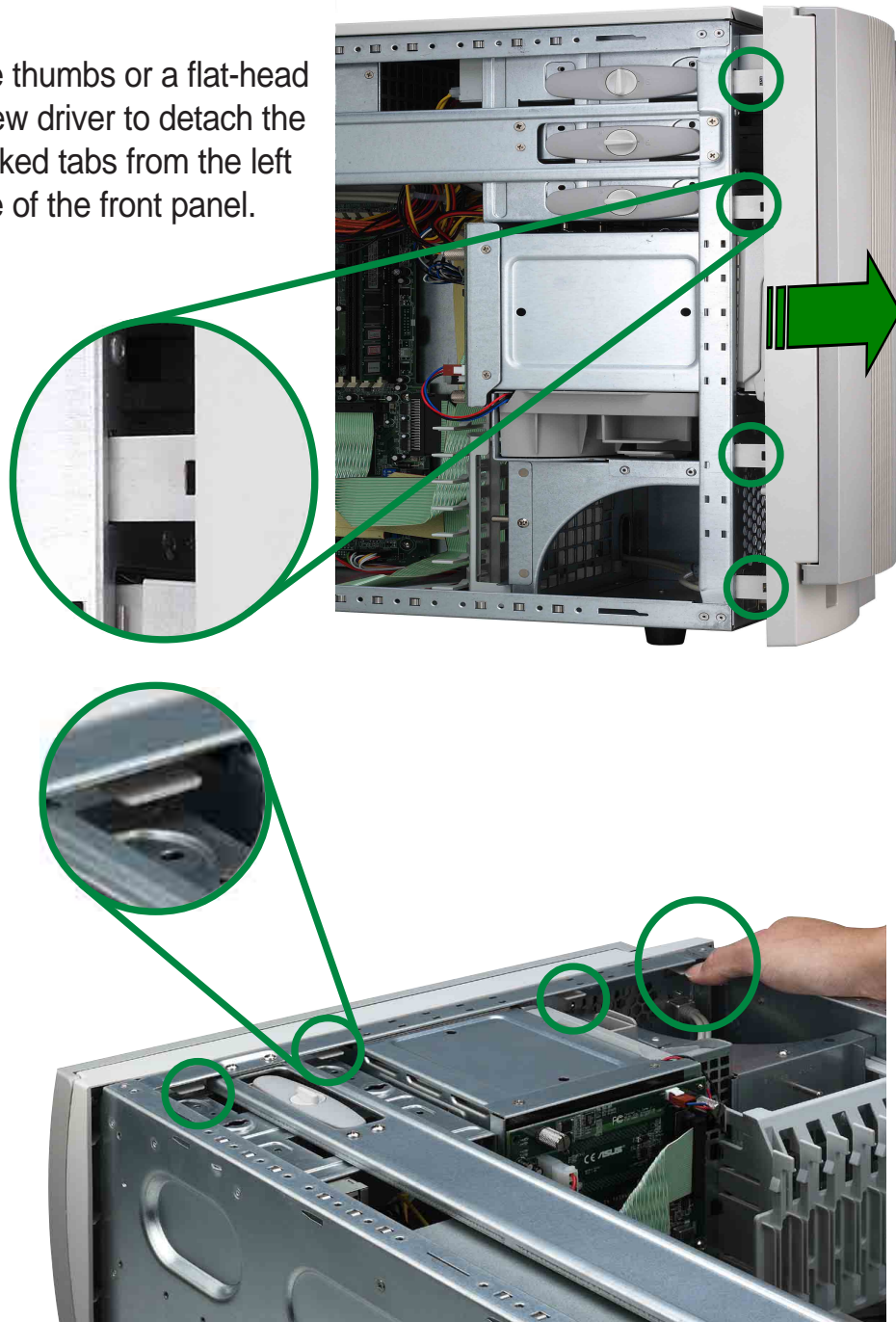

Take caution in removing the front panel cover. Do not use too much force when installing or removing items.

2. Remove the appropriate metallic bay panel cover of the bay slot you want to install your device.

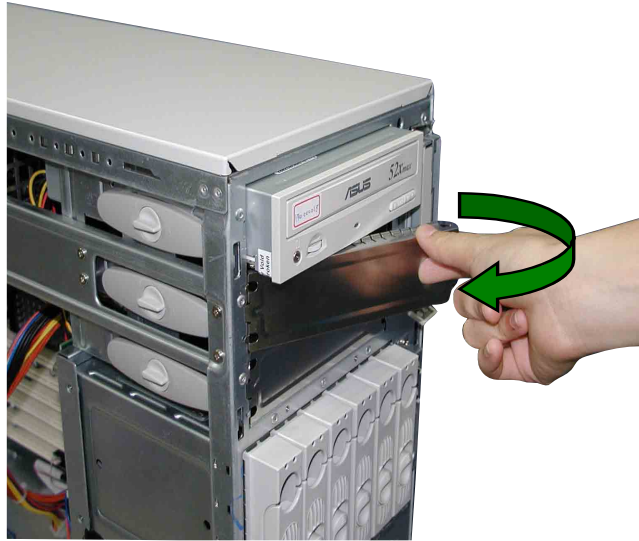

3. From the side of the drive bay, unlock and remove the screwless drive bay lock by turning the knob 45° counter-clockwise until it clicks on the reference point near the “unlocked icon”.

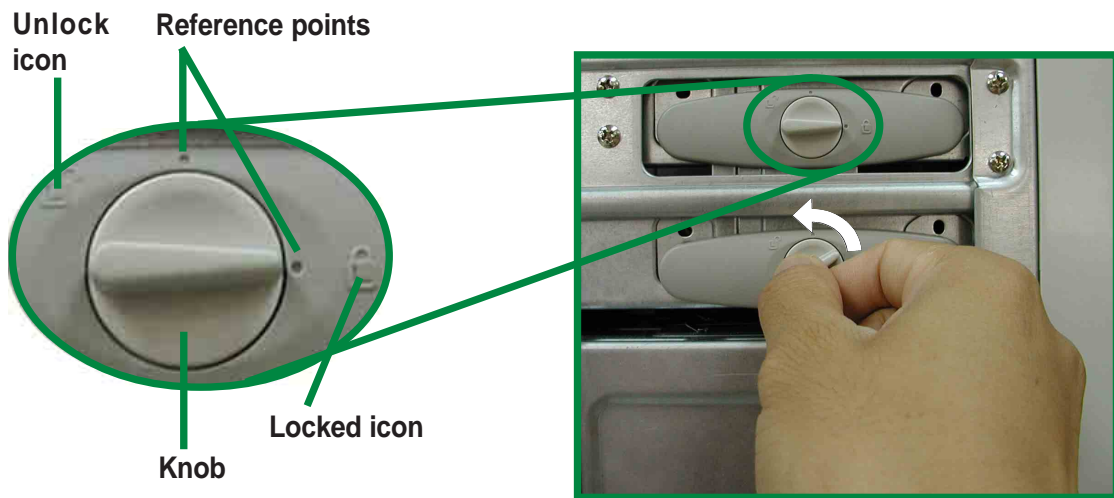

4. When released, pull- out the lock and set it aside.

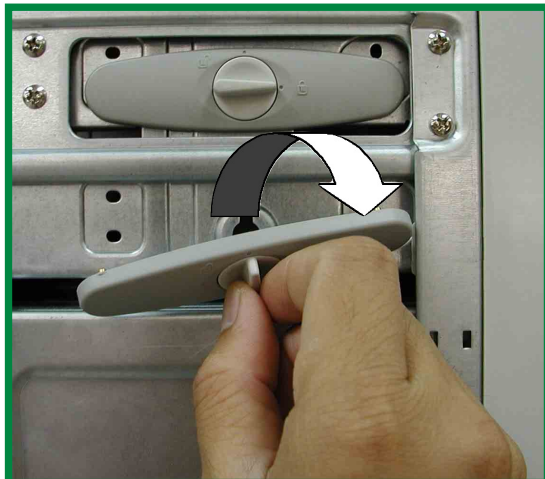

-
- Carefully insert device (such as CD/DVD-ROM drive) into the selected bay.

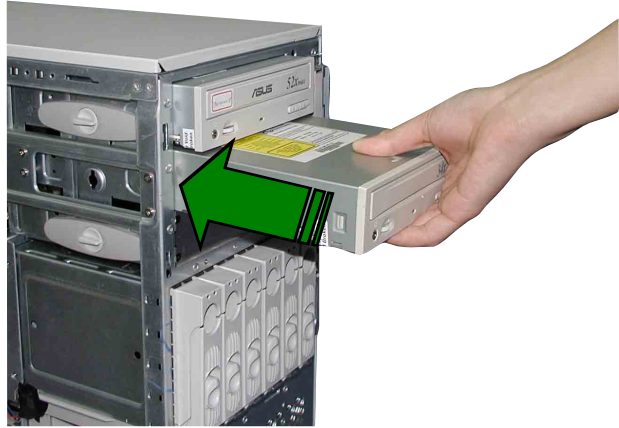

- Secure the drive to the bay using the screwless drive bay lock that you removed earlier.

- Match the two pegs on the lock to the holes on the drive bay.



- Turn the knob 45° clockwise until it clicks on the reference point near the "locked icon".



- Remove the appropriate plastic bay cover on the front panel.

Front Panel door hinges

Front Panel plastic bay cover

- Fasten the four (4) front panel hinges to the slotted chassis holes then close the front panel cover.

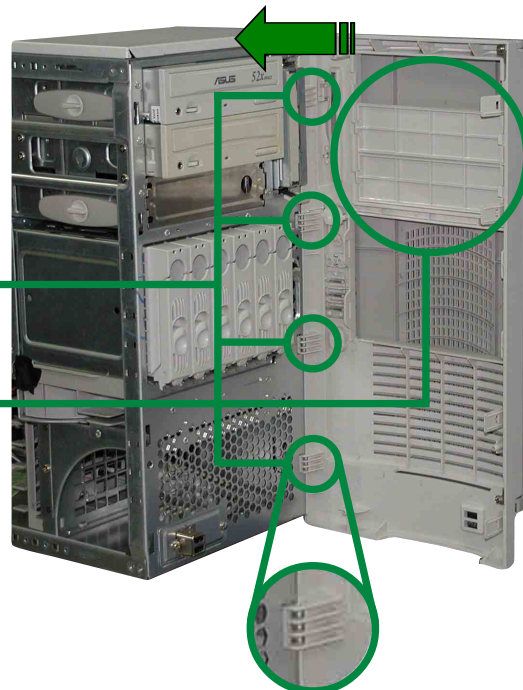

2.5.3 Removing floppy disk drive tray

Follow the following procedures to remove the floppy disk drive tray.

1. Remove the front cover panel. Refer and perform step #1 in section “2.5.2 Installing a 5.25 device” on page 2-13.
-

2. Remove the two screws that secure the right side chassis cover.



3. Pull out and detach the right side chassis cover. Set aside.

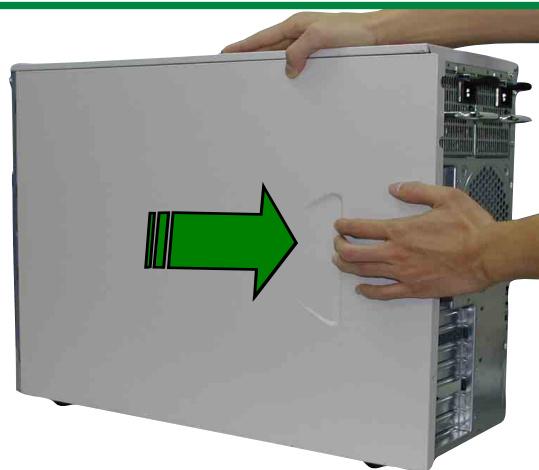

4. Locate the floppy disk drive cable and power connectors.

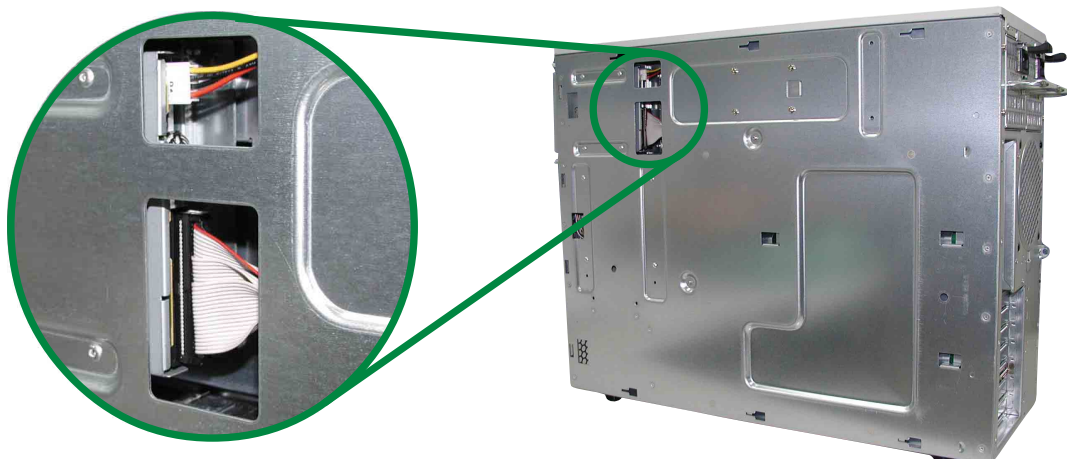

-
- 4.a Carefully detach the floppy disk drive cable.



- 4.b Carefully detach the floppy disk drive power cable.



-
5. Pull out the floppy disk drive tray while squeezing the two tabs together.

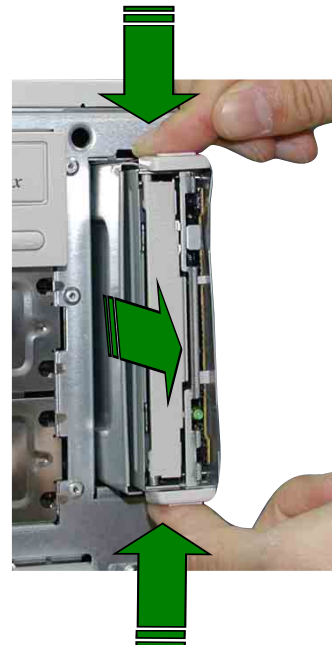

Floppy disk drive tray

2.6 Installing a Hard Disk Drive

The server comes with six externally accessible drive bays. In each of the drive bays is a removable tray for mounting an SCA SCSI hard disk drive.

To release the drive bay, follow these steps.



1. Lift the spring lock upwards, then pull the tray lever outwards.



2. When the tray lever is pulled down, the tray will eject slightly. Pull the tray outwards on the tray lever.

2.6.1 Placing an SCA SCSI Hard Drive to tray

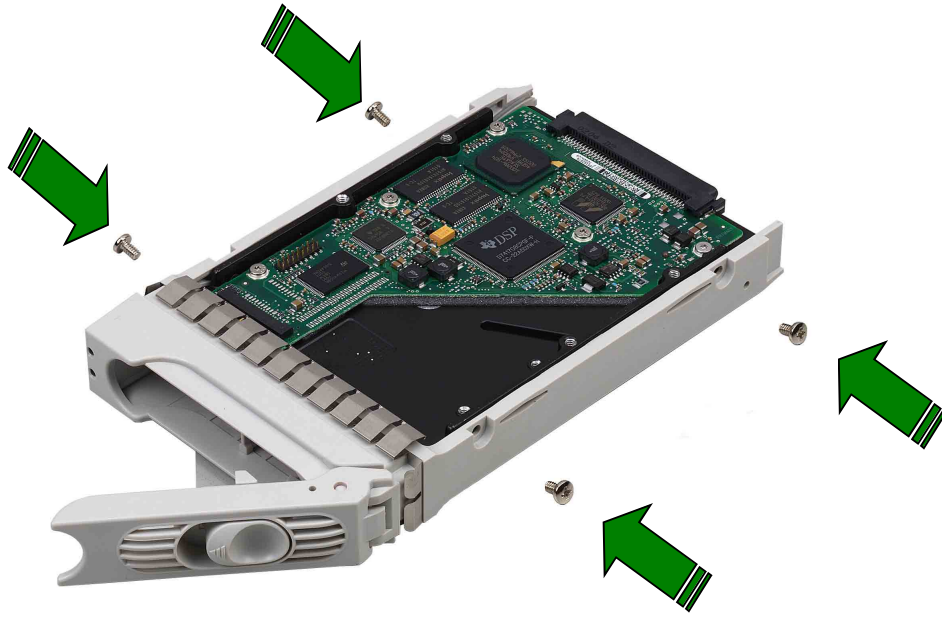

1. Place an SCA SCSI hard drive into drive tray and secure the drive using the bundled four (4) screws.

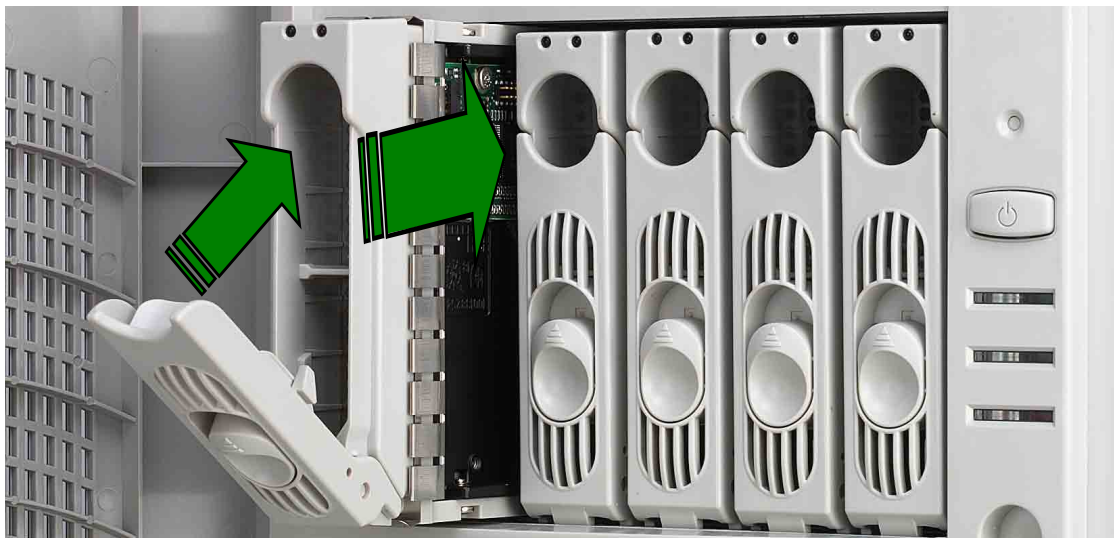

2. After the drive is secured to the tray, carefully insert the drive into the bay.
3. Push the tray all the way to the depth of the bay until it fits.
4. Push the tray handle back into place until you hear a locking sound.



Make sure that the HDD tray is completely in place before you push the handle back to avoid damaging the drive and the tray.

2.7 Screwless Expansion Card Slot

The AP1700 chassis is designed with a screwless expansion card slot for Personal Computer Interface (PCI) card installation convenience.

To add or remove expansion cards, follow these steps:

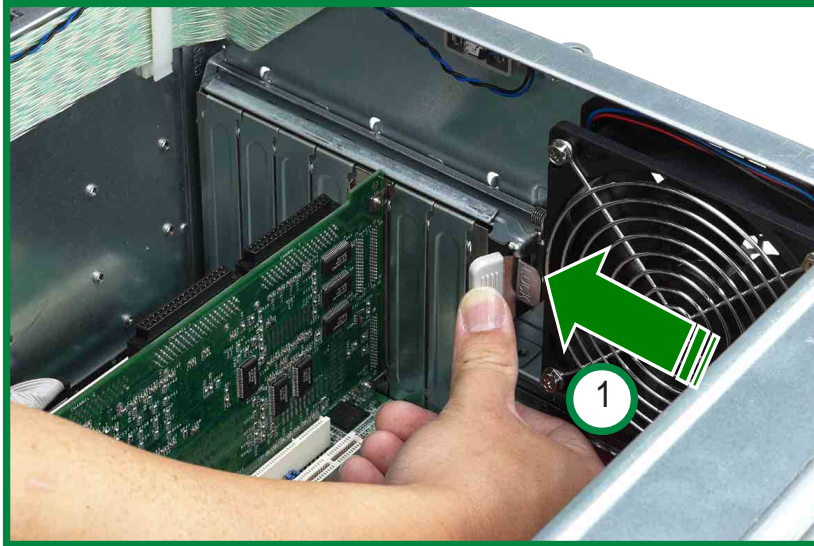

1. To open, push the lever to the left using your thumb to release the spring lock.

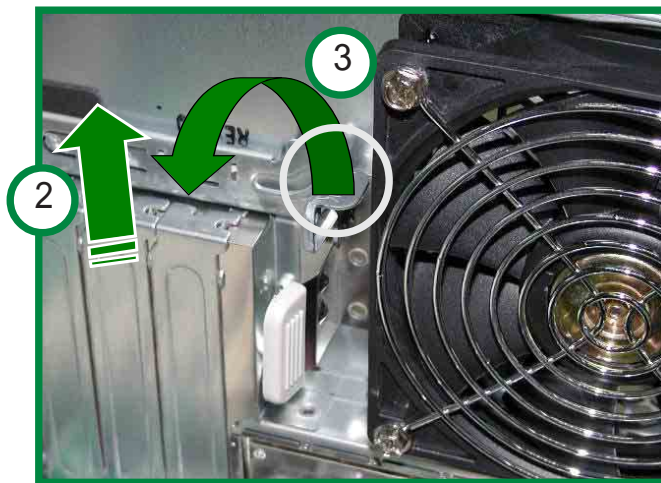

2. To remove the metal plate of selected slot, pull the metal plate upwards.



Take caution in handling the metal plate, the sharp edges may cause body injury.

3. To lock, make sure that all expansion cards are properly inserted in the slots, then pull the spring lock lever to fasten the expansion cards in place.

2.8 Long Card Support Guide

The long card support guide secures that long expansion cards are positioned firmly in place.

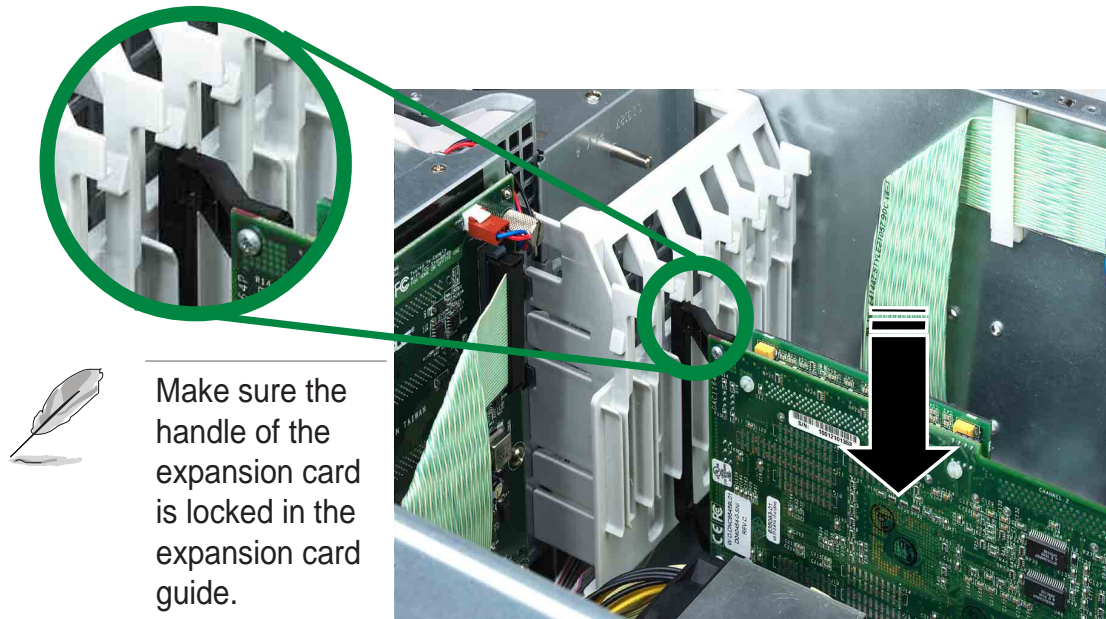

To install a long expansion card, follow these steps.

1. Before installing the expansion card, read the documentation that came with it and make the necessary hardware settings.
2. Remove the system chassis cover.
3. Remove the bracket opposite the PCI slot. Refer to “2.7 Screwless Expansion Card Slot” on page 2-18 for more details.
4. Align the long card connector with the slot and press firmly until the card is completely seated on the slot.
5. Secure the card to the chassis by locking the expansion card slot screwless lock. Refer to “2.7 Screwless Expansion Card Slot” on page 2-18 for more details.
6. Replace the chassis cover.
7. Set up the BIOS if necessary.
8. Install the necessary software drivers for your expansion card.



Make sure to unplug the power cord before installing or removing expansion cards from the slot. Failure to do so may cause you physical injury, damage the expansion card or other motherboard components.

2.9 RAID Card (optional)

The following picture shows the proper cabling of an installed RAID card. It is recommended that the given RAID card installation specification and settings are followed for easier handling and maintenance.

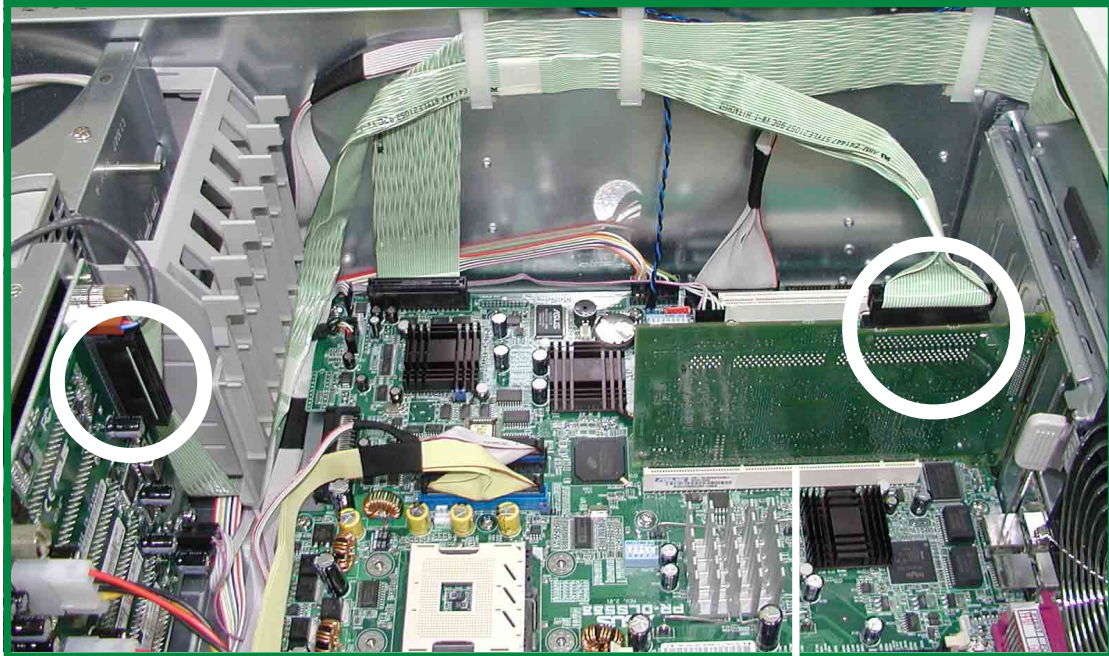

RAID Card

2.9.1 PCI Slot speed (MHz) assignments

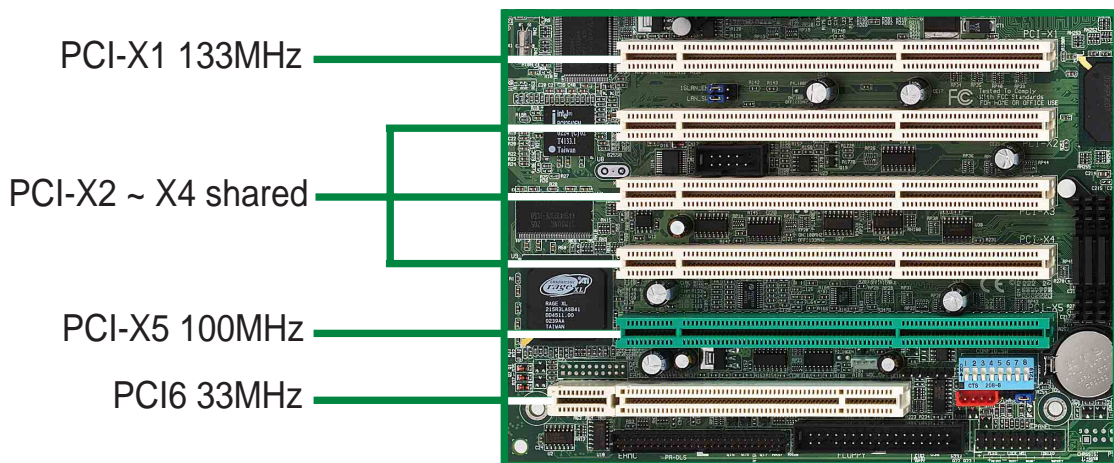

- PCI-X2 ~ PCI-X4 BUS speeds vary depending on the number of PCI cards installed. One (1) PCI card plugged in any of PCI-X2~X4 slots will get a maximum speed of 133MHz, two (2) PCI cards installed will get a maximum speed of 100MHz and three (3) PCI cards will get maximum speed of 66MHz.
- PCI-X5 slot supports LSI MegaRAID U320-0 Zero Channel RAID

2.10 Hard Drive Blower

The hard drive module is cooled by a blower mounted under the hot swap bays. The drive blower status can be monitored through the ASUS® Server Management Software (ASMS) for remote management convenience.

2.10.1 Removing the hard drive blower

To remove the hard drive blower, follow these steps.

1. Remove the hard drive blower 3-pin power cable (FAN1) from the SCSI backplane.

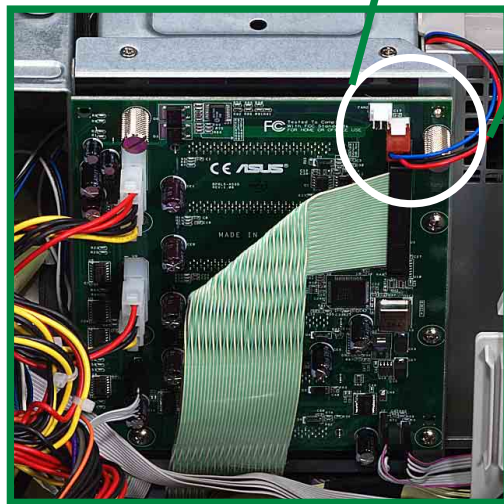

2. Pull out the blower housing while squeezing the two tabs together.

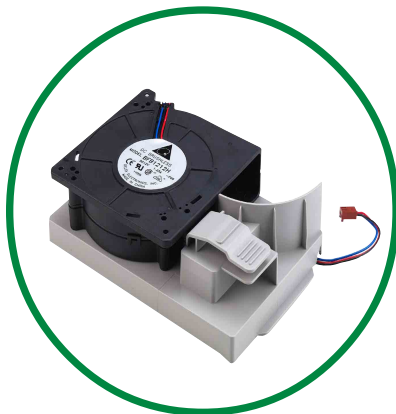

Blower Power Cable

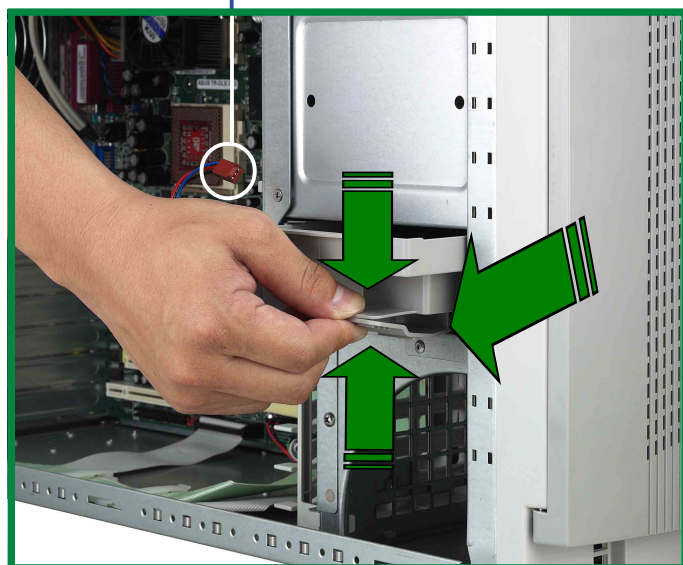

2.11 Chassis Fan

The chassis is cooled by a 12-cm chassis fan mounted at the rear panel. The chassis fan status can be monitored remotely through the ASUS® Server Management Software (ASMS).

2.11.1 Removing the 12-cm chassis fan

To remove the 12-cm chassis fan, follow these steps.

1. Remove the 12-cm chassis fan 3-pin power cable (SYSFAN3) from the motherboard.

12-cm chassis fan power cable (SYSFAN3)

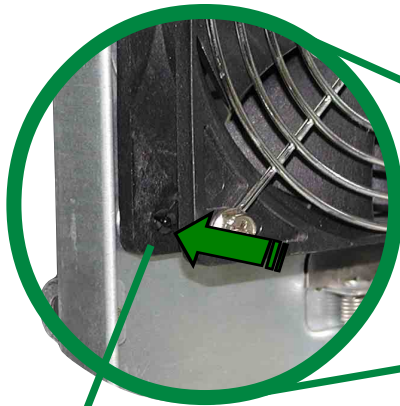
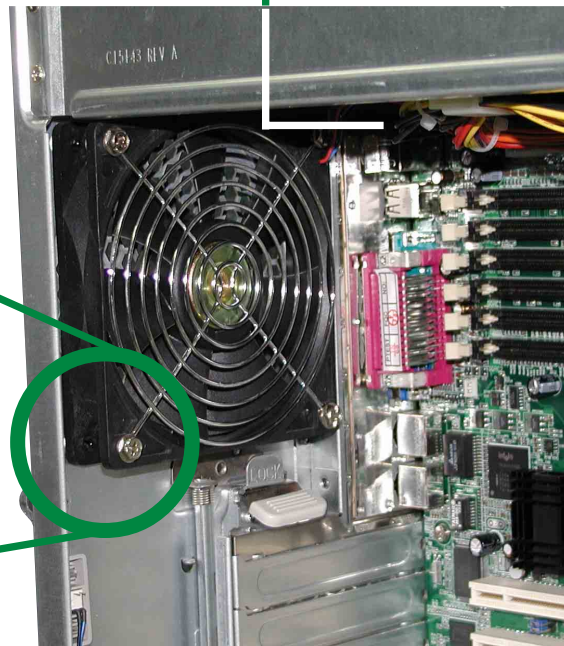

chassis fan pin-locks

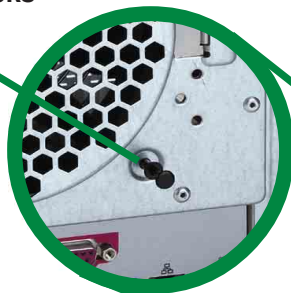

2. Release all four (4) pin-locks by squeezing the pin tail and pushing the pin to the rear panel.

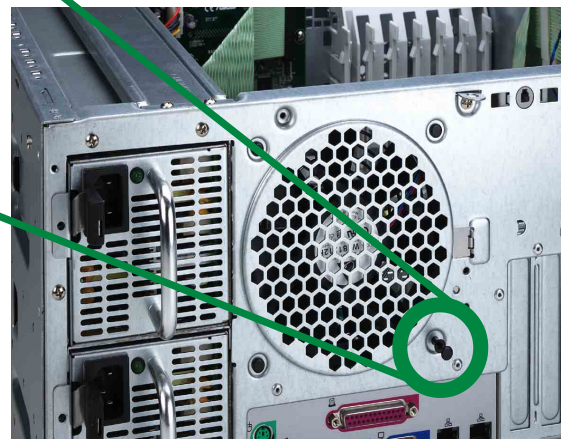

3. Pull out the 12-cm chassis fan.

2.12 Connecting Cables

Most of the cables in the server are already pre-connected to their respective connectors. The following illustrates the corresponding components that are connected to these connectors.

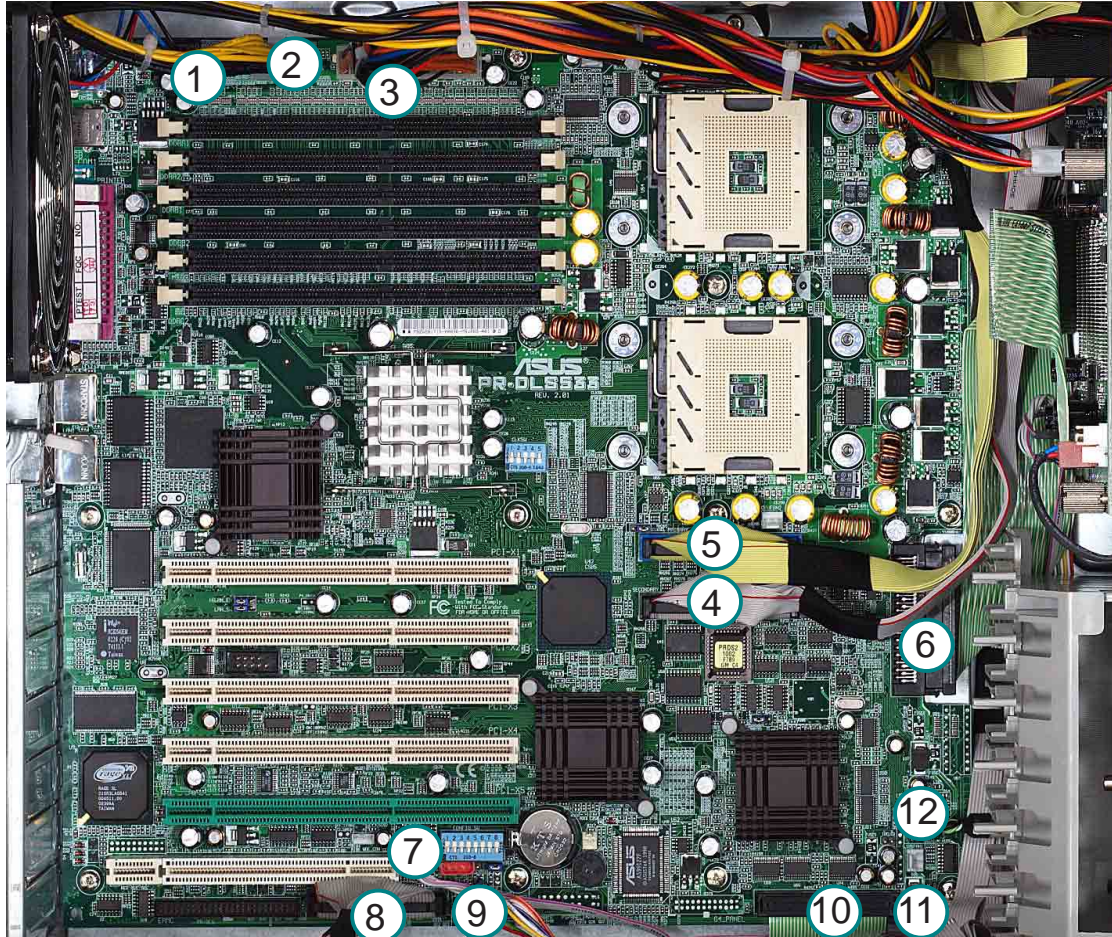

- | | |
|--|---|
| 1. Chassis fan (SYSFAN3) | 7. SMBUS Panel to backplane |
| 2. 8-pin 12V AUX Power | 8. Floppy Disk Drive |
| 3. 24-pin ATX Power | 9. 20-pin system panel |
| 4. Secondary IDE | 10. SCSI Channel B connect to external SCSI connector |
| 5. Primary IDE | 11. HDD Access cable |
| 6. SCSI Channel A connect to backplane | 12. Front USB Connector |



These are not the names of the connectors. Refer to the motherboard user's manual for detailed information on the motherboard connectors.

2.13 SCSI Backplane

2.13.1 Overview

The SCSI backplane assembly defines the distribution of power and signals to the system and its peripherals. Also, the SCSI backplane provides physical and electrical protection in case the current output tipped over the safety limit.

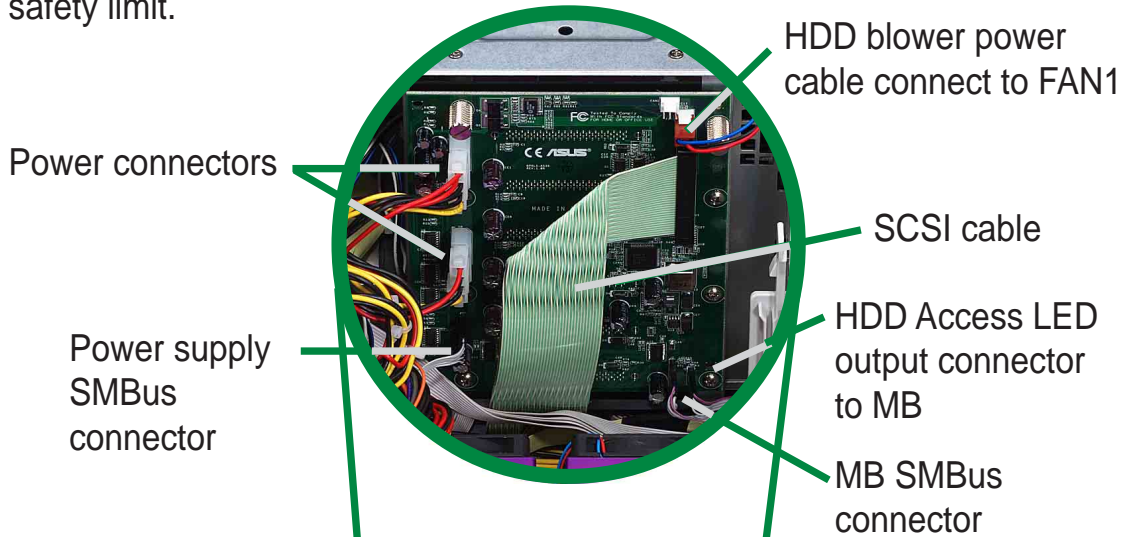

2.13.2 SCSI Backplane frontside and backside

The SCSI backplane assembly of this server is comprised of one SCSI board (BP6LS-AS35) with 68-pin SCSI connector, two 12V power inputs, two fan connectors (FAN1, FAN2) and three jumper connectors (J1, J2, J3). This configuration allows SCA SCSI hard disk drives to be docked into the server.

A. SCSI Backplane Frontside

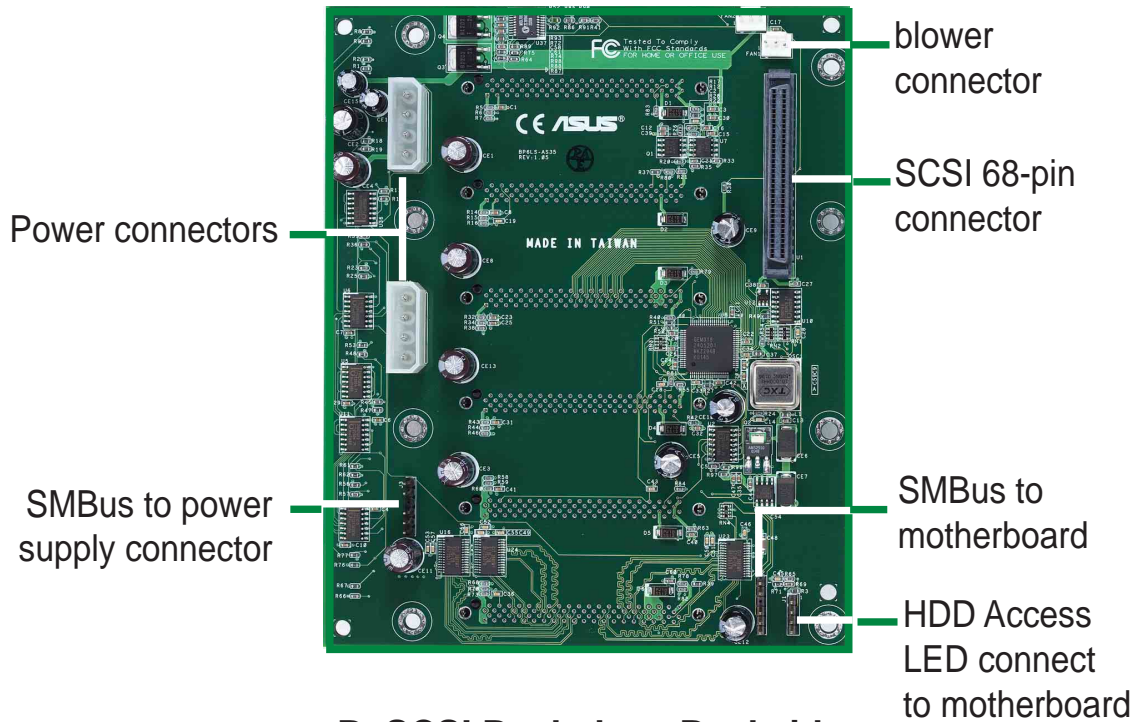

B. SCSI Backplane Backside

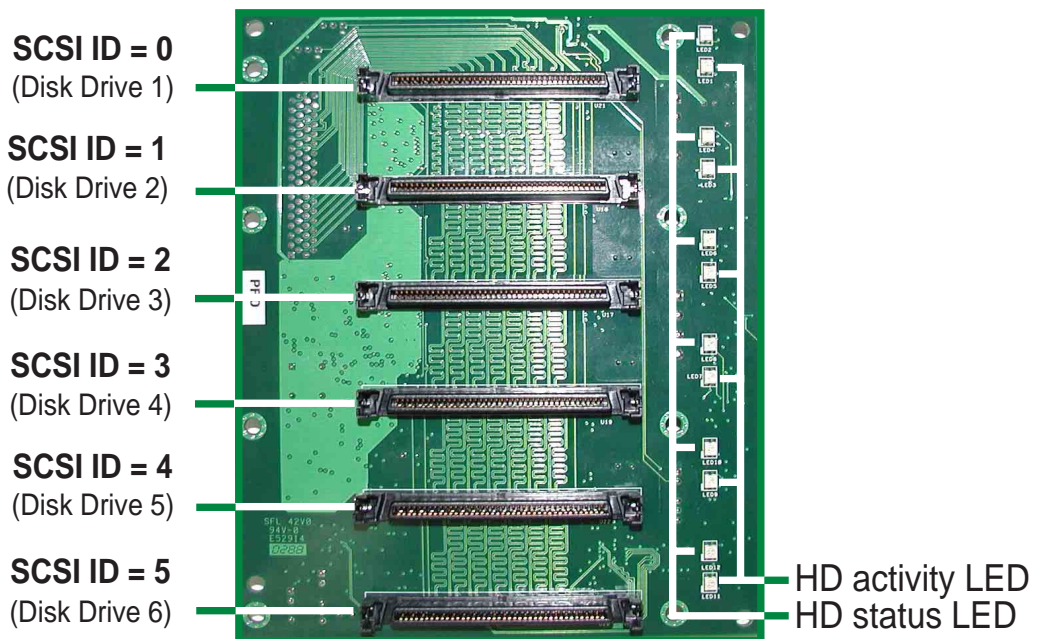

Refer to “1.5 LED Table” on page 1-6, for detailed SCSI Backplane LED display descriptions.

This appendix contains the installation procedure for the optional chassis roller-wheel units for the AP1700 server system.

Chassis Roller-wheel

Chassis Roller-wheel Installation

The AP1700 comes with an optional roller-wheel for the chassis for server transport convenience. Follow these easy steps to mount the chassis roller-wheels.

To install the roller-wheels, follow these steps.

1. Lay chassis on a side-lying position.
2. Affix each plastic rubber wheel unit by mounting its screws on designated slots at the bottom of the chassis.
3. Make sure the screws are tightened accordingly.

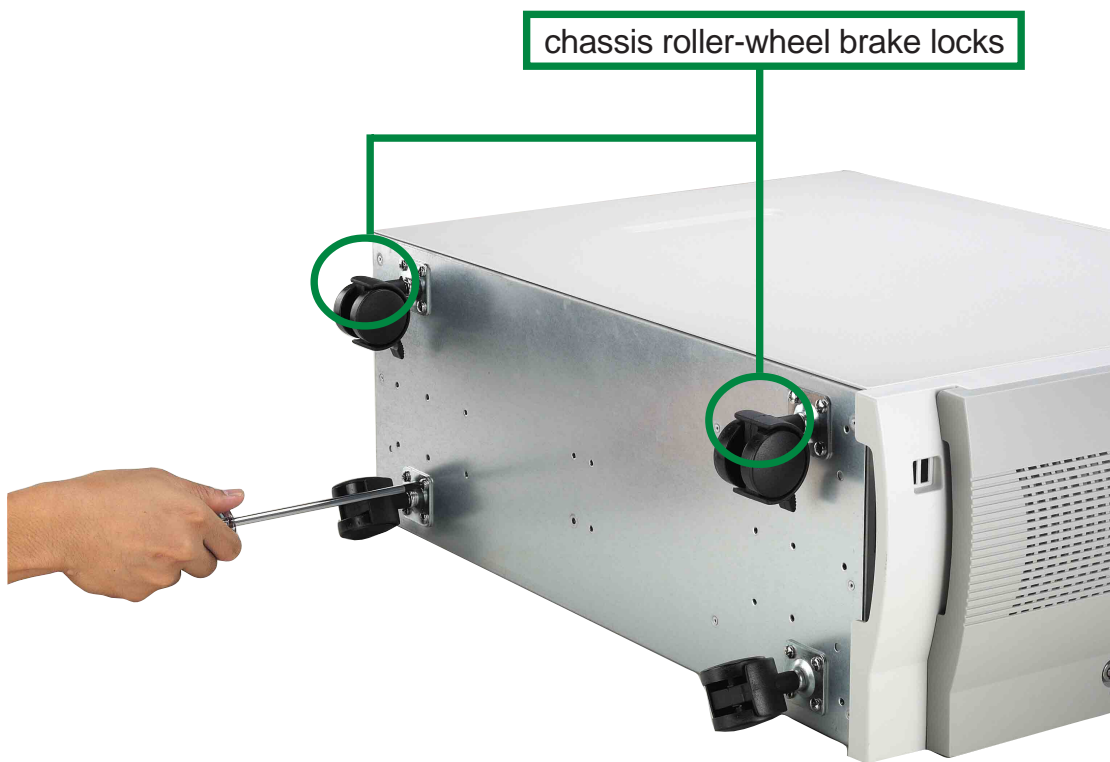

All the chassis roller-wheels can be locked individually with its built-in chassis-roller wheel brake locks.

This appendix contains detailed hardware operation and specifications of the AP1700 redundant power modules.

Redundant Power Modules

The redundant power model has two power supply modules. This hot swap power module can be removed or installed while the server is powered ON. Only one power module is necessary for powering the server, in case two power supply modules are installed, the task of providing power to the server is shared.

To remove the redundant power supply module, follow these steps.

1. Remove the screw.
2. Pull on the handle while pressing down the rubber lever.

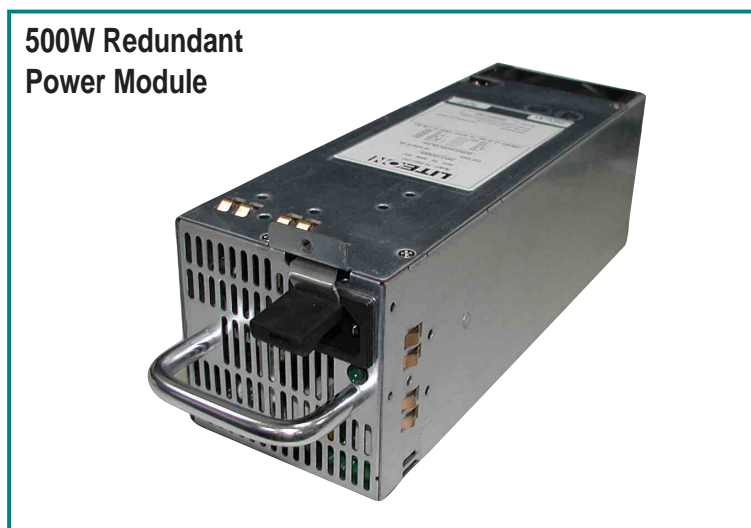
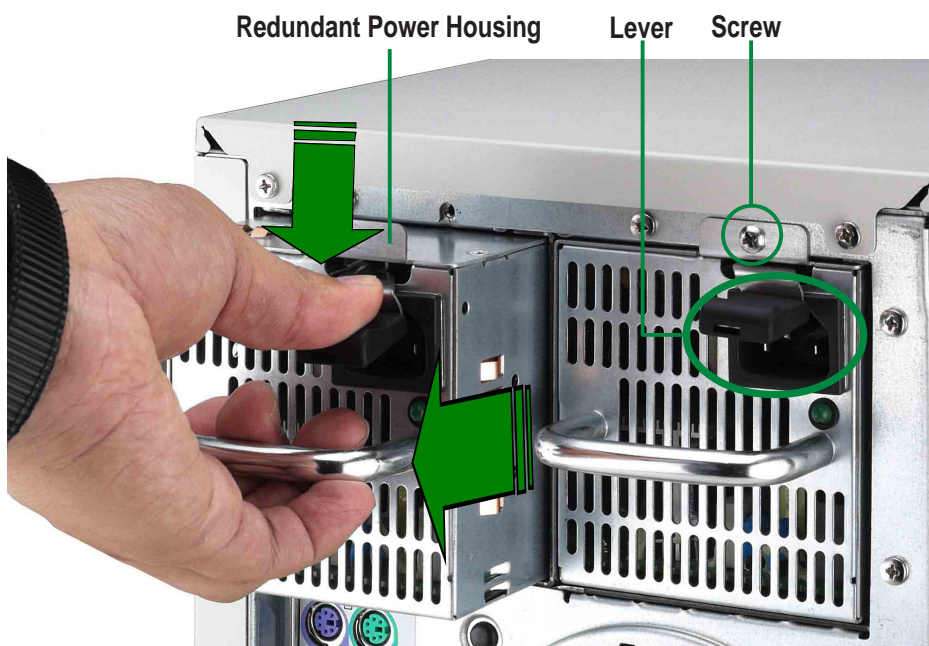

Redundant Power Module Specifications

Output Voltage Regulation

Output Voltage	Min (V)	Nom (V)	Max (V)	Ripple/Noise
+3.33V	3.20	3.33	3.50	50mV _{p-p}
+5V	4.75	5.00	5.25	50mV _{p-p}
+12V	11.4	12.00	12.60	120mV _{p-p}
-12V	-10.8	-12.00	-13.20	120mV _{p-p}
+5VSB	4.75	5.00	5.25	50mV _{p-p}

Output Current Capacity

Output Voltage	Min (A)	Max (A)	Max. Load (W)
+3.33V	1.0	24.5	81.6
+5V	1.0	17.5	87.5
+12V	2.0	25.0	300
-12V	0.0	0.2	2.4
+5VSB	0.1	2.0	10

Over-Voltage Protection (OVP)

Voltage	Min (V)	Max (V)
+3.33V	3.7	4.5
+5V	5.5	6.5
+12V	12.9	14.2

Removing Power Supply case

The redundant power modules are secured in a power supply case that connects to various power supply connectors on the SCSI backplane and the motherboard.

To remove the power supply case, follow these steps:

1. Remove the two (2) top chassis cover screws to release chassis top panel cover.



2. Remove all power cable connections from SCSI backplane, motherboard, floppy and CD-ROM.

3. Remove the six (6) chassis bar screws and release chassis bar.



4. Remove the two (2) right-side chassis cover screws to release right-side cover.



- Remove the four (4) power case side screws.

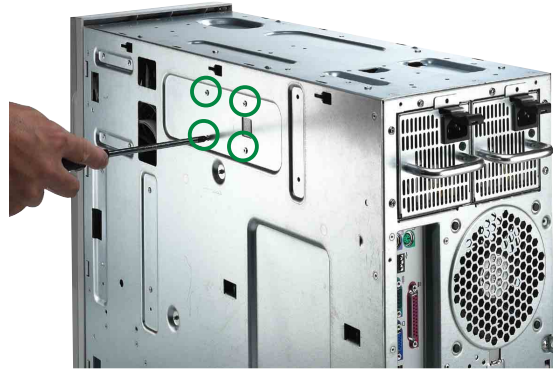

- Remove the six (6) power case top screws.

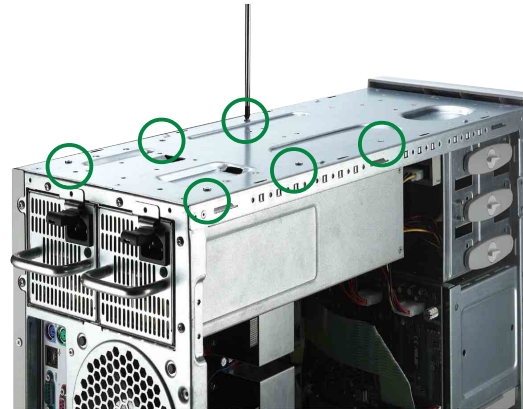

Make sure the power case is well supported or held when releasing the power case screws. The power case may accidentally detach and cause damage to the other components of the server system.

- Slowly pull-out the power case.

Power case rear view

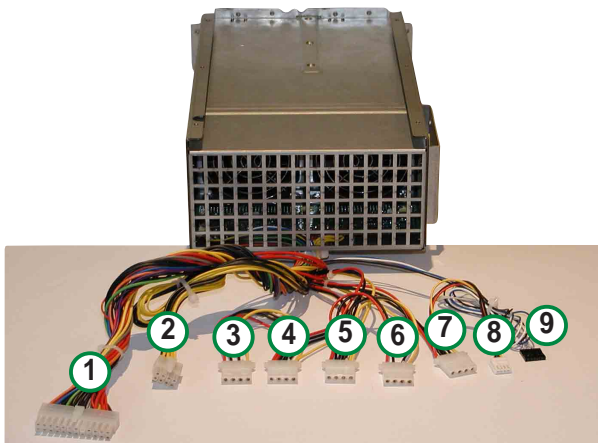

- | | |
|------------------------|---------------------------------|
| 1. 24-pin ATX power | 6. Spare |
| 2. 8-pin AUX 12V power | 7. CD-ROM |
| 3. Spare | 8. Floppy drive |
| 4. SCSI backplane | 9. SMBUS cable for power supply |
| 5. SCSI backplane | |

Power case top view



Power case cable connectors

This appendix lists the common problems that you may encounter while using the AP1700 server system. It lists possible causes of the problems and offers solutions. You may refer to this part and try to solve simple problems before calling customer support.

Troubleshooting



NOTE

Some problems that you may encounter are not due to defects on the system or the components. These problems only requires simple troubleshooting actions that you can perform by yourself.

Problem	Action
The power LED on the server and/or the monitor do not light up	<ol style="list-style-type: none">1. Check the power cable connection on the system rear panel if properly connected.2. Make sure that the power cables are connected to a grounded power outlet.3. Press the power button to make sure that the system is turned on.
The keyboard does not work	Check the keyboard cable if properly connected to the keyboard port.
The mouse does not work	Check the mouse cable if properly connected to the mouse port.
The system does not perform power-on self tests (POST) after it was turned on	<ol style="list-style-type: none">1. Check the memory modules and make sure you installed the correct DIMMs the system supports.2. Make sure that the DIMMs are properly installed on the sockets.

Problem	Action
The system continuously beeps after it was turned on	<ol style="list-style-type: none">1. Check the memory modules and make sure you installed the correct DIMMs the system supports.2. Make sure that the DIMMs are properly installed on the sockets.3. Check if it has VGA output.
The message “Non-system disk or disk error” appears	<ol style="list-style-type: none">1. Check if a bootable HDD is active.2. Check if the HDDs are properly installed and connected to the SCSI connectors on the backplane.
Network connection not available	<ol style="list-style-type: none">1. Make sure the network cable is connected to the RJ-45 port on the rear panel.2. Make sure that you have installed the network drivers from the system support CD.

