

**AP3000**  
**Dual Pentium® II Server Platform**  
**Hardware Reference Guide**

# User's Notice

---

No part of this manual, including the products and software described in it, may be reproduced, transmitted, transcribed, stored in a retrieval system, or translated into any language in any form or by any means, except documentation kept by the purchaser for backup purposes, without the express written permission of ASUSTeK COMPUTER INC. ("ASUS").

ASUS PROVIDES THIS MANUAL "AS IS" WITHOUT WARRANTY OF ANY KIND, EITHER EXPRESS OR IMPLIED, INCLUDING BUT NOT LIMITED TO THE IMPLIED WARRANTIES OR CONDITIONS OF MERCHANTABILITY OR FITNESS FOR A PARTICULAR PURPOSE. IN NO EVENT SHALL ASUS, ITS DIRECTORS, OFFICERS, EMPLOYEES OR AGENTS BE LIABLE FOR ANY INDIRECT, SPECIAL, INCIDENTAL, OR CONSEQUENTIAL DAMAGES (INCLUDING DAMAGES FOR LOSS OF PROFITS, LOSS OF BUSINESS, LOSS OF USE OR DATA, INTERRUPTION OF BUSINESS AND THE LIKE), EVEN IF ASUS HAS BEEN ADVISED OF THE POSSIBILITY OF SUCH DAMAGES ARISING FROM ANY DEFECT OR ERROR IN THIS MANUAL OR PRODUCT.

Product warranty or service will not be extended if: (1) the product is repaired, modified or altered, unless such repair, modification or alteration is authorized in writing by ASUS; or (2) the serial number of the product is defaced or missing.

Products and corporate names appearing in this manual may or may not be registered trademarks or copyrights of their respective companies, and are used only for identification or explanation and to the owners' benefit, without intent to infringe.

- Adobe and Acrobat are registered trademarks of Adobe Systems Incorporated.
- Adaptec, AHA, EZ-SCSI, and AIC is a registered trademark of Adaptec, Inc.
- Sound Blaster, SB16, AWE32, AWE64D and SB-LINK are trademarks of Creative Technology Ltd.
- Intel, LANDesk, and Pentium are registered trademarks of Intel Corporation.
- IBM and OS/2 are registered trademarks of International Business Machines.
- Windows and MS-DOS are registered trademarks of Microsoft Corporation.
- Trend and ChipAwayVirus are trademarks of Trend Micro, Inc.

The product name and revision number are both printed on the product itself. Manual revisions are released for each product design represented by the digit before and after the period of the manual revision number. Manual updates are represented by the third digit in the manual revision number.

For previous or updated manuals, BIOS, drivers, or product release information, contact ASUS at <http://www.asus.com.tw> or through any of the means indicated on the following page.

SPECIFICATIONS AND INFORMATION CONTAINED IN THIS MANUAL ARE FURNISHED FOR INFORMATIONAL USE ONLY, AND ARE SUBJECT TO CHANGE AT ANY TIME WITHOUT NOTICE, AND SHOULD NOT BE CONSTRUED AS A COMMITMENT BY ASUS. ASUS ASSUMES NO RESPONSIBILITY OR LIABILITY FOR ANY ERRORS OR INACCURACIES THAT MAY APPEAR IN THIS MANUAL, INCLUDING THE PRODUCTS AND SOFTWARE DESCRIBED IN IT.

**Copyright © 1999 ASUSTeK COMPUTER INC. All Rights Reserved.**

Product Name:	<b>AP3000</b>
Manual Revision:	<b>1.00 E321</b>
Release Date:	<b>February 1999</b>

# ASUS Contact Information

---

## ASUSTeK COMPUTER INC. (Asia-Pacific)

### *Marketing*

Address: 150 Li-Te Road, Peitou, Taipei, Taiwan 112  
Telephone: +886-2-2894-3447  
Fax: +886-2-2894-3449  
Email: info@asus.com.tw

### *Technical Support*

Tel (English): +886-2-2894-3447 ext. 706  
Tel (Chinese): +886-2-2894-3447 ext. 701  
Fax: +886-2-2895-9254  
Email: tsd@asus.com.tw  
Newsgroup: news2.asus.com.tw  
WWW: www.asus.com.tw  
FTP: ftp.asus.com.tw/pub/ASUS

## ASUS COMPUTER INTERNATIONAL (America)

### *Marketing*

Address: 6737 Mowry Avenue, Mowry Business Center, Building 2  
Newark, CA 94560, USA  
Fax: +1-510-608-4555  
Email: info-usa@asus.com.tw

### *Technical Support*

Fax: +1-510-608-4555  
BBS: +1-510-739-3774  
Email: tsd-usa@asus.com.tw  
WWW: www.asus.com  
FTP: ftp.asus.com.tw/pub/ASUS

## ASUS COMPUTER GmbH (Europe)

### *Marketing*

Address: Harkort Str. 25, 40880 Ratingen, BRD, Germany  
Telephone: 49-2102-445011  
Fax: 49-2102-442066  
Email: sales@asuscom.de

### *Technical Support*

Hotline: 49-2102-499712  
BBS: 49-2102-448690  
Email: tsd@asuscom.de  
WWW: www.asuscom.de  
FTP: ftp.asuscom.de/pub/ASUSCOM

# Contents

---

## **I. Introduction**

1-1. How this Manual is Organized .....	7
Symbols .....	7
1-2. Component Checklist .....	8
1-3. Features .....	9
1-4. Safeguards .....	10
1-5. Electrical Safety .....	11

## **II. Components**

2-1. Server Front Side .....	13
2-2. Server Back Side .....	14
2-3. Server Left Side .....	15

## **III. Basic Operation**

3-1. Starting the Server .....	16
3-2. LEDs .....	16
3-3. BIOS Setup .....	16

## **IV. Hardware Setup**

4-1. Opening the Chassis .....	17
Panel Screws .....	17
Removing the Right Panel .....	17
Opening the Left Panel .....	18
Chassis Circulation System .....	18
Fan Modules .....	18
4-2. Rear Cooling Fan Control Board .....	19
Rear Cooling Fan Control Board Settings .....	19
4-3. Motherboard .....	20
Motherboard Spacers .....	20
Install the Baseboard .....	20
Motherboard Screws .....	20
Device Cables .....	21
Cable Connections .....	21
4-4. Central Processing Unit (CPU) .....	22
Install Retention Mechanisms .....	22
Install Retention Mechanism Brace Bars .....	22
Install Cartridge Lifters .....	23
Install Retention Mechanism Cap .....	23
Install Retention Mechanism Frame .....	23
4-5. Chassis Intrusion Switch .....	24
Chassis Intrusion Connector .....	25
4-6. Expansion Cards .....	25
4-7. Fixed Storage Devices .....	26

# Contents

---

Floppy Drive and CD-ROM .....	26
Fixed Storage Device Tray .....	26
Fixed Device Bay Cover Clips .....	27
Fixed Device Bay Cover .....	27
Storage Device Spacers .....	27
4-8. Five-Tray Hot-Swap Bay .....	28
4-9. Three-Tray Hot-Swap Bay .....	28
Hot-Swap Tray .....	29
Hot-Swap Bay .....	29
4-10. Front Cooling Fans .....	30
Front Cooling Fan Control Board .....	31
Hard Disk Drive Message Board.....	31
4-11. SCSI Backplane .....	32
4-12. SCSI ID Setting .....	33
SCSI ID Dip Switches .....	33
4-13. Expansion Card Guide .....	34
Securing Expansion Card Guide.....	34
4-14. SCSI Termination .....	35
4-15. Power Supply .....	35
Power Supply Mounting .....	35
Power Supply Information .....	36
4-16. Power Supply Requirement .....	37
Power Supply Requirement Calculation Table .....	37
<b>V. Appendix</b>	
i. Electrical SafetySCSI Cable Limits .....	39
ii. Glossary .....	40

# FCC & DOC COMPLIANCE

---

## ***Federal Communications Commission Statement***

This device complies with FCC Rules Part 15. Operation is subject to the following two conditions:

- This device may not cause harmful interference, and
- This device must accept any interference received, including interference that may cause undesired operation.

This equipment has been tested and found to comply with the limits for a Class B digital device, pursuant to Part 15 of the FCC Rules. These limits are designed to provide reasonable protection against harmful interference in a residential installation. This equipment generates, uses and can radiate radio frequency energy and, if not installed and used in accordance with manufacturer's instructions, may cause harmful interference to radio communications. However, there is no guarantee that interference will not occur in a particular installation. If this equipment does cause harmful interference to radio or television reception, which can be determined by turning the equipment off and on, the user is encouraged to try to correct the interference by one or more of the following measures:

- Re-orient or relocate the receiving antenna.
- Increase the separation between the equipment and receiver.
- Connect the equipment to an outlet on a circuit different from that to which the receiver is connected.
- Consult the dealer or an experienced radio/TV technician for help.

**WARNING!** The use of shielded cables for connection of the monitor to the graphics card is required to assure compliance with FCC regulations. Changes or modifications to this unit not expressly approved by the party responsible for compliance could void the user's authority to operate this equipment.

## ***Canadian Department of Communications Statement***

This digital apparatus does not exceed the Class B limits for radio noise emissions from digital apparatus set out in the Radio Interference Regulations of the Canadian Department of Communications.

# I. Introduction

---

You are reading the AP3000 Hardware Reference Guide. This hardware reference guide provides information and procedures on the various components used in this server. Some components shown in this reference guide are optional and may be individually purchased to complete the server. This guide is intended for experienced users and integrators with hardware knowledge of personal computers. You should also read all documentation and manuals included with this server and with your separately purchased components.

## • 1-1. How this Manual is Organized

---

There are only a few sections in this reference guide as follows:

### **I. Introduction**

This section gives general and startup information and features for this server.

### **II. Components**

This is the main section which gives descriptions of each server component.

### **III. Getting Started**

This section gives information on getting started with the server.

### **IV. Hardware Setup**

This section gives information on setting up the server.

### **V. Appendix**

This section gives you additional information to help plan your server.

## Symbols

To complete certain tasks safely and completely, you should be aware of a few symbols used throughout this guide.

 **WARNING:** Information to prevent injury to yourself when trying to complete a task.

 **CAUTION:** Information to prevent damage to the components when trying to complete a task.

 **IMPORTANT:** Information that **MUST** be followed in order to complete a task.

 **NOTE:** Tips and information to aid in completing a task.

 **PHILIP (CROSS) SCREW DRIVER:** Tools required to install or remove the components in this server.

 **STANDARD (FLAT) SCREW DRIVER:** Tools required to install or remove the components in this server.

 **STEP:** Actions to complete a task.

# I. Introduction

---

## • 1-2. Component Checklist

---

If assembling this server by yourself, it is important to prepare all the server components before starting. This will save a great deal of time by not having to hunt down components. The following checklist provides a guideline as to the necessary components for a server.

### Standard components

- Motherboard: XG-DLS
- Chassis: AS-30
- Power Supply: ATX
- Processor (CPU): Pentium® II Xeon™
- Memory Modules: 8, 16, 32, 64, 128, 256, 512MB SDRAM
- Hard Drive: Ultra2, Ultra-wide
- Floppy Drive: 1.44MB
- CD-ROM Drive: 40X
- Expansion Cards: Ethernet, Graphics, Modem
- SCSI Terminator: Passive terminator for 68pin SCSI cables
- User's Manuals: CD-ROM, SCSI, Motherboard, Hardware Guide

### Optional components

- Ethernet Card: (optional PCI-L101)
- RAID Controller: (optional PCI-DA2100, PCI-DA2200, DA-3000 RAID Controller)
- Expansion Card Stabilizer



# I. Introduction

## • 1-3. Features

AP3000 is a department server configured on the XG-DLS smart motherboard which uses the 440GX chipset from Intel and supports two Pentium II processors and 100MHz front side bus in order to handle even the most complicated server tasks. The following are highlights to this server's many features. For additional features and details, read the motherboard User's Manual included with this server package.

- **Processor:** Supports dual Intel® Pentium® II Xeon™ processors from 450MHz to 550MHz on each processor for extreme server processing speeds.
- **Memory:** Equipped with four DIMM sockets to support up to 2GB SDRAM with ECC.
- **AGP Slot:** Supports Accelerated Graphics Port cards for high performance, component level interconnect targeted at 3D graphical display applications. Using AGP will also free up a PCI slot.
- **Adaptec SCSI Chipset:** Features Adaptec AIC-7896 dual-channel Ultra2 SCSI chipset that supports any combination of 50-pin narrow or 68-pin wide/ultra2 devices through the onboard 50-pin and 68-pin SCSI connectors.
- **Device Bays:** Support one floppy, one CD-ROM, two additional fixed devices, and five hot-swap SCA hard disk drives.
- **SCSI Backplane:** Ultra2 SCSI SCA backplane with remote SCSI ID dip switches and power to support up to 5 Ultra2 SCSI SCA hard drives.
- **Onboard IDE:** Up to 33MB/sec IDE transfer with UltraDMA/33.
- **Onboard Hardware Monitor:** Provides information for system and processor voltages, fan status, temperature, chassis intrusion, and provides automatic system restart.
- **Onboard LAN:** Onboard Intel 10/100Base-TX Fast Ethernet.
- **ASMA and Intel LDSM:** Provides server monitoring, management, and control.
- **RAID Controller:** Supports PCI-DA2100A(UW) RAID controller, PCI-DA2200(U2) or DA-3000(U2) SCSI to SCSI RAID controller, which provides good fault tolerance.

# I. Introduction

## • 1-4. Safeguards

Observe the following safety instructions any time you are connecting or disconnecting any devices.

### Operation Safety



#### **IMPORTANT**

- Any operation on this server must be conducted by certified or experienced engineers.
- Before operating your server, carefully read all the manuals included with the server package.
- Before using the server, make sure all cables are correctly connected and the power cables are not damaged. If any damage is detected, contact your dealer as soon as possible.
- To avoid short circuits, keep paper clips, screws, and staples away from connectors, slots, sockets and circuitry.
- Before opening the chassis panels, make sure all power cables are unplugged.
- Avoid dust, humidity, and temperature extremes. Place the server on a stable surface.
- If the power supply is broken, do not try to fix it by yourself. Contact an authorized dealer.
- It is recommended that you wear gloves when assembling or disassembling the server to protect from cuts and scrapes.
- When the server is powered on, heat sinks and the surfaces of certain IC devices may be hot. Do not touch them. Check whether the fans are functioning properly.

### Tools Required

A Phillips (cross) screwdriver and a standard (flat) screwdriver are needed to install or remove the components in this server.

# I. Introduction

## • 1-5. Electrical Safety

### IMPORTANT

- Before installing or removing signal cables, ensure that the power cables for the system unit and all attached devices are unplugged.
- To prevent electrical shock hazard, disconnect the power cable from the electrical outlet before relocating the system.
- When adding or removing any additional devices to or from the system, ensure that the power cables for those devices are unplugged before the signal cables are connected. If possible, disconnect all power cables from the existing system before you add a device.
- Use one hand, when possible, to connect or disconnect signal cables to prevent a possible shock from touching two surfaces with different electrical potentials.



### CAUTION

This product is equipped with a three-wire power cable and plug for the user's safety. Use the power cable in conjunction with a properly grounded electrical outlet to avoid electrical shock.

### IMPORTANT

Motherboards, adapters, and disk drives are sensitive to static electricity discharge. These devices are wrapped in antistatic bags to prevent this damage. Take the following precautions:

- If you have an antistatic wrist strap available, use it while handling the device.
- Do not remove the device from the antistatic bag until you are ready to install the device in the system unit.
- With the device still in its antistatic bag, touch it to a metal frame of the system.
- Grasp cards and boards by the edges. Hold drives by the frame. Avoid touching the solder joints or pins.
- If you need to lay the device down while it is out of the antistatic bag, lay it on the antistatic bag. Before picking it up again, touch the antistatic bag and the metal frame of the system unit at the same time.
- Handle the devices carefully in order to prevent permanent damage.

---

(This page was intentionally left blank)

## II. System Components

### • 2-1. Server Front Side

The front side of the server is provided to show the front exterior components of this server. The chassis is made of strong rust-resistant metal and covered with a protective ivory surfacing.

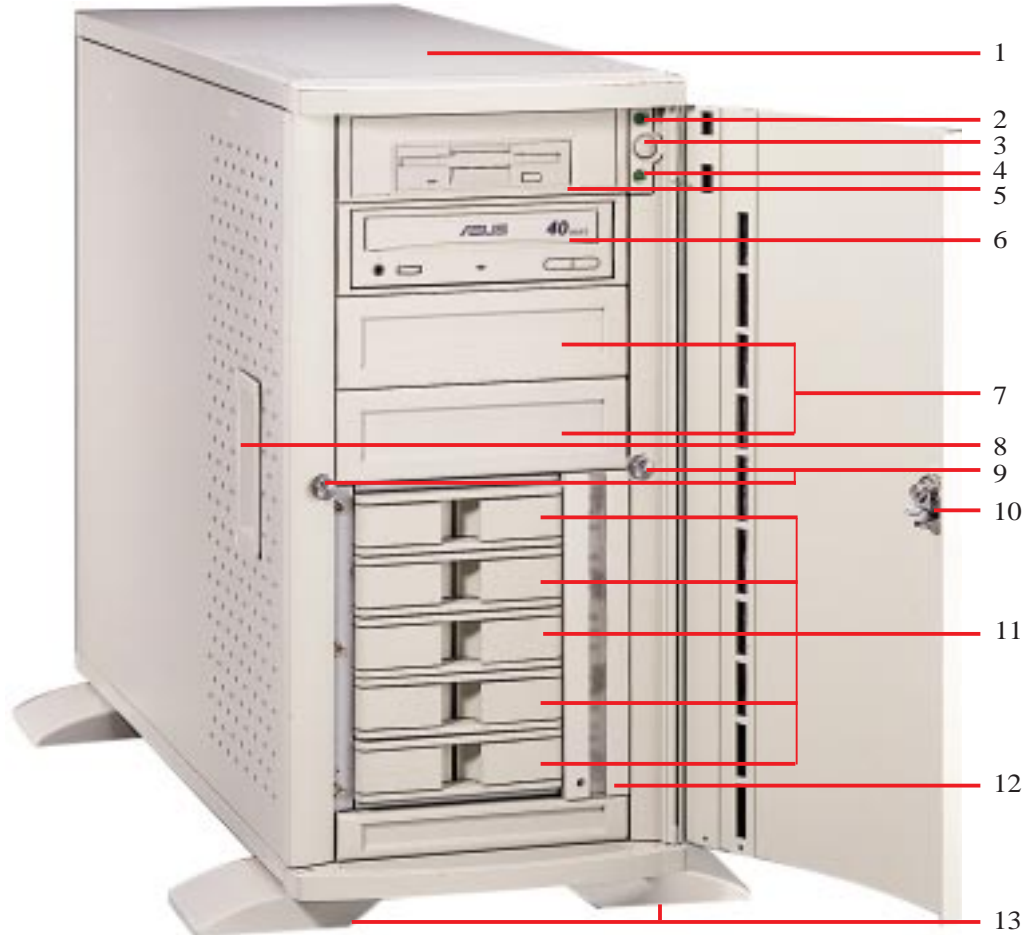

II. Components  
Front Side

1. Top Panel
2. Power LED
3. ATX Power Button
4. Hard Drive Access LED
5. Floppy Disk Drive
6. CD-ROM Drive
7. Drive Expansion Bay
8. Side Panel Handle
9. Side Panel Screw
10. Metal Door Lock
11. Hot Swap Tray
12. Hard Drive Fan Module
13. Chassis Stabilizers

Server Front Side

## II. System Components

### • 2-2. Server Back Side

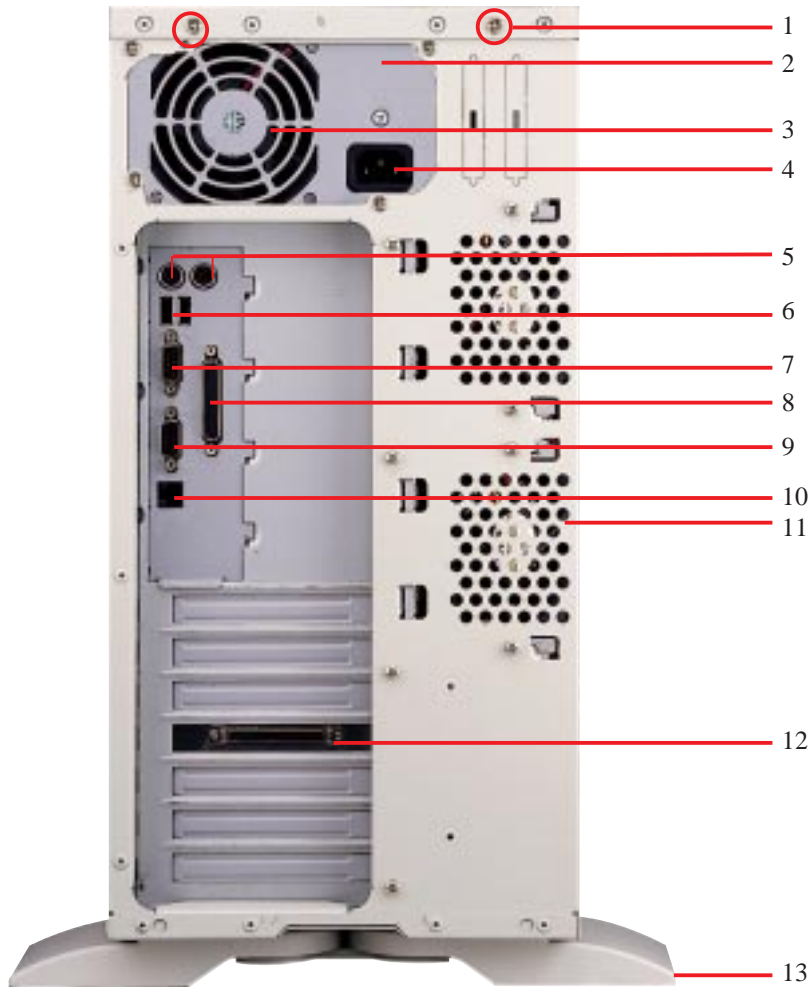

II. Components  
Back Side

1. Top Panel Screw
2. Power Supply
3. Power Supply Fan
4. AC Power In Connector
5. PS/2 Keyboard, PS/2 Mouse
6. USB Ports 1 and 2
7. Serial Port COM1
8. Parallel Port
9. Serial Port COM2
10. RJ45 Port (LAN)
11. Rear Fan Module
12. RAID Controller (Optional)
13. Chassis Stabilizer

Server Back Side

## II. System Components

### • 2-3. Server Left Side

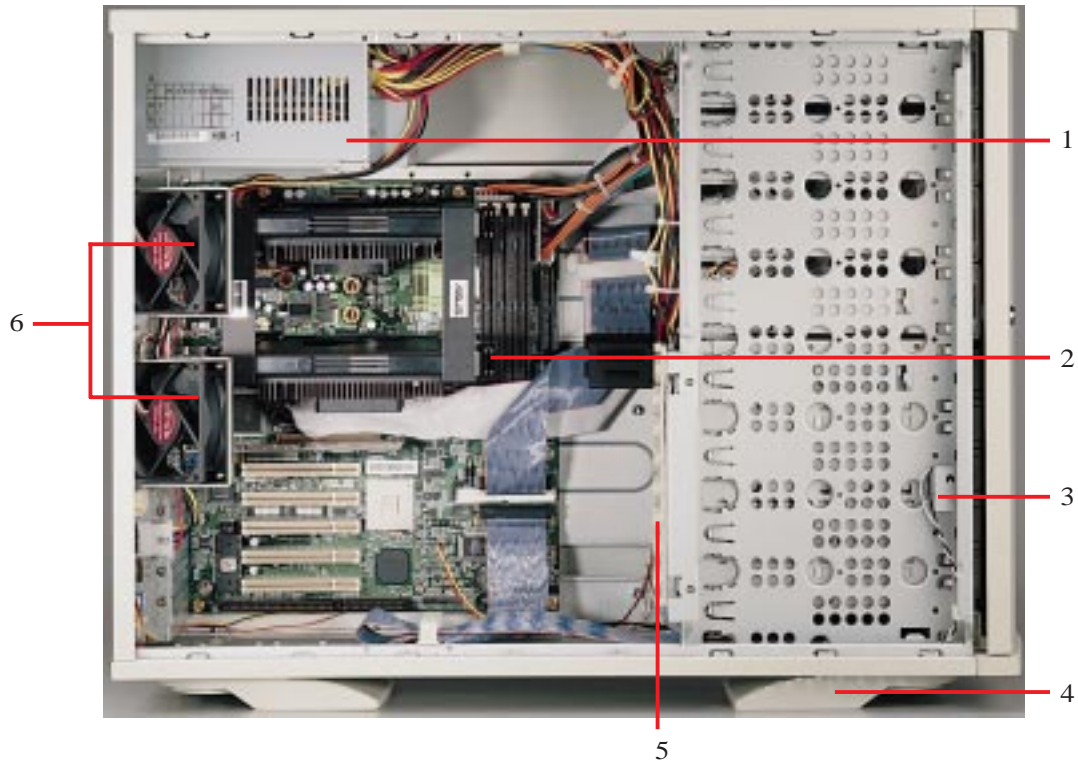

II. Components  
Left Side

1. Power Supply
2. Motherboard
3. Chassis Intrusion Switch
4. Chassis Stabilizer (shown recessed)
5. Expansion Card Guide
6. Rear Fans

Server Left Side

# III. Basic Operation

## • 3-1. Starting the Server

Turn ON the server by pushing the power button. The power button will snap back when released because ATX power systems have an electrical ON/OFF switch unlike AT systems which require a permanent ON or OFF position. If the Power On LED does not light, make sure the power cord is connected to the system unit and to a working grounded outlet.



### IMPORTANT

The power switch only turns off DC power (power supply output). To turn off AC power (power supply input), you need to unplug the electrical cord from the outlet.

## • 3-2. LEDs

There are two LEDs on the top left-hand corner of the front panel. The upper one is the power LED and the lower one is the hard drive access LED. When the system is booted, the power LED is green. When the hard drive is being accessed, the hard drive access LED is green.

LEDs

Power LED

Power Switch

Hard Drive  
Access LED



## • 3-3. BIOS Setup

This server does not come with any pre-installed software. When booting your server for the first time, make BIOS settings by following the motherboard User's Manual.



### NOTE

When installing Windows NT 4.0, use the Windows NT installation disks. Installing from the CD will require you to pre-install SCSI drivers by pressing F6 before setup begins. You may need device drivers on a floppy disk in order to install devices during the Windows NT 4.0 setup. To use the onboard SCSI, you will need to copy Adaptec's SCSI driver (from the provided support CD) onto a floppy disk ("Winnt", "Disk1", "Txtsetup.oem").



# IV. Hardware Setup

This section gives descriptions of how to install and remove components. When setting up devices on the server, perform the following steps.

- 4-1. Opening the Chassis



## Panel Screws

The top panel on the chassis is secured by two screws on the back of the server. To open the top panel, remove the screws with a screw driver.



**NOTE:** You do not have to open the top panel before removing the left panel.

The side panels are secured by two large thumb screws on the front of the server, which can be turned with your fingers.



## Removing the Right Panel

To remove the right panel, the front door must be removed by pushing down on the hinge spring.



# IV. Hardware Setup



Pulling the panel forward



## Opening the Left Panel

There are two identical side panels on the chassis, one on each side. To open the left side of the panel (see the left view), remove the side panel screw, then pull the handle outward while pulling the panel forward. To open the right panel, the front door must be removed first.



Latches



## Chassis Circulation System

The chassis air circulation system is comprised of two 3 inch (8 cm) fans. The fan modules are held by two screws and four latches on the inside rear of the chassis. To take out the fans, remove the screws.

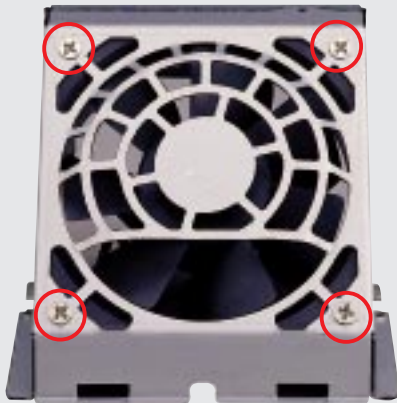

## Fan Modules

There are four screws used to secure the fan into the individual frames. To replace the fan, remove the screws.



**IMPORTANT:** Usually, the rotation of the fan sends air toward the manufacturer's label on the center of the fan.

# IV. Hardware Setup

## • 4-2. Rear Cooling Fan Control Board

The rear fans are controlled and monitored by a control board. The fan control board requires power input from the power supply which allows the individual fans to obtain their power when connected to the control board. The control board also sends fan status information to the LEDs located on the front of the server and to the ASMA software. The fan control board's cable connections are shown below.

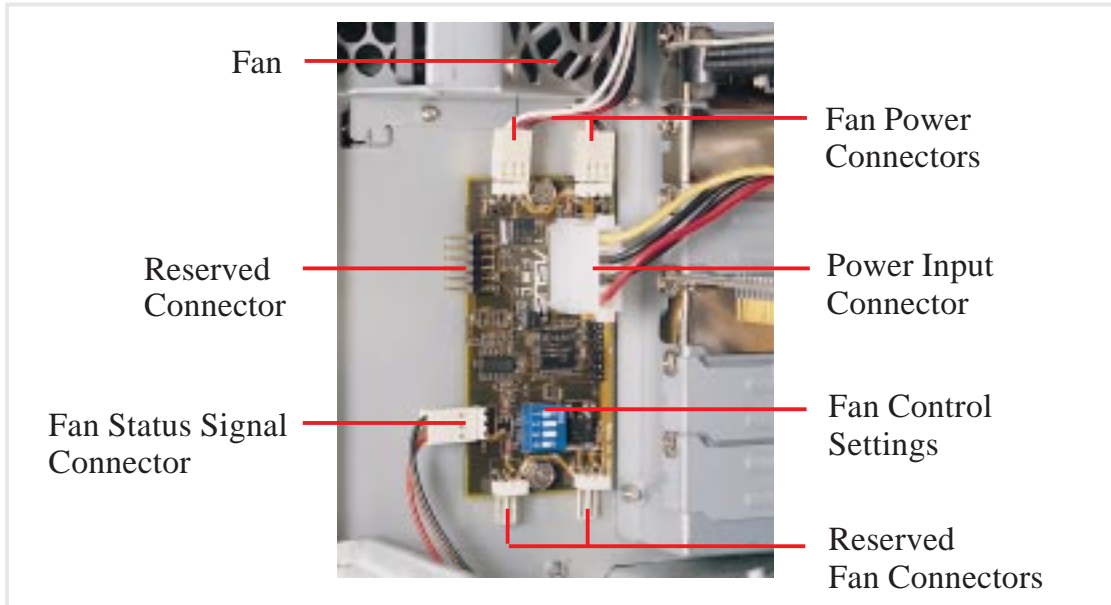

### Rear Cooling Fan Control Board Settings

The rear fan control board has DIP switches to allow controlling the control board status and the number of fans.

DIP Switch SET1	Fan Control Board Setting
ON (momentarily)	Reset Control Board
OFF	Normal (Default)

SET2	SET3	SET4	Number of Fans
ON	ON	ON	1
ON	ON	OFF	2 (Default)
ON	OFF	ON	3
ON	OFF	OFF	4
OFF	ON	ON	5
OFF	ON	OFF	6
OFF	OFF	ON	7
OFF	OFF	OFF	8

# IV. Hardware Setup

## • 4-3. Motherboard

You can remove the extended expansion card guide before installing or removing the motherboard. All screws are necessary to provide the needed stabilization to support all the motherboard expansion cards used in this chassis.

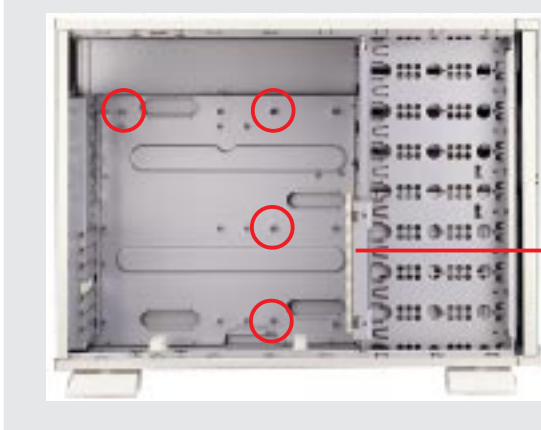

### Motherboard Spacers

Place four spacers in the areas circled on the chassis.

Extended Expansion Card Guide



Spacer



Place and tighten three captive nuts in the corner locations circled.



### Install the Baseboard

A metal baseboard is required to add stability to the motherboard. A rubber pad is placed between the metal board and motherboard to provide insulation to prevent shorting. Align the rubber pad over the metal baseboard so that the holes match. Align the XG-DLS motherboard over the rubber pad and metal baseboard so that the screws match up with the motherboard's screw holes.

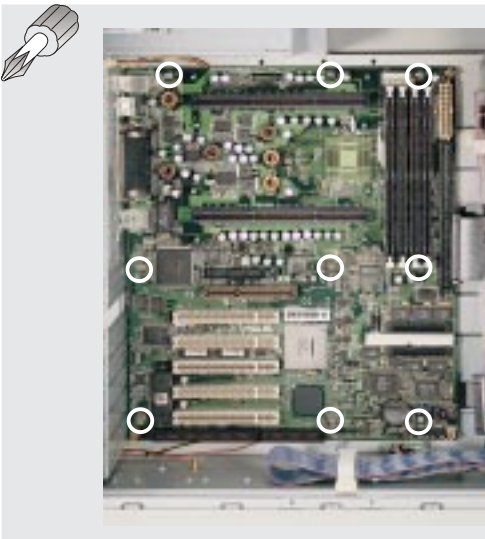

### Motherboard Screws

Place nine screws in the areas circled on the motherboard. The four screws used with the motherboard spacers are longer than the others. (See page 22 for samples.) Be careful not to over-tighten the screws. Doing so may damage your motherboard.

# IV. Hardware Setup

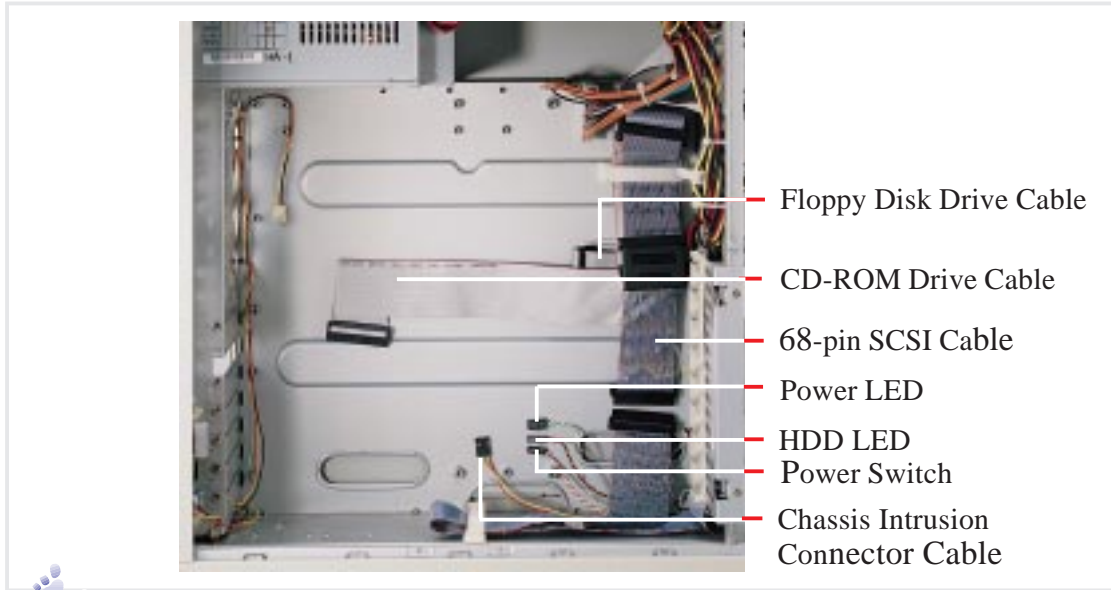

## Device Cables

Several cables are used for connecting devices in this chassis. The following picture points out the name of each cable and its suggested location. Plastic keepers protect the cables from contacting with the fans and other devices. Make sure that all cables are properly secured.

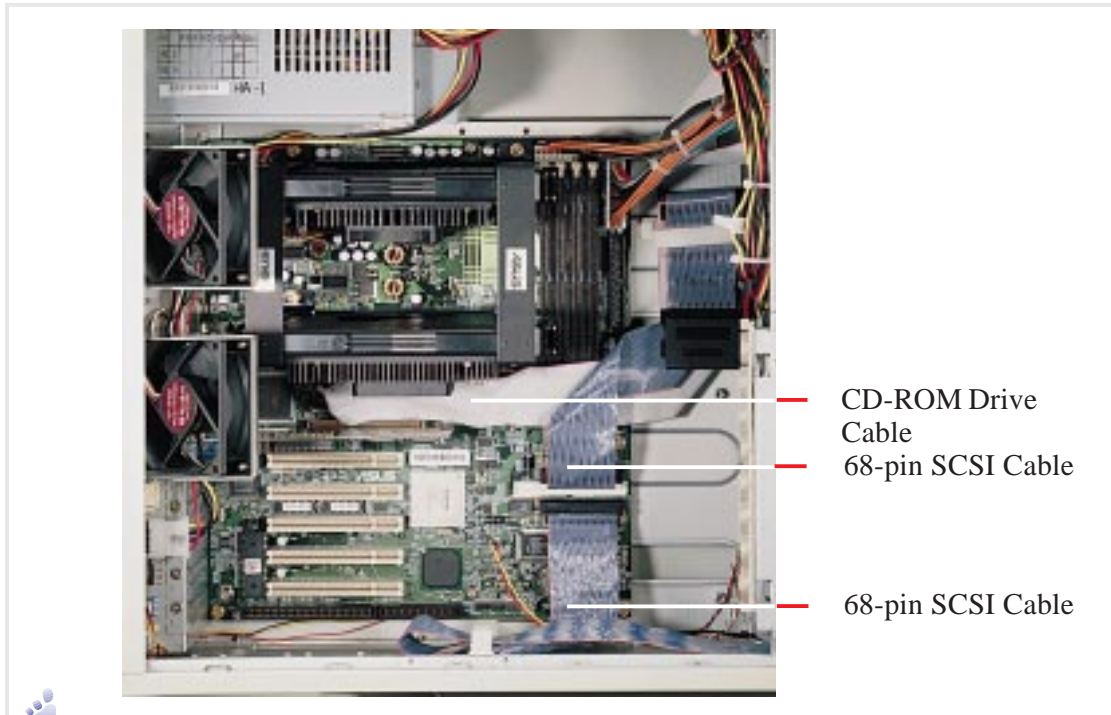

## Cable Connections

The cables connect to the motherboard as shown. The motherboard includes onboard SCSI with 68-pin and 50-pin SCSI connectors. RAID connections require a RAID card.

# IV. Hardware Setup

## • 4-4. Central Processing Unit (CPU)

The motherboard has two connectors for processor retention modules. One retention module can have one Xeon processor installed. Before installing the CPU, secure the motherboard on the rubber pad and metal baseboard. (See p. 20.)

When only one processor is used, the other Slot 2 connector must be terminated with the provided front side bus termination module.

For memory installation, refer to the motherboard User's Manual.

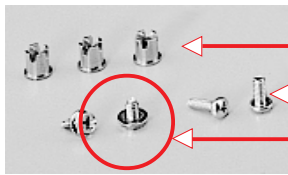

Captive Nut

Long Screw (aligned with spacers)

Short Screw

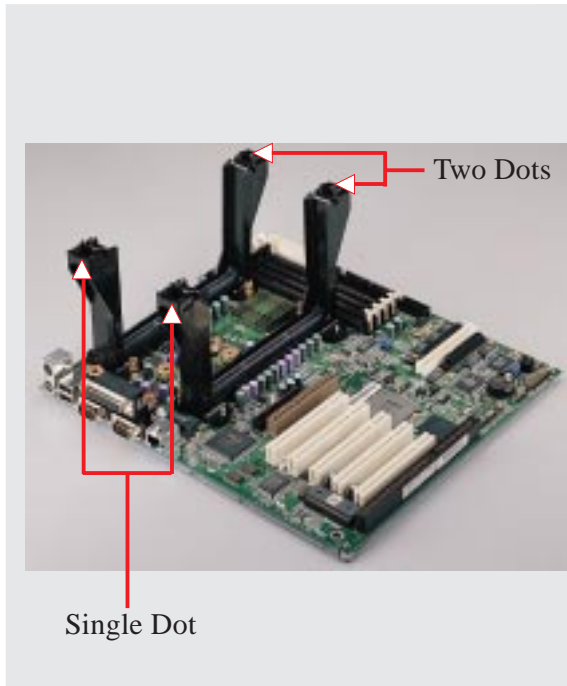

Two Dots

Single Dot



### Install Retention Mechanisms

For the retention mechanism, there is a left and a right side. The left side has a single dot and the right side has two dots (when holding the motherboard with the ATX connectors to the left). Place the retention mechanisms' holes over the screws and the Slot2. Screw four captive nuts onto the screws as circled in the picture on the right. Do not place the other captive nuts yet.



### Install Retention Mechanism Brace Bars

Place the retention mechanism brace bar into the groove on the top of the retention mechanism as shown.



Retention Mechanism Brace Bar

# IV. Hardware Setup

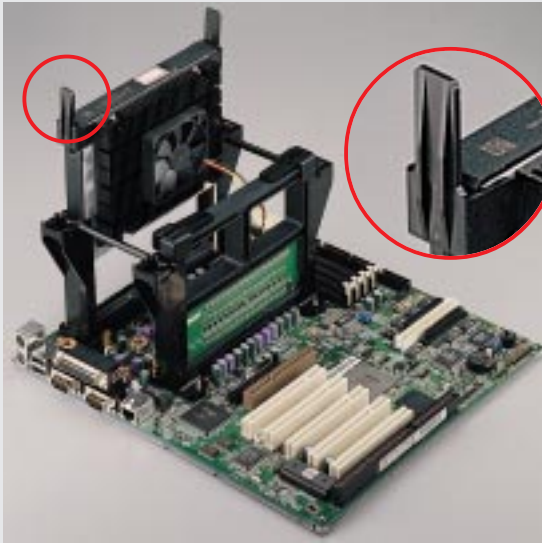

## Install Cartridge Lifters

Each Xeon processor requires two lifters in order to allow safe removal of the processor. The lifters clamp on to the cartridge on the two holes at the top of each corner.

For the lock bar, there is a left and a right side. The left side has a single dot and the right side has two dots (when holding the motherboard with the ATX connectors to the left).

Single Dot

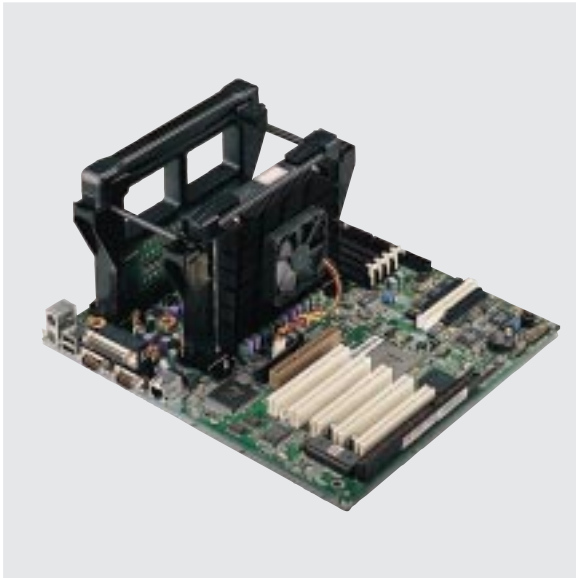
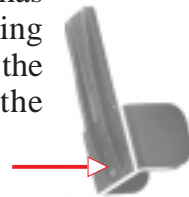

## Install Retention Mechanism Cap

The cap must go in from the left side first (with the ATX connectors to the left). The left side has one dot, while the right side has two dots. The right end of the cap enters the retention mechanism and a click is heard as it snaps in place.

Two Dots

Single Dot

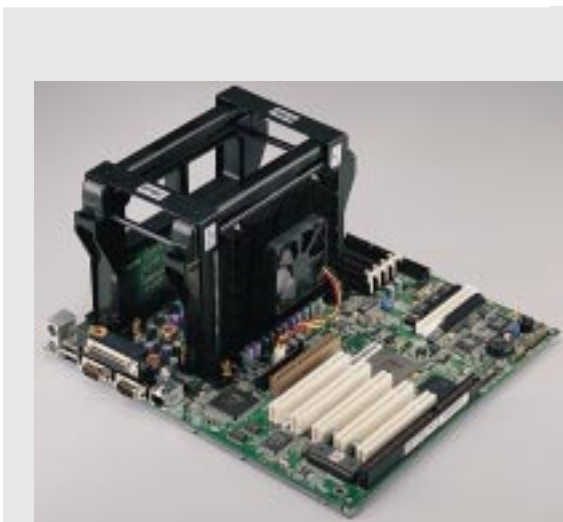

## Install Retention Mechanism Frame

A metal frame is used across both retention mechanisms. After installing the frame, four captive nuts should be tightened on the feet of the frame to the screws protruding from the retention mechanisms.

Sticker (facing the CPU fan)



# IV. Hardware Setup

## • 4-5. Chassis Intrusion Switch

The chassis provides a micro toggle switch that must be connected to the motherboard for the chassis intrusion detection to work. The motherboard will signal the ASMA software when the side panel is opened. The connection diagram is given here.

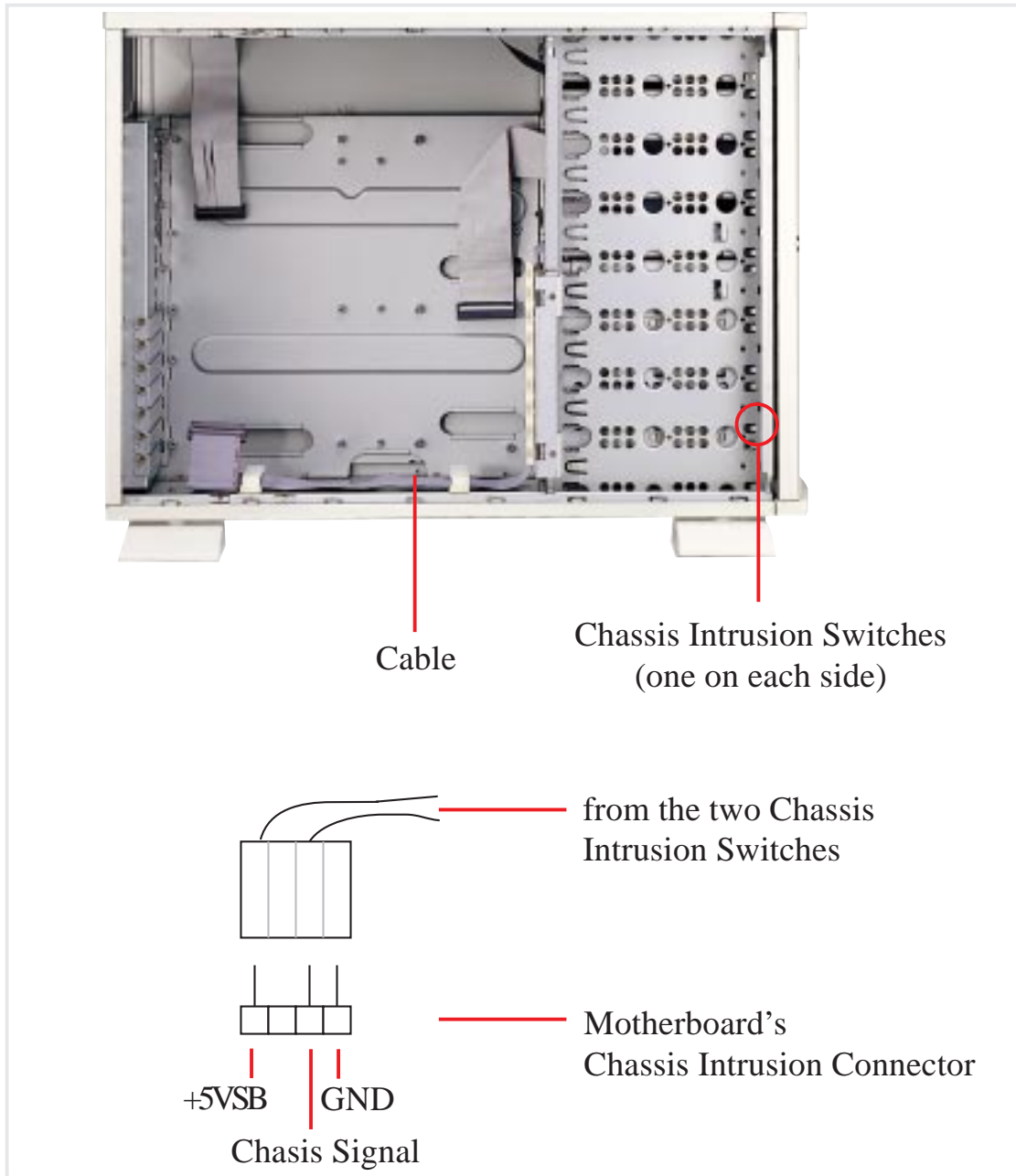

IV. Hardware Setup  
Chassis Intrusion Switch



### IMPORTANT

To prevent misconnection, one pin is removed from the motherboard's chassis intrusion connector.



# IV. Hardware Setup



Chassis Intrusion Connector



## Chassis Intrusion Connector

The two chassis intrusion switches are connected to the motherboard's chassis intrusion connector through a single connector.

### • 4-6. Expansion Cards



Expansion cards can be easily installed just like on any standard PC. Up to 5 PCI or 1 ISA cards can be installed. One AGP slot is also available for an AGP graphics adapter to provide hardware 3D acceleration and free up an extra PCI slot.

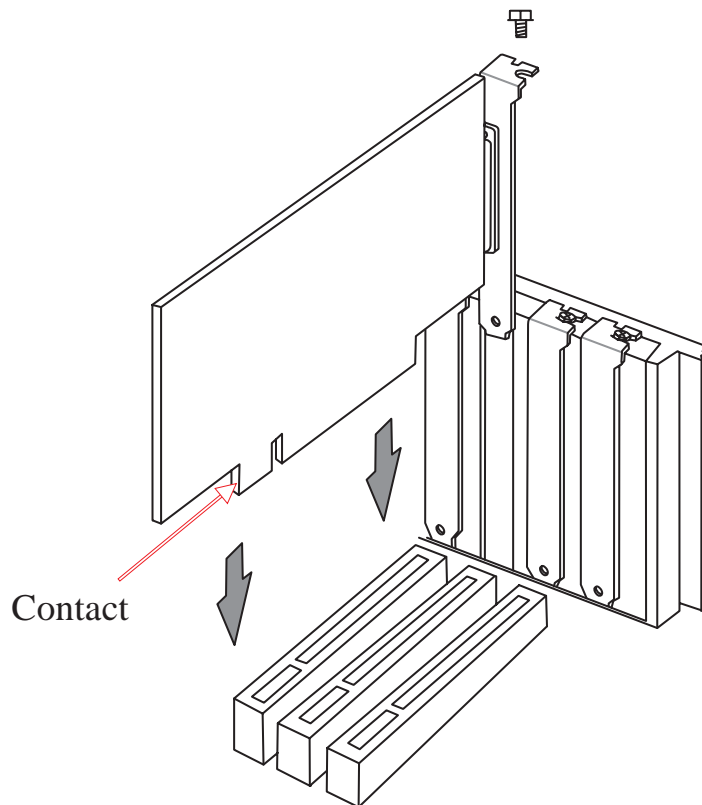

#### CAUTION

Make sure that the total amperage of your installed expansion cards does not exceed the system power specification.

# IV. Hardware Setup

## • 4-7. Fixed Storage Devices

Internal fixed storage devices are mounted on removable trays. There are four available, one for a floppy device and another three for full-size devices.



### Floppy Drive and CD-ROM

The floppy drive fits in the top-most bay along with the power button. A CD-ROM can fit into either the second, third, or fourth bay from the top. A metal clip on each side of the device tray secures the tray in place. Press inward to release the clips. The tray slides in or out on the side rails.

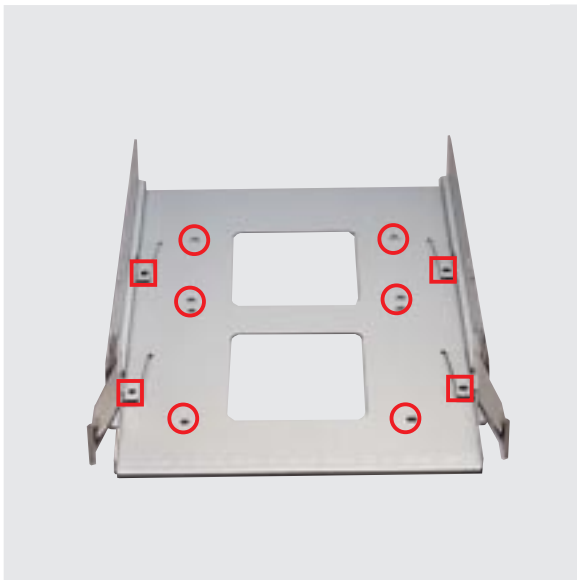

### Fixed Storage Device Tray

There are six screws provided (as circled) for mounting a 4 inch device such as a floppy or hard disk drive. Four screws are provided (as boxed) for mounting a 6 inch device such as a CD-ROM or tape drive.

# IV. Hardware Setup



## Fixed Device Bay Cover Clips

The device bay panel is held by two plastic clips on each side. Press these clips in with a screwdriver to release.



## Fixed Device Bay Cover

After releasing the device bay cover clips, pry the cover away from the chassis using a screw driver from the front.



## Storage Device Spacers

A floppy drive spacer is used to cover the floppy drive and power button. A standard storage device spacer is used to cover the CD-ROM, tape drive, or additional CD-ROMs. You should purchase an extra spacer for each storage device.

Floppy Drive Spacer

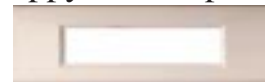

Fixed Device Spacer



# IV. Hardware Setup

## • 4-8. Five-Tray Hot-Swap Bay

Maximum uptime in a server requires devices that can be easily replaced or “swapped.” The main hard drives are mounted in internal hot-swap trays for easy replacement. The AP3000 hot-swap bay has two different models: Five-tray hot-swap bay and three-tray hot-swap bay. The 1.0 inch SCA hot-swap bay can accommodate five 1.0 inch hard disk drives.

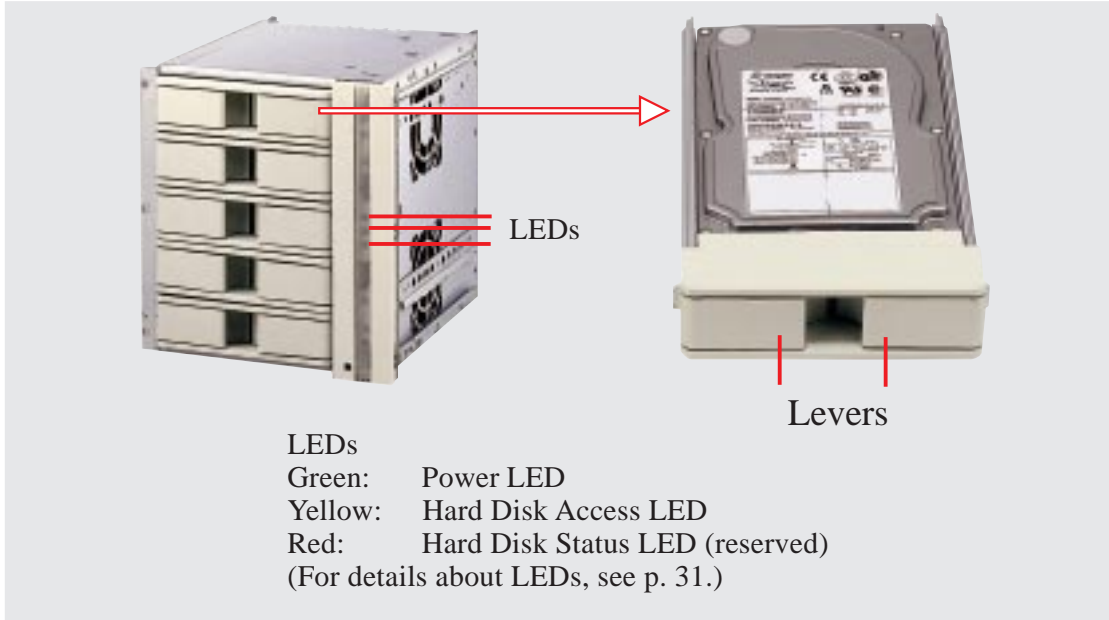

## • 4-9. Three-Tray Hot-Swap Bay

The 1.6 inch SCA hot-swap bay can accommodate three 1.6 or 1.0 inch hard disk drives.

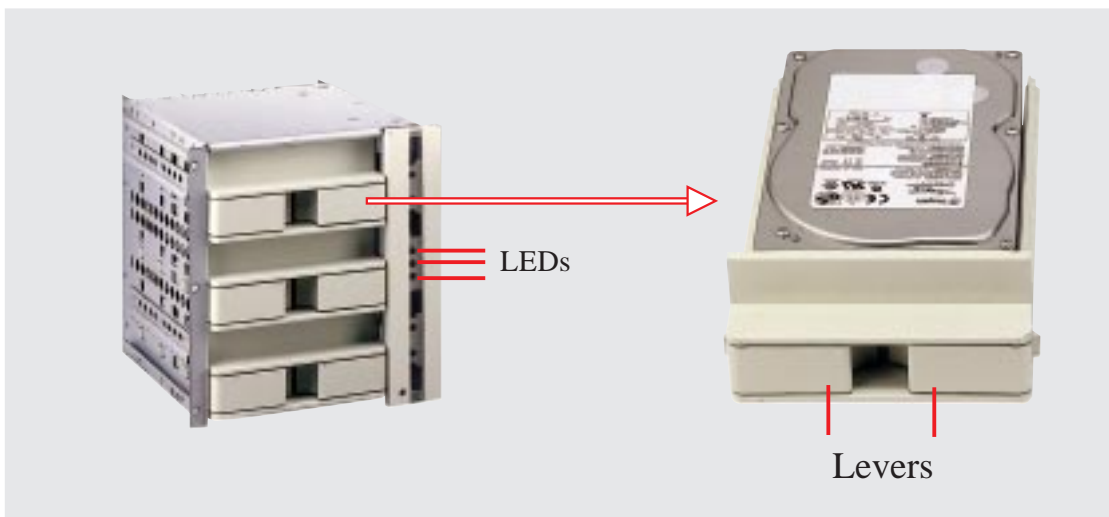

### IMPORTANT



Each SCA hot-swap bay provides an aluminum carrier only for a single SCSI hard disk drive.

## IV. Hardware Setup

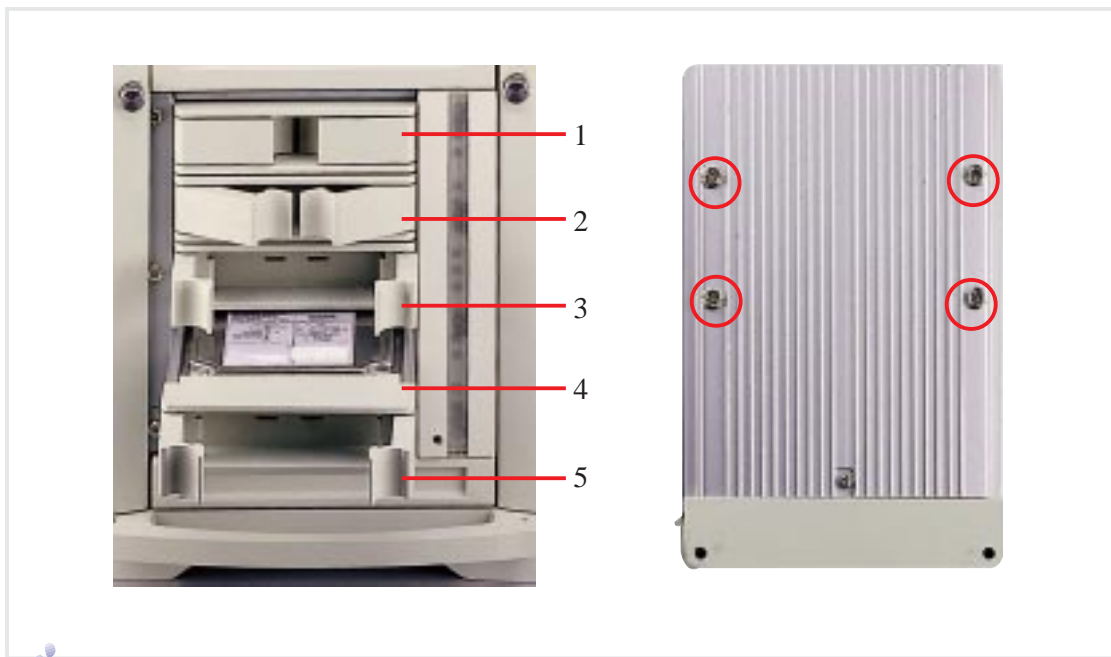

### Hot-Swap Tray

There are two levers on the front of the hot-swap tray to help release or lock the tray. To remove the tray, extend both levers and pull on both levers. To install the tray, push the tray firmly into the bay with the levers extended, then close the levers.

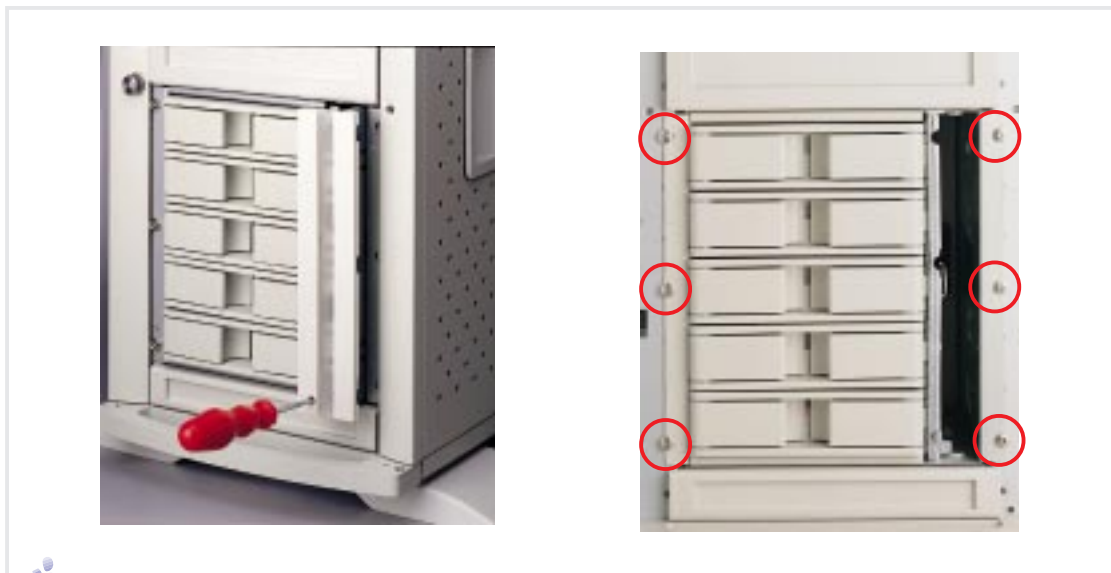

### Hot-Swap Bay

To remove the hot-swap bay, release the front cooling fans first by pressing the eject mechanism with a small screwdriver. Remove the six retaining screws as circled above and then the entire hot-swap bay can be slid out of the chassis.

# IV. Hardware Setup

## • 4-10. Front Cooling Fans

The front cooling fan module consists of a control board, a hard disk drive LED status board, and two cooling fans. The message LED board mounted in the front of the cooling fan module consists of five sets of LEDs to represent the status of up to five hard disk drives. Each set has three LEDs which can show the power, activity, and status of each hard disk drive.

The front cooling fans' main purpose is to cool the hard disk drives. These fans can be removed by using a small screw driver to push the eject mechanism in the fan module. The eject mechanism is behind a small hole as circled below. There are two individual 2 1/4 inch (6cm) fans secured by four screws on each fan. The ASMA software will report an error message when any of these two fans malfunctions.

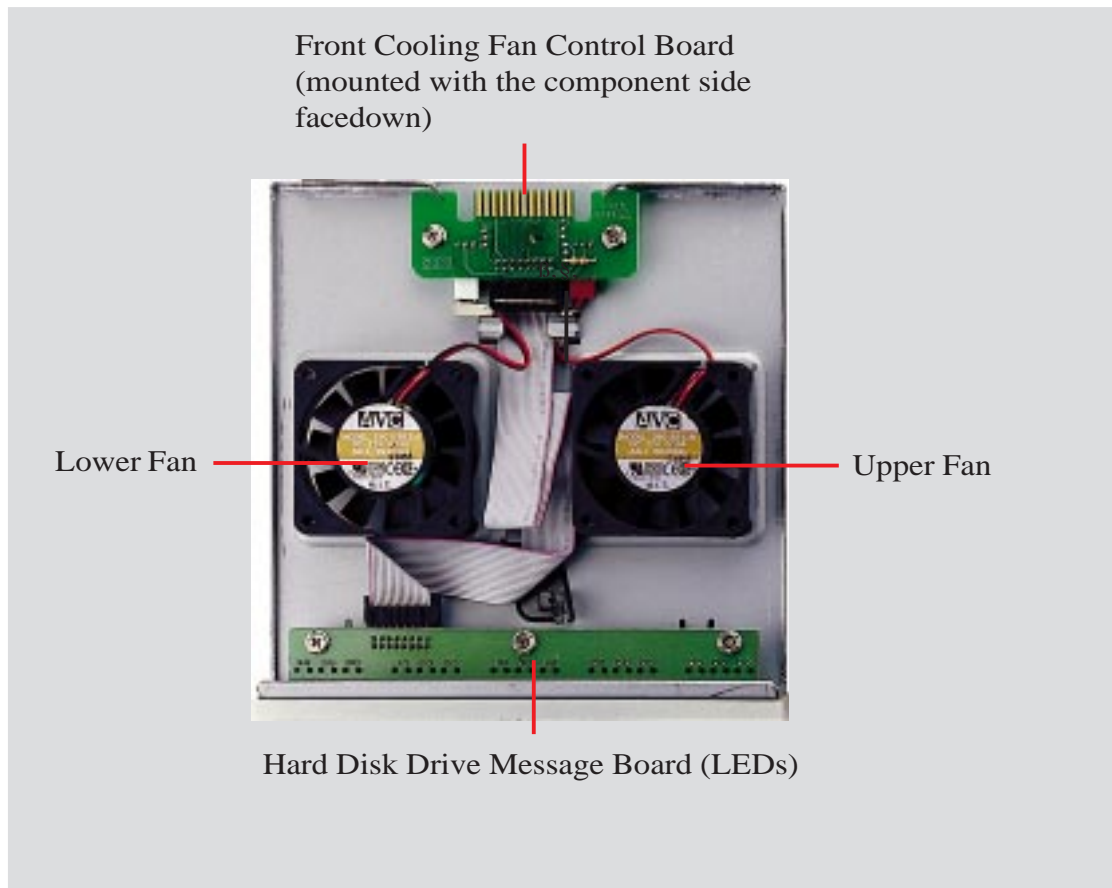

### IMPORTANT

Usually, the rotation of the fan sends air toward the manufacturer's label on the center of the fan.

# IV. Hardware Setup

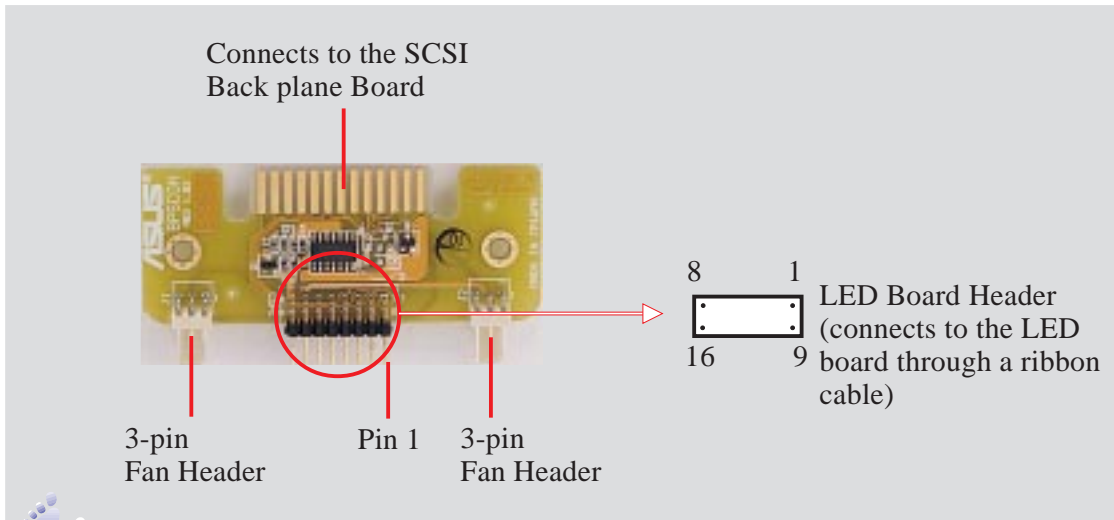

## Front Cooling Fan Control Board

A cable connects the front cooling fan control board and the hard disk drive message board. Orient the red markings on each end of the cable to pin 1.

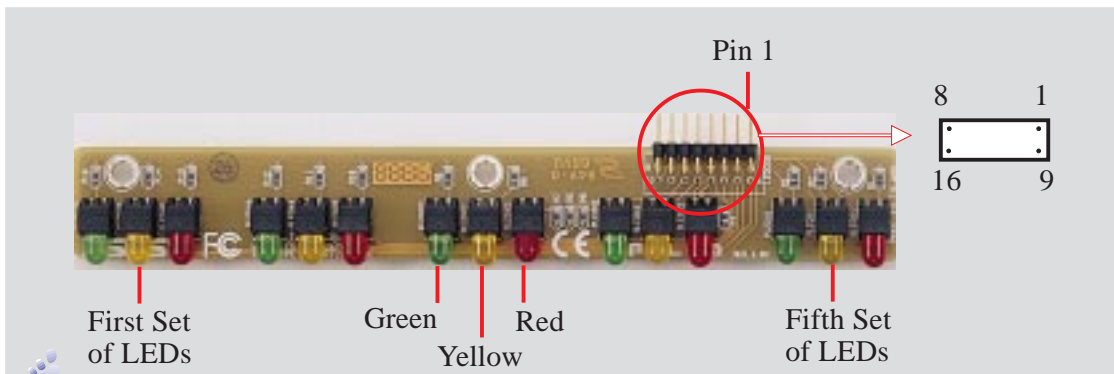

## Hard Disk Drive Message Board

Orient the red markings on the other end of the cable to pin 1. If the fifth set of LEDs fails, it can be indicating a faulty front cooling fan control board condition. Remove the control board and send it back to your dealer.

### Message LED Description

- Green: Power LED
- Yellow: Hard Disk Access LED
- Red: Hard Disk Status LED

Power LED	Status LED	Description
off	off	Power subsystem OK and ready for hard drive insertion
on	off	Hard disk drive is ready for operation
on	on	Hard disk drive failure (*)
on	fast flash	RAID is rebuilding (*)
on	slow flash	Hot-spare hard disk drive ready (*)
fast flash	on	Hard disk drive failure/short circuits
fast flash	fast flash	Fan failure

\* Must be provided by RAID controller's SAF-TE function.

# IV. Hardware Setup

## • 4-11. SCSI Backplane

The SCSI backplane of this server is comprised of one SCSI board (DA-BP5) with Ultra2 SCSI connectors, power inputs, and SCSI ID dip switches. This configuration allows Ultra2 SCSI SCA hard disk drives to be docked into the server. The SCSI board (DA-BP5) does not have auto termination, therefore the included terminator block must be used on the end connector.

### SCSI Backplane Front Side

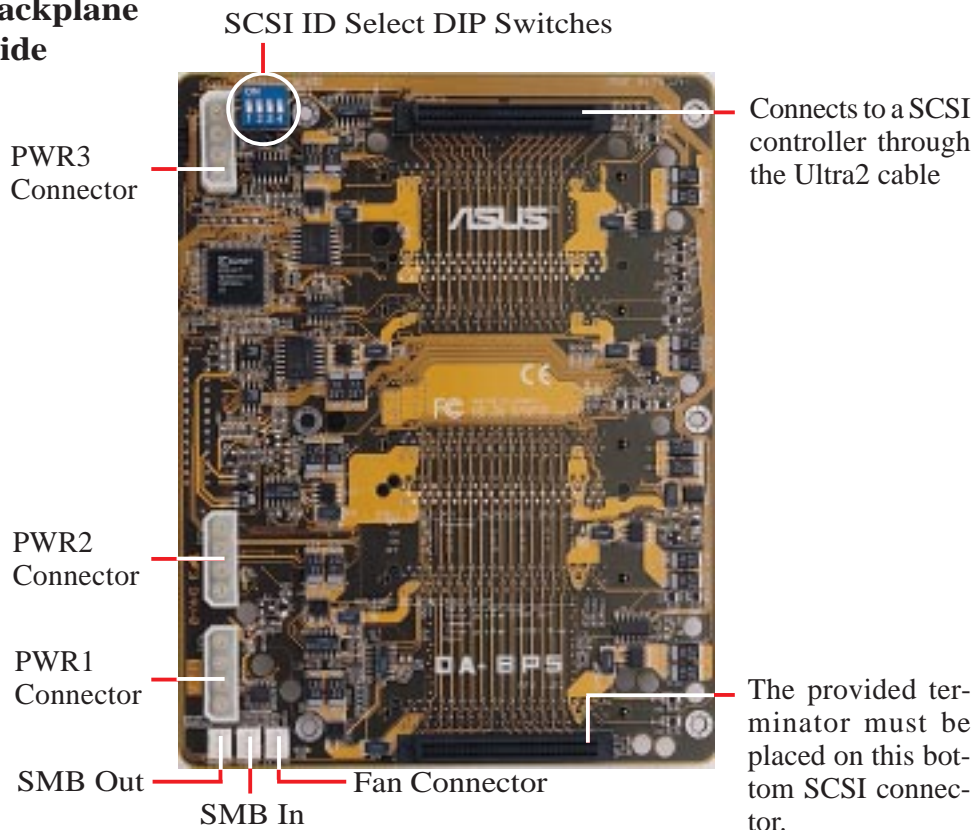

### SCSI Backplane Back Side

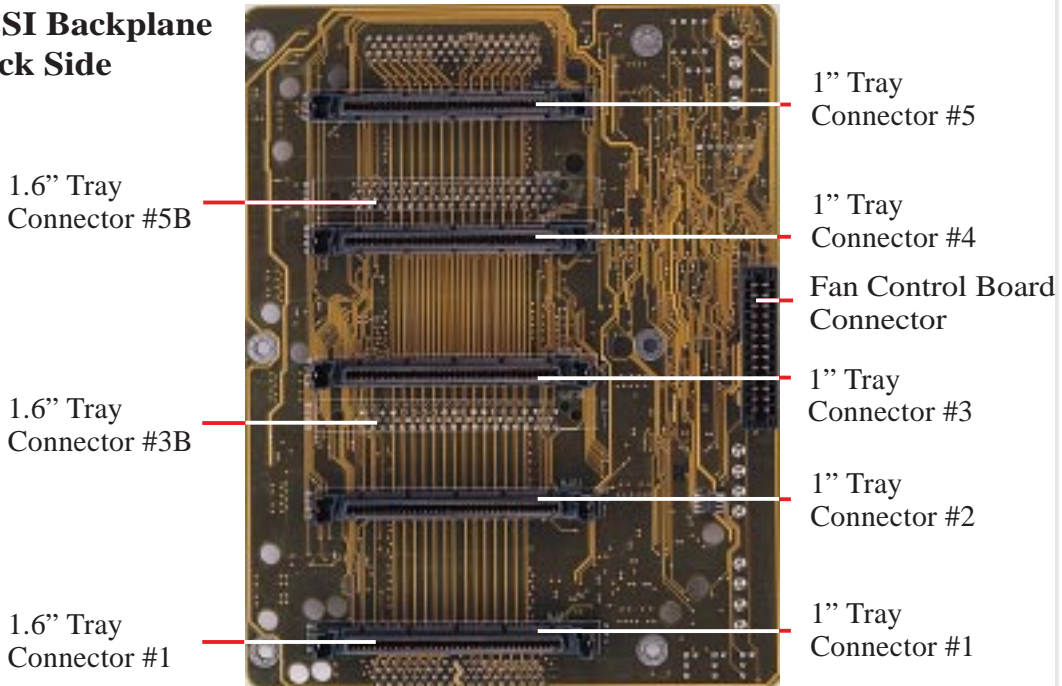



# IV. Hardware Setup

## • 4-12. SCSI ID Setting

SCSI ID settings are made through DIP switches located on the SCSI board. The SCSI board has four dip switches to set the hard drive's power-ON delay and SCSI ID.

### SCSI ID Setting

IDSEL1	IDSEL0	Slot1	Slot2	Slot3A/3B	Slot4	Slot5A/5B
off	off	Reserved				
on	on	15	12	11	8	3
on	off	14	9	6	4	1
(*) off	on	13	10	5	2	0

(\*) Default

### Hard Disk Drive Power On Delay

RMT_START	DLY_START	Description
off	off	Motor (spin) up when powering on
on	off	Motor (spin) up after START UNIT command
(*) off	on	Motor (spin) up after 12xSCSI ID ms
on	on	Reserved

(\*) Default



### SCSI ID Dip Switches



	IDSEL1	IDSEL0	Slot1	Slot2	Slot3A	Slot4	Slot5A
	off	off	Resv.				
	on	on	15	12	11	8	3
	on	off	14	9	6	4	1
	off	on	13	10	5	2	0

# IV. Hardware Setup

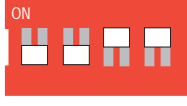
## SCSI ID Dip Switches (Cont')

	IDSEL1	IDSEL0	Slot1	Slot3B	Slot5B
 IDSEL 1=off IDSEL 0=off	off	off	Resv.		
 IDSEL 1=on IDSEL 0=on	on	on	15	11	3
 IDSEL 1=on IDSEL 0=off	on	off	14	6	1
 IDSEL 1=off IDSEL 0=on	off	on	13	5	0

### NOTE



All SCSI devices must have a SCSI identification number that is not in use by any other SCSI device. SCSI devices vary in how they set the ID number. Refer to the product manual for any additional devices that you may install for details on how to set its ID number.

## • 4-13. Expansion Card Guide

The chassis provides an adjustable expansion card guide to help hold expansion cards in their slots.

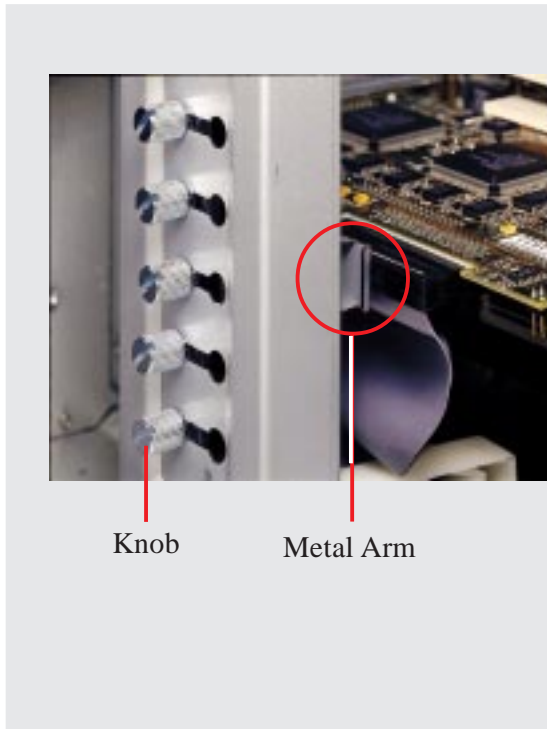

### Securing Expansion Card Guide

The expansion card guide is mounted by four screws on the top and bottom edge of the chassis. There are 18 knobs on the stabilizer. Turn the knob over the appropriate expansion card counterclockwise to extend the metal arm under each knob. Keep turning until the arm is firmly pressed against the expansion card. Turn the knob clockwise to retract the metal arm.

## IV. Hardware Setup

### • 4-14. SCSI Termination

Terminating the SCSI bus “chain” is necessary for SCSI devices to work properly. Ultra2 devices do not have termination jumpers and must be terminated using a terminator on the SCSI cable which means you cannot connect a device on the last connector.

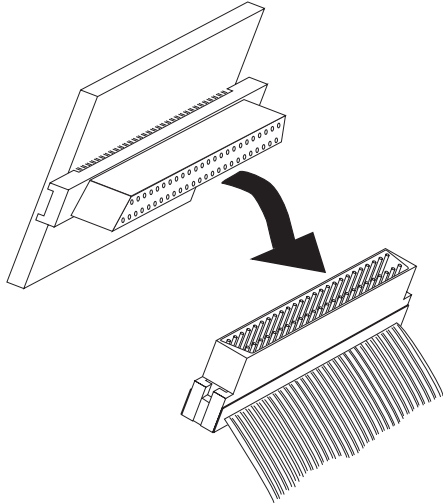

Female Terminator for SCSI cable

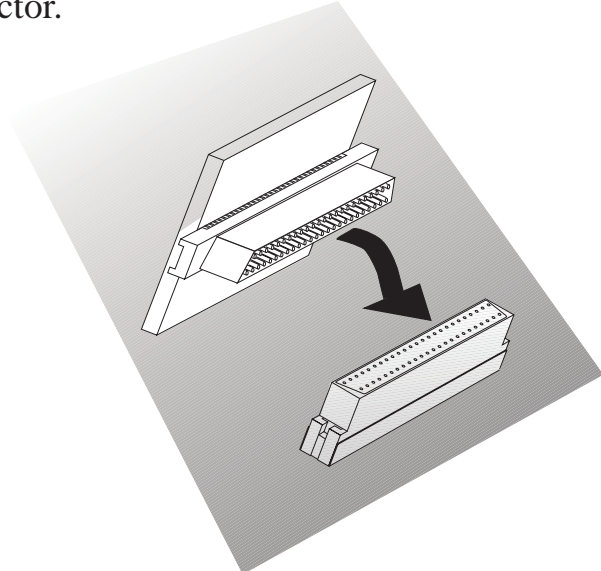

Male Terminator for SCSI Board

### • 4-15. Power Supply

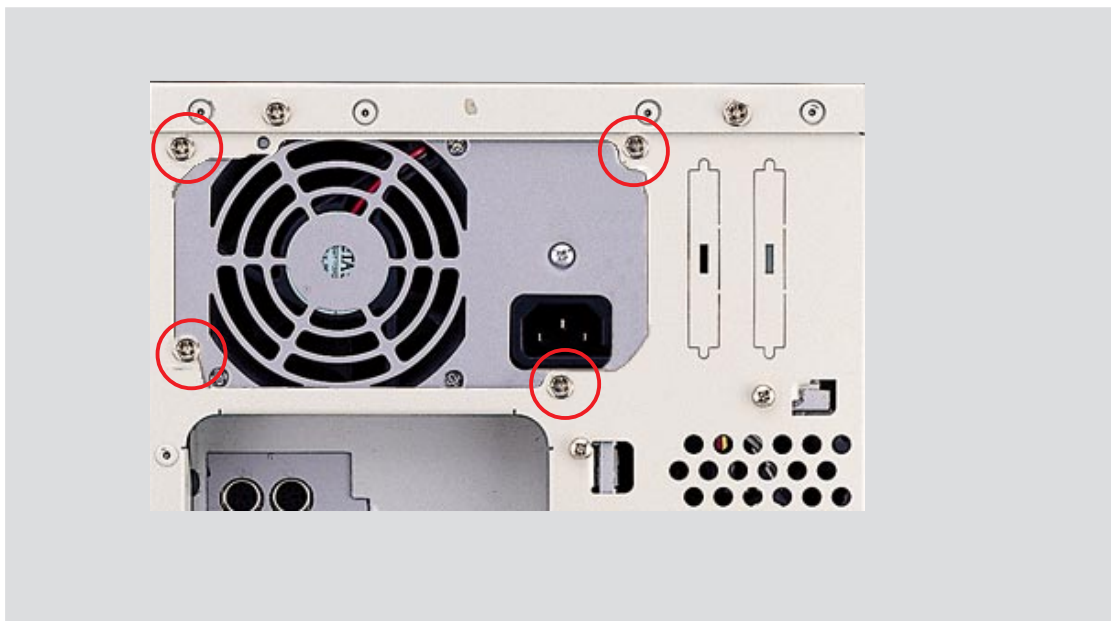

#### Power Supply Mounting

Mounting and unmounting the power supply must be done from the inside. Four screws are used to secure the power supply to the chassis back side.

# IV. Hardware Setup

## Power Supply Information

### Output Voltage Regulation, Ripple, and Noise

Output Voltage Limits (Vdc)				Ripple/Noise
Output	Min	Nom	Max	Maximum
1	3.17V	3.30V	3.46V	50mV <sub>p-p</sub>
2	4.80V	5.00V	5.25V	50mV <sub>p-p</sub>
3	11.40V	12.00V	12.60V	120mV <sub>p-p</sub>
4	-4.50V	-5.00V	-5.50V	120mV <sub>p-p</sub>
5	-10.92V	-12.00V	-13.20V	120mV <sub>p-p</sub>
6	4.75V	5.00V	5.25V	50mV <sub>p-p</sub>

### Output Current Capacity

Output	Nom (Vdc)	Max (A)	Min (A)
1	3.3V	*20.0	1.0
2	5.0V	*45.0	2.0
3	12.0V	12.0	0.5
4	-5.0V	0.5	0.0
5	-12.0V	0.5	0.0

\* Total output power for 3.3V and 5V combined shall be 210W

### Input Voltage

Range	Min (V)	Nom (V)	Max (V)
Range 1	90	120	137
Range 2	180	230	265

### Safety

The power system meets all applicable clauses for UL 1950 2nd edition without D3 deviations. The power system passes all tests for CUL and TUV safety.

### EMI

The power system, operating with resistive load, meets FCC class B and CISPR 22 class B conducted limits.

## IV. Hardware Setup

### • 4-16. Power Supply Requirement

Power Supply Requirement Calculation Table

Item	Volts	Amp	x	Qty.	=	Total Amp	Watts (5V)	Watts (12V)
Total Motherboard Power							209.55	3.6
Hard Drive	5.0V	1.3	x		=			
	12V	1.5	x		=			
CD-ROM	5.0V		x		=			
	12V		x		=			
Tape Drive	5.0V		x		=			
	12V		x		=			
Floppy Drive	5.0V		x		=			
	12V		x		=			
System Fans	5.0V		x		=			
	12V	0.3	x		=	0.6		7.2
Other	3.3V		x		=			
	5.0V		x		=			
	12V		x		=			
<b>Total Power</b>								

---

(This page was intentionally left blank)

# V. Appendix

## i. SCSI Cable Limits

SCSI cables have a limit to the length that it may have. Exceeding the length may cause problems mounting or using any one of the SCSI devices.

### CAUTION



Exceeding the SCSI cable limits may cause unreliable data transfers even if all the devices are mounted properly.

<u>Cable Limits</u>	<u>Max Data Transfer Rates</u>	<u>Max Devices</u>
1) 12m (29.4ft)	Ultra2-SCSI (68 pin 80MB/Sec)	15
2) 3m - 1.5m	Wide Ultra-SCSI (68 pin 40MB/Sec)	4 - 8
3) 3m (9.8ft)	Wide-SCSI (68 pin 20MB/Sec)	15
4) 3m - 1.5m	Narrow Ultra-SCSI (50 pin 20MB/Sec)	4 - 7
5) 3m (9.8ft)	Narrow Fast-SCSI (50 pin 10MB/Sec)	7

### IMPORTANT



- Narrow refers to 50 pin and Wide refers to 68 pin. Don't get confused by the width of the connector or cable.
- The SCSI ID for devices on one connector cannot be the same as the SCSI ID for devices on the other connectors. None of the devices on any connector can use ID7, which is reserved for the SCSI controller.
- A maximum of **15** devices may be connected to the motherboard (three connectors) at one time.

### NOTE



- A total of **15** "Ultra2-SCSI" devices (ID0-ID15) may be connected to the 68-pin Ultra2 connector on the motherboard.
- If connecting Fast/Ultra devices with Ultra2 devices on the Ultra2 connector, the entire SCSI bus will be limited to the Ultra SCSI conditions listed above. Mixing SCSI devices is highly not recommended.
- A total of **8** "Wide Ultra-SCSI" devices (ID0-ID15) may be connected to the 68-pin Wide connector if using a 1.5m (4.9ft) cable, but only **4** "Wide Ultra-SCSI" devices if using a 3m (9.89ft) cable. Ultra-SCSI technology is unstable over long lengths, therefore stability will depend on they quality of your cable and devices.
- A total of **15** "Wide-SCSI" devices (ID0-ID15) may be connected to the 68-pin Wide connector.
- A total of **7** "Narrow Ultra-SCSI" devices (ID0-ID6) may be connected to the 50-pin Narrow connector when using 1.5m (4.9ft) cable but only 4 devices when using 3m (9.8ft) cable. Ultra-SCSI technology is unstable over long lengths, therefore stability will depend on the quality of your cable and devices.
- A total of **7** "Narrow Fast SCSI" devices (ID0-ID7) may be connected to the 50-pin Narrow connector.

# V. Appendix

---

## ii. Glossary

### **Byte (Binary Term)**

One byte is a group of eight contiguous bits. A byte is used to represent a single alphanumeric character, punctuation mark, or other symbol.

### **CHKDSK (Check Disk)**

An MS-DOS command that gives you information such as disk space, files, and directories on your hard disk drive.

### **COM Port**

COM is a logical device name used to designate the computer serial ports. Pointing devices, modems, and infrared modules can be connected to COM ports. Each COM port is configured to use a different IRQ and address assignment.

### **CPU (Central Processing Unit)**

The CPU, sometimes called “Processor,” actually functions as the “brain” of the computer. It interprets and executes program commands and processes all the data stored in memory. Currently, there are socket 7, slot 1, and slot 2 CPUs. Intel Pentium Processors fit on socket 7, Intel Pentium II fit on slot 1, and Intel Xeon fit on slot 2.

### **FDISK (Fixed Disk Setup Program)**

An MS-DOS program used to partition the hard disk drive. FDISK is required to setup a new non-RAID hard disk drive before formatting and installing an operating system.

### **IDE (Integrated Drive Electronics)**

IDE devices integrate the drive control circuitry directly on the drive itself, eliminating the need for a separate adapter card (in the case for SCSI devices). UltraDMA/33 IDE devices can achieve up to 33MB/Sec transfer.

### **LPT Port (Line Printer Port)**

Logical device name reserved by DOS for computer parallel ports. Each LPT port is configured to use a different IRQ and address assignment.

### **PCI Bus (Peripheral Component Interconnect Local Bus)**

PCI bus is a specification that defines a 32-bit data bus interface. PCI is a standard widely used by expansion card manufacturers.



# V. Appendix

---

## **Peripherals**

Peripherals are components on the outside of the computer such as a monitor, printer, keyboard, or mouse. Peripherals are attached to the computer via I/O ports. Peripheral devices allow your computer to perform an almost limitless variety of specialized tasks.

## **POST (Power On Self Test)**

When you turn on the computer, it will first run through the POST, a series of software-controlled diagnostic tests. The POST checks system memory, the motherboard circuitry, the display, the keyboard, the diskette drive, CPU, and other I/O devices.

## **PS/2 Port**

PS/2 ports are based on IBM's Micro Channel Architecture. This type of architecture transfers data through a 16-bit or 32-bit bus. A PS/2 mouse and/or keyboard may be used on ATX motherboards.

## **RAID (Redundant Array of Inexpensive Disks)**

RAID can be set up to provide mirroring (for fault tolerance), parity (for data guarding), or striping (for data distribution over several drives for increased performance). A RAID card is required to setup a RAID system.

## **RAM (Random Access Memory)**

There are several different types of RAM such as DRAM (Dynamic RAM), EDO DRAM (Extended Data Out DRAM), SDRAM (Synchronous DRAM).

## **ROM (Read Only Memory)**

ROM is nonvolatile memory used to store permanent programs (called firmware) used in certain computer components. Flash ROM (or EEPROM) can be reprogrammed with new programs (or BIOS).

## **SCSI (Small Computer System Interface)**

High speed parallel interface defined by the X3T9.2 committee of the American National Standards Institute (ANSI) for connecting many peripheral devices.

## **UPS (Uninterruptible Power Supply)**

A battery system that can provide power to an electronic device or computer when power fails in the building. A passive UPS only provides power. An active UPS provides power conditioning that offers protection against transient power conditions and short-term power outages.

---

(This page was intentionally left blank.)